



Features

- Temperature accuracy up to 0.1 °C (0.18 °F)
- Temperature measurement range -70 ... +180 °C (-94 ... +356 °F)
- Modbus RTU over RS-485
- Plug & play compatible with Indigo series of transmitters
- Traceable 2-point calibration certificate (calibration points at +20 and +70 °C (+68 and +158 °F))

Vaisala Temperature Probe TMP1 is designed for demanding temperature measurements in industrial applications such as pharmaceutical industry and calibration laboratories, where accuracy and robustness are essential.

Flexible Connectivity

The probe is plug and play compatible with Vaisala Indigo series of transmitters, or it can be used as a standalone digital Modbus RTU transmitter over RS-485 serial bus. For easy-to-use access to field calibration, device analytics, and configuration functionality, the probe can be connected to Vaisala Insight software (for Windows® 7, 8.1 and 10: see www.vaisala.com/insight).

Vaisala Indigo Product Family

Indigo transmitters offer a variety of connectivity options through analog signals or digital outputs, configurable relays, and wireless (WLAN)

configuration interface, providing a suitable solution for all industrial humidity measurements. The cable length between the probe and transmitter can be extended to up to 30 meters. For more information, see www.vaisala.com/indigo.

Relative Humidity Measurements in High Humidities

When the TMP1 probe is connected to a control system in parallel with HMP7 Relative Humidity and Temperature Probe, it is possible to have relative humidity measurement in actual process temperature while using probe heating in

the relative humidity probe. Probe heating helps to avoid condensation in situations where the dew point temperature of the process is close to the ambient temperature.

When the humidity probe is heated above dew point temperature, condensation can be avoided and the relative humidity in the actual process temperature can be back-calculated based on the true process temperature measurement received from TMP1.

Technical Data

Measurement Performance

Sensor	Pt100 RTD Class F0.1 IEC 60751
Measurement range	-70 ... +180 °C (-94 ... +356 °F)
Accuracy at +23 °C (+73.4 °F) ¹⁾	±0.1 °C (±0.18 °F)

1) Defined against calibration reference

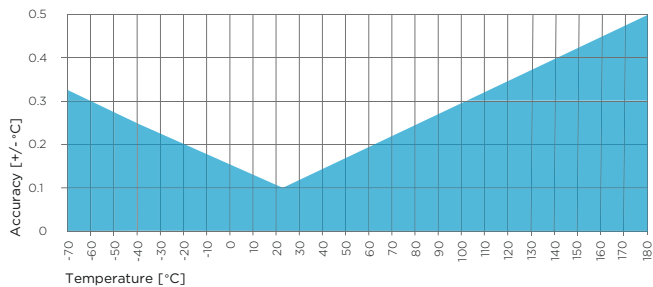

TMP1 Temperature Measurement Accuracy over Full Range (Including Non-Linearity and Repeatability)

SI Traceable Calibration

Uncertainty of temperature calibration ±0.1 °C (±0.18 °F) at +23 °C (+73.4 °F) ($k = 2$)

Operating Environment

Operating temperature range for probe body -40 ... +80 °C (-40 ... +176 °F)

Operating temperature range for probe head -70 ... +180 °C (-94 ... +356 °F)

Operating environment Suitable for outdoor use

IP rating IP66

Electromagnetic compatibility Complies with EMC standard EN61326-1, Industrial Environment

Inputs and Outputs

Operating voltage 15 ... 30 VDC

Current consumption 10 mA typical

Digital output RS-485, non-isolated

Default serial settings 19200 bps N 8 2

Protocols Modbus RTU

Output parameters Temperature, water vapor saturation pressure

Mechanical Specifications

Connector	M12/5
Weight	224 g (7.9 oz)

Materials

Probe	AISI316L
Probe body	AISI316L
Cable jacket	FEP

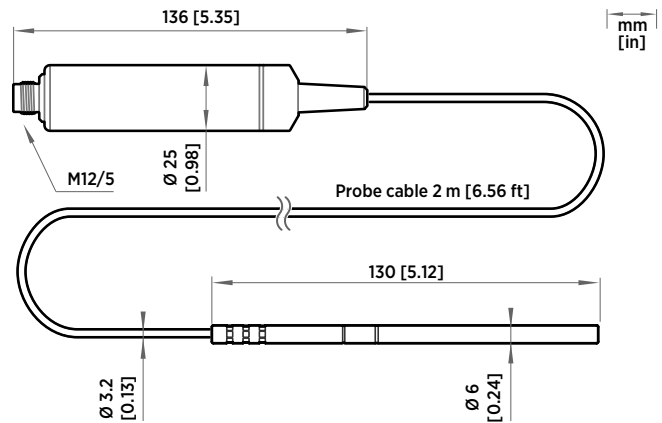

TMP1 Probe Dimensions



VAISALA

www.vaisala.com

Published by Vaisala | B211685EN-B © Vaisala 2018

All rights reserved. Any logos and/or product names are trademarks of Vaisala or its individual partners. Any reproduction, transfer, distribution or storage of information contained in this document is strictly prohibited. All specifications – technical included – are subject to change without notice.