

VAISALA

USER'S GUIDE

Vaisala Structural Humidity Measurement Kit SHM40



M211423EN-C

PUBLISHED BY

Vaisala Oyj
P.O. Box 26
FI-00421 Helsinki
Finland

Phone (int.): +358 9 8949 1
Fax: +358 9 8949 2227

Visit our Internet pages at www.vaisala.com.

© Vaisala 2015

No part of this manual may be reproduced in any form or by any means, electronic or mechanical (including photocopying), nor may its contents be communicated to a third party without prior written permission of the copyright holder.

The contents are subject to change without prior notice.

Local rules and regulations may vary and they shall take precedence over the information contained in this manual. Vaisala makes no representations on this manual's compliance with the local rules and regulations applicable at any given time, and hereby disclaims any and all responsibilities related thereto.

Please observe that this manual does not create any legally binding obligations for Vaisala towards the customer or end user. All legally binding commitments and agreements are included exclusively in the applicable supply contract or Conditions of Sale.

Table of Contents

CHAPTER 1	
GENERAL INFORMATION	5
About This Manual	5
Contents of This Manual	5
Version Information	6
Related Manuals	6
Documentation Conventions	6
Safety	7
ESD Protection	7
Recycling	8
Regulatory Compliances	8
Trademarks	8
Warranty	9
CHAPTER 2	
PRODUCT OVERVIEW	11
Introduction to SHM40 Kit	11
SHM40 Kit Contents	12
CHAPTER 3	
HUMIDITY MEASUREMENT IN CONCRETE	15
Humidity Measurements in a Borehole	15
Measurement Depth	16
Humidity Profile	16
Maximum Humidity Levels for Coating	18
Importance of Temperature Differences	19
Preparations for Measurement	20
Preparations for Solid Concrete	21
Preparations for Freshly Cast Concrete	22
Inserting the Probe and Sealing the Hole	24
Alternate Sealing Materials	27
Plastic Tubes	27
Rubber Plugs	27
Protective Covers	27
Performing the Measurement	28
Ending the Measurements	29
CHAPTER 4	
USING THE HM40 INDICATOR	31
HM40 Indicator	31
Batteries	32
Battery Life	33
Charging	33

Connecting the Probe	34
First Startup	35
Initial Settings	35
Quantities Explained	36
Screen Layout and Controls.....	37
Indicators	38
Numeric View	38
Statistics View	39
Graph View.....	39
Hold and Tag	40
Main Menu	42
Tagged Points	42
Graph Duration	43
Settings.....	43
Calibration	44
Help	44
Settings Submenu	45
Language.....	45
Units.....	45
Time & Date.....	46
Pressure	47
Reminder	47
Backlight.....	48
Battery	48
Power off	48
Navigation.....	49
Rounding	49
Factory Settings.....	49

CHAPTER 5

MAINTENANCE.....	51
Periodic Maintenance.....	51
Cleaning	51
Changing the Filter	52
Calibration	52
Calibrating the HMP40S Probe Using HMK15 Humidity Calibrator	53
Repair Maintenance.....	56

CHAPTER 6

TROUBLESHOOTING.....	57
Avoid Condensation and Rain	57
Problem Situations	58
Technical Support	59

CHAPTER 7

TECHNICAL DATA	61
Specifications	61
Spare Parts and Accessories	63
Dimensions in mm.....	64

APPENDIX A

List of Figures

Figure 1	Contents of the SHM40 Kit	12
Figure 2	Drying in One Direction	17
Figure 3	Drying in Two Directions.....	17
Figure 4	Measurement Error at 1 °C Temperature Difference	19
Figure 5	Pressing the Tube into the Hole	21
Figure 6	Preparing the Tube for Fresh Concrete.....	22
Figure 7	Plugged Tube in Fresh Concrete.....	23
Figure 8	Cracking the Concrete at the Bottom of the Tube	23
Figure 9	Locking the Cover in Place.....	24
Figure 10	Sealing the Tube with a Rubber Plug.....	25
Figure 11	Cable Folded in the Protective Cover.....	25
Figure 12	Recommended Setup During Stabilization.....	26
Figure 13	Performing the Measurement	28
Figure 14	HM40 Indicator for Structural Humidity Measurements.....	31
Figure 15	HMP40S Probe.....	32
Figure 16	Connecting the Probe	34
Figure 17	Screen Layout.....	37
Figure 18	Elements of the Graph View.....	39
Figure 19	Tagged Points in the Graph View.....	41
Figure 20	Changing the Filter	52
Figure 21	HM40S Dimensions	64

List of Tables

Table 1	Manual Revisions	6
Table 2	Related Manuals.....	6
Table 3	Wooden Floor Coverings	18
Table 4	Other Materials	18
Table 5	Quantities Output by HM40S.....	36
Table 6	Indicators on the HM40 Display.....	38
Table 7	Some Problem Situations and Their Remedies	58
Table 8	HMP40S Probe.....	61
Table 9	HM40 Indicator	62
Table 10	Spare Parts and Accessories	63

CHAPTER 1

GENERAL INFORMATION

This chapter provides general notes for the manual and the SHM40 kit.

About This Manual

This manual provides information for operating, and maintaining the Vaisala Structural Humidity Measurement Kit SHM40. The manual also instructs in performing structural humidity measurements using the borehole method.

Contents of This Manual

This manual consists of the following chapters:

- Chapter 1, General Information, provides general notes for the manual and the SHM40 kit.
- Chapter 2, Product Overview, introduces the features, advantages, and the product nomenclature.
- Chapter 3, Humidity Measurement in Concrete, describes the borehole method of concrete humidity measurement.
- Chapter 4, Using the HM40 Indicator, introduces the functions of the HM40 indicator and the HMP40S probe.
- Chapter 5, Maintenance, provides information that is needed in basic maintenance of the SHM40 kit.
- Chapter 6, Troubleshooting, describes common problems, their probable causes and remedies, and provides contact information for technical support.
- Chapter 7, Technical Data, provides the technical data of the SHM40 kit.
- Appendix A, Humidity Report Form, contains an example report form that can be used to record humidity measurement results.

Version Information

Table 1 Manual Revisions

Manual Code	Description
M211423EN-C	October 2015. This manual. HM40 indicator software version updated to 1.5 with new calibration reminder and automatic power off functionalities. RH measurement accuracy specification updated. 2-point calibration reference limit information added. New carrying case model added. Disclaimer information updated.
M211423EN-B	April 2012. Previous version. Moved measurement procedures to chapter 3. Updated safety precautions, calibration screenshots, and accessories list. Added an example humidity report sheet.
M211423EN-A	First version.

Related Manuals

Table 2 Related Manuals

Manual Code	Manual Name
M211088EN	HM40 Series User's Guide
M211087EN	HM40 Quick Guide
M210185EN	HMK15 User's Guide

Documentation Conventions

Throughout the manual, important safety considerations are highlighted as follows:

WARNING

Warning alerts you to a serious hazard. If you do not read and follow instructions very carefully at this point, there is a risk of injury or even death.

CAUTION

Caution warns you of a potential hazard. If you do not read and follow instructions carefully at this point, the product could be damaged or important data could be lost.

NOTE

Note highlights important information on using the product.

Safety

The SHM40 kit delivered to you has been tested approved as shipped from the factory. Note the following precautions:

WARNING

When drilling holes in concrete, wear respiratory protection to avoid breathing concrete dust. If you are drilling through a floor coating, note that the dust may also contain hazardous materials such as lead, asbestos fibers, or crystalline silica. When cleaning the hole, avoid blowing dust away from the hole – use a vacuum cleaner instead.

WARNING

Contact with fresh (unhardened) concrete may cause irritation or burns to the skin and eyes. Wear adequate protection and observe safe workplace practices.

CAUTION

Do not modify the unit. Improper modification can damage the product or lead to malfunction.

ESD Protection

Electrostatic Discharge (ESD) can cause immediate or latent damage to electronic circuits. Vaisala products are adequately protected against ESD for their intended use. It is possible to damage the product, however, by delivering electrostatic discharges when touching, removing, or inserting any objects inside the equipment housing.

To make sure you are not delivering high static voltages yourself, avoid touching exposed contacts on the probe or the meter.

Recycling



Recycle all applicable material.



Dispose of batteries and the unit according to statutory regulations. Do not dispose of with regular household refuse.

Regulatory Compliances

The Vaisala Structural Humidity Measurement Kit SHM40 is in conformity with the provisions of the following EU directive(s):

- EMC-Directive

Conformity is shown by compliance with the following standards:

- EN 61326-1: Electrical equipment for measurement, control, and laboratory use – EMC requirements – for portable equipment.
- EN 550022: Information technology equipment – Radio disturbance characteristics – Limits and methods of measurement.



Trademarks

HUMICAP® is a registered trademark of Vaisala Oyj.

Warranty

Visit our Internet pages for more information and our standard warranty terms and conditions: www.vaisala.com/warranty.

Please observe that any such warranty may not be valid in case of damage due to normal wear and tear, exceptional operating conditions, negligent handling or installation, or unauthorized modifications. Please see the applicable supply contract or Conditions of Sale for details of the warranty for each product.

This page intentionally left blank.

CHAPTER 2

PRODUCT OVERVIEW

This chapter introduces the features, advantages, and the product nomenclature.

Introduction to SHM40 Kit

Vaisala Structural Humidity Measurement Kit SHM40 is a practical tool for humidity measurement of concrete and other structures. The kit has been designed for use with the borehole method.

Main features:

- HM40 indicator
 - HM40 indicator with connection adapter for HMP40S probes.
 - Large graphical display with graphs for selected quantity and temperature.
 - Outputs a wide range of quantities: RH, Td, Tw, a, x, h, T. See section Quantities Explained on page 36.
 - Powered by standard AA size batteries (2 pcs).
 - Belt clip.
- Interchangeable HMP40S humidity and temperature probe
 - HMP110 probe and cable with integrated rubber plug.
 - Can be calibrated by a Vaisala Service Center or user calibrated using the HMK15 humidity calibrator, for example.
- Various accessories for ensuring accurate humidity measurement using the borehole method.
- Durable weatherproof case.
- Conforms to ASTM standard F2170.

NOTE

The HM40 indicator and HMP40S probe are also sold separately as the HM40S.

SHM40 Kit Contents

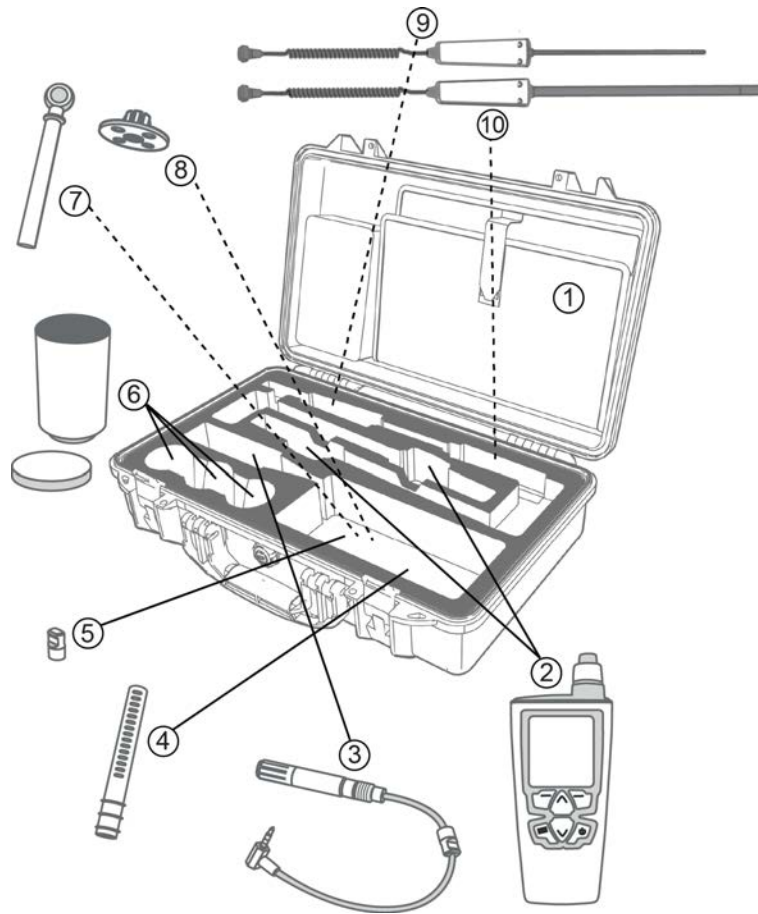

1508-113

Figure 1 Contents of the SHM40 Kit

Standard contents:

- 1 = Pocket for documents and accessories
- 2 = HM40 indicator with quick connection adapter (1 pc, HM40SINDI)
- 3 = HMP40S humidity and temperature probe (1 pc, HMP40S)
- 4 = Plastic tubes: Ø 17.4 mm, length 120 mm (12 pcs, 19266HM)
- 5 = Rubber plugs: Ø 13 mm, length 21 mm (12 pcs, 233976)
- 6 = Protective covers with lid: Ø 64 mm, length 101 mm (3 pcs, 19268HM)

Optional items not included with the standard kit:

- 7 = Long rubber plugs for fresh concrete (12 pcs, 26530HM)
- 8 = Plastic flanges for fresh concrete (12 pcs, 26529HM)
- 9 = HM42 probe for tight spaces (HM42PROBE)
- 10 = HM46 stainless steel robust probe (HM46PROBE)

You can order standard items and optional accessories from Vaisala. For the full list of accessories, see section Spare Parts and Accessories on page 63.

NOTE

Vaisala recommends using multiple HMP40S probes so that they can be inserted in all measurement points and left to equalize concurrently.

This page intentionally left blank.

CHAPTER 3

HUMIDITY MEASUREMENT IN CONCRETE

This chapter describes the borehole method of concrete humidity measurement.

Humidity Measurements in a Borehole

SHM40 kit is designed for measuring humidity in concrete using the **borehole method**. In the borehole method, a hole is drilled to a suitable depth in the concrete structure to be measured. After the drilling, the hole is cleaned and covered, and air humidity in the hole is allowed to equalize with the humidity in the concrete. The airspace humidity will reach humidity equilibrium with the concrete in about three days. After this, the humidity measurement is made.

For successful humidity measurement using the borehole method and the SHM40 kit, the following points are vital when preparing the hole:

- The hole must be \varnothing 16 mm and reach to proper depth. See section Measurement Depth on page 16.
- After drilling, the hole must be cleaned from the drilling debris.
- The hole must be allowed to cool down from the drilling, and the humidity in the concrete must be allowed to equalize with the air in the hole.
- The hole must be sealed during the equalization time. The plastic tube and rubber plug in the SHM40 kit are used for this purpose. Ideally, the probe should be inside the plastic tube during this time.

NOTE

For reliable results, it is recommended to have several measurement points.

Measurement Depth

The borehole must reach deep enough into the concrete structure to provide a representative humidity condition. The correct depth of the borehole is affected by the drying conditions of the concrete structure:

- When drying occurs from one side only, the measurement depth (d) is 40 % of the depth of a slab. See Figure 2 on page 17.
- For a concrete slab that is exposed to air on both sides, the minimum depth of measurement (d) is 20 % of the depth of the slab. See Figure 3 on page 17.

The minimum measurement depth using standard SHM40 accessories is 30 mm, maximum is 90 mm.

Humidity Profile

The humidity profile of the slab depends on the drying conditions of the concrete: whether the concrete dries in one or in two directions. In concrete slabs that dry in two directions, the humidity is highest in the middle. If a floor coating is applied, the humidity spreads evenly throughout the slab until it corresponds to readings measured at the depth of approximately 20% of the slab.

In concrete slabs that dry in one direction only, the humidity is highest at the bottom. If a floor coating is applied, the humidity spreads evenly throughout the slab until it corresponds to readings measured at the depth of approximately 40% of the slab.

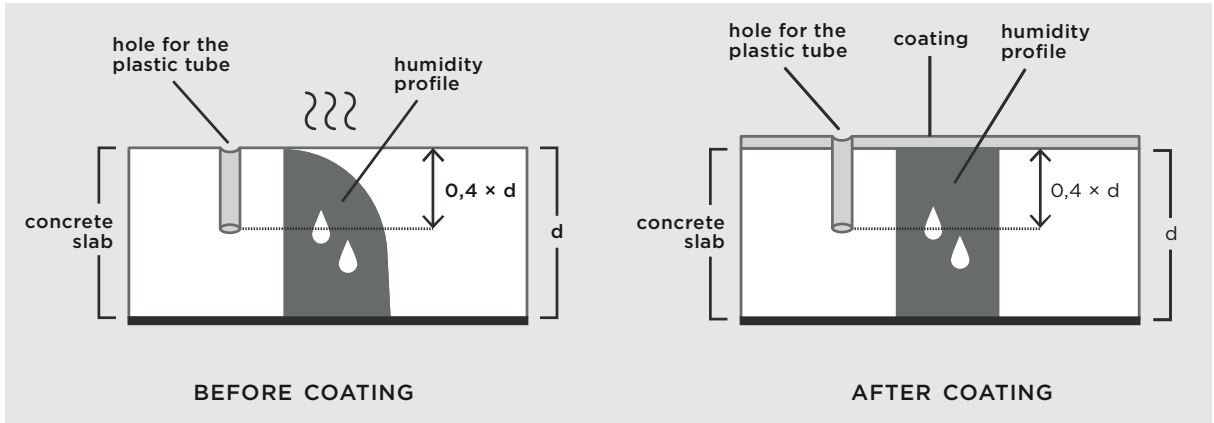

1111-093

Figure 2 Drying in One Direction

In concrete slabs drying in two directions, the humidity is highest in the middle of the slab. After coating, the slab is driest on the uncoated side.

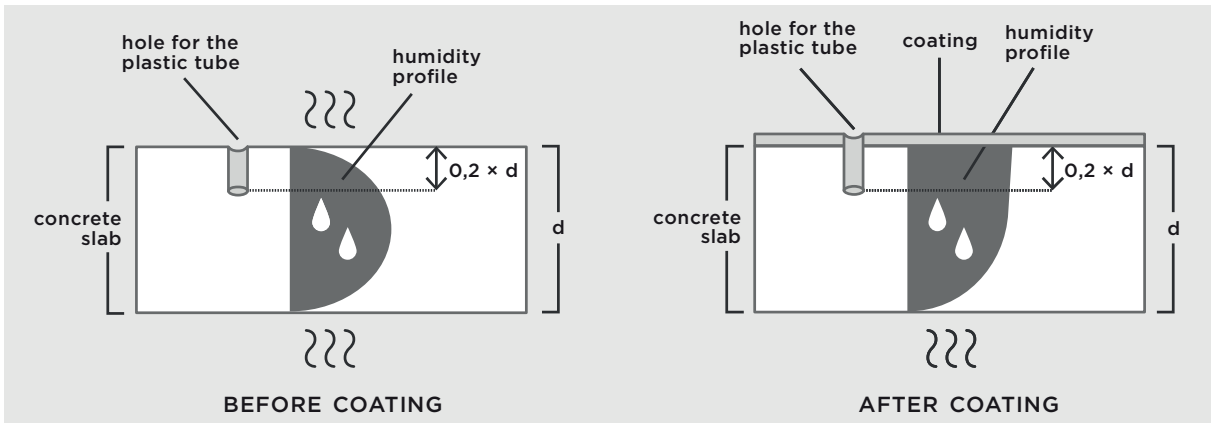

1111-094

Figure 3 Drying in Two Directions

Maximum Humidity Levels for Coating

SisäRYL 2000 Code of Building Practice (RT 14-10668, 2000, ISBN 951-682-506-0) recommends the following maximum humidity levels (at +20 °C) for coating of various materials:

Table 3 Wooden Floor Coverings

Maximum RH (%)	Coating
60*	Wooden parquet boards without moisture barrier (plastic film) between wood and concrete.
80*	Inlaid wooden floor coverings. Floating wooden floor coverings with moisture barrier (plastic film) between wood and concrete.

*SisäRYL 2000 Code of Building practice, RT 14-10668, 2000, ISBN 951-682-506-0, page 332.

Table 4 Other Materials

Maximum RH (%)	Coating
85*	Plastic floor coverings with fiber felt base or cellular plastic base Rubber floor coverings Cork tiles with moisture barrier (plastic film) Textile floor coverings with rubber, PVC or latex base Natural fiber textile floor coverings without base
90*	Plastic tiles Plastic floor coverings without felt or cellular plastic base Linoleum (Cork) Man-made fiber textile floor coverings without base structure
97	Epoxy mass Acrylic mass Polyester plastic mass

*SisäRYL 2000 Code of Building practice, RT 14-10668, 2000, ISBN 951-682-506-0, page 318.

Importance of Temperature Differences

CAUTION

Temperature of the probe and the concrete must be equal before starting the measurement!

In humidity measurement, and especially in calibration, it is essential that the temperature of the probe and the measured environment is the same. Even a small difference in temperature between the measured environment and the probe causes an error. As the curve below shows, if the temperature is +20 °C and the relative humidity 100 %RH, a difference of ± 1 °C between the measured object and the probe causes an error of ± 6 %RH. When the humidity is 90 %RH, the corresponding error is ± 5.4 %RH.

A temperature difference of a few degrees can also cause water to condense on the sensor surface. HUMICAP[®] sensor starts to function normally as soon as the water has evaporated. If the condensed water is contaminated, the life span of the probe may shorten and the probe may require adjustment.

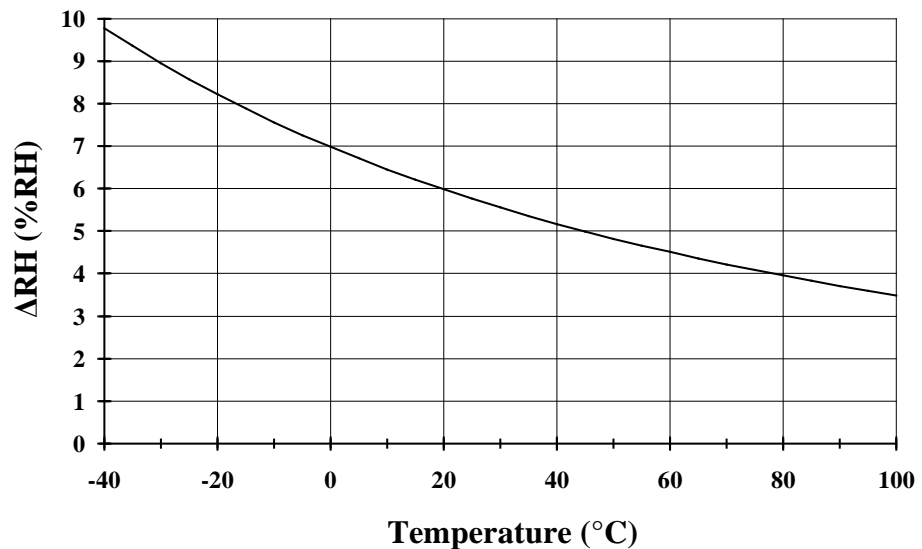

1111-102

Figure 4 Measurement Error at 1 °C Temperature Difference

Figure 4 above shows the measurement error at 100 %RH at temperatures ranging from -40 to 100 °C, when the difference between the ambient and sensor temperature is 1 °C.

Preparations for Measurement

Before you can measure the humidity of concrete using the borehole method, you must prepare the borehole and wait for humidity to stabilize. The preparations can be started on a freshly cast concrete if desired.

CAUTION

Before starting, read section Measurement Depth on page 16. Appropriate depth of the borehole is critical for accuracy.

NOTE

For best results, insert the probe to the plastic tube immediately after you are finished preparing the borehole, and leave it to stabilize for three days.

NOTE

Make sure that the tube and the probe are not colder than the concrete when inserting them: this might cause condensation on the probe and the readings can be incorrect.

Preparations for Solid Concrete

Prepare the boreholes at least three (3) days before the measurements, so that the humidity inside the plastic tube has time to reach equilibrium with the humidity in the concrete. Each borehole must be completely prepared and sealed during stabilization, ideally with the probe remaining inside the tube. Follow the instructions below.

1. Three days before the measurements, drill at least two holes with diameter of \varnothing 16 mm and appropriate depth. See section Measurement Depth on page 16.
2. Clean the hole thoroughly using a vacuum cleaner.
3. Press a plastic tube (19266HM) into the hole. If you need something to press it with, use the lid of the protective cover. See Figure 5 below.

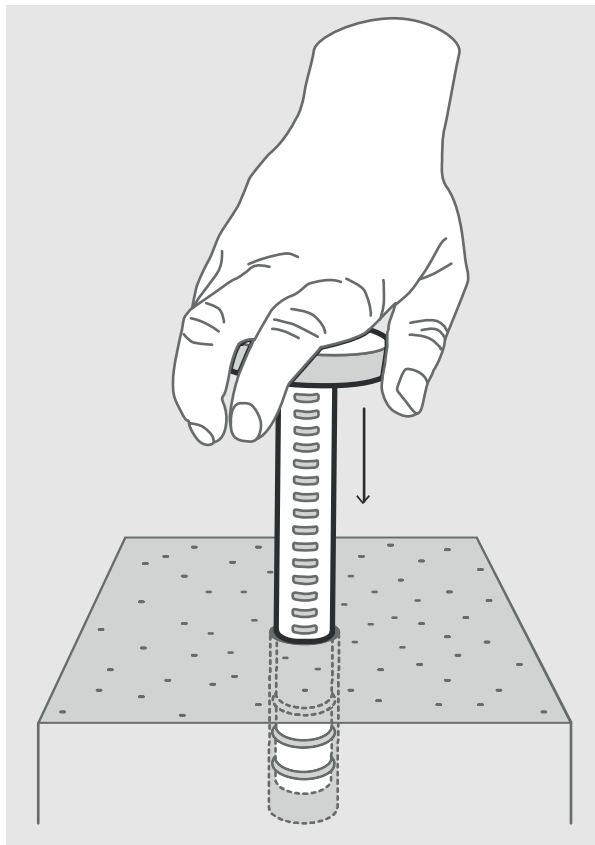

1111-095

Figure 5 Pressing the Tube into the Hole

4. Now you have a clean borehole that reaches to the correct depth, and a plastic tube in it. For best results, you can also seal the crack around the tube and concrete with a suitable material.

Continue from section Inserting the Probe and Sealing the Hole on page 24.

Preparations for Freshly Cast Concrete

Preparing the measurement in freshly cast concrete has the advantage that no drilling of the concrete is needed, and tubes are easy and fast to install. You can do the preparations without any danger to floor heating elements or water tubing that may be embedded in the concrete.

After the concrete is cast and you have decided where to measure, prepare each measurement point as follows:

1. Place the flange (26529HM) around the tube and make sure it clips on to one of the grooves on the surface of the tube. The distance of the flange from the bottom of the tube determines how deep the tube will be inserted in the concrete (dimension X in Figure 6 below).
2. Push the long rubber plug (26530HM) inside the tube to prevent the fresh concrete from blocking it.

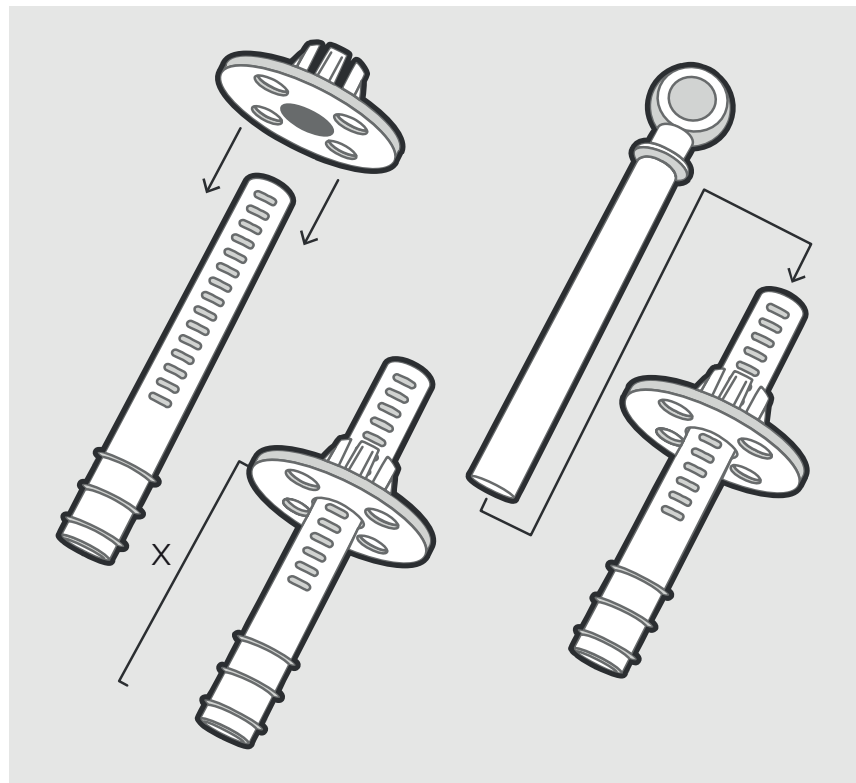

1111-090

Figure 6 Preparing the Tube for Fresh Concrete

3. Push the combined tube, flange, and plug to the fresh concrete so that the flange is level with the surface of the concrete. Depending on the concrete type you may need to do some trowelling to ensure a flat surface around the tube. See Figure 7 on page 23.

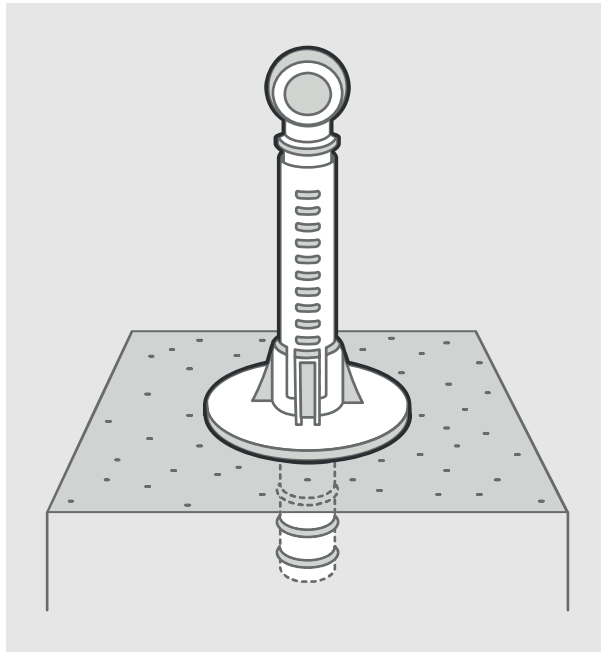

1111-091

Figure 7 Plugged Tube in Fresh Concrete

4. When the concrete has hardened, remove the plug and the flange from the tube. Leave the tube in place.
5. Use a flat-head screwdriver or other suitable tool to crack the concrete at the bottom of the tube. This is necessary because during the curing of the concrete a solid surface forms in the bottom of the tube. Cracking this surface helps the air in the tube to reach equilibrium with the humidity in the concrete. See Figure 8 below.

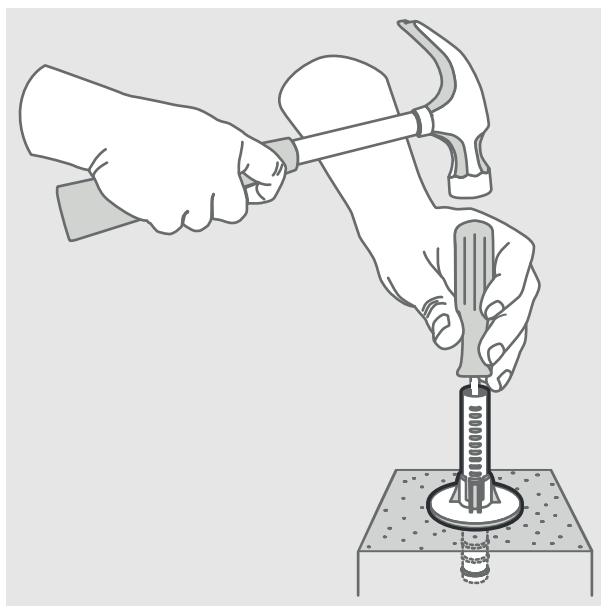

1111-092

Figure 8 Cracking the Concrete at the Bottom of the Tube

6. Clean the concrete dust at the bottom of the tube using a vacuum cleaner.
7. Now you have a clean borehole that reaches to the correct depth, and a plastic tube in it. Continue from section Inserting the Probe and Sealing the Hole on page 24.

Inserting the Probe and Sealing the Hole

1. Press a protective cover (19268HM) on the plastic tube and turn it so that it slides down freely. Press the protective cover against the concrete surface so that the sealing compresses slightly. Turn the cover 90° to lock it in place.

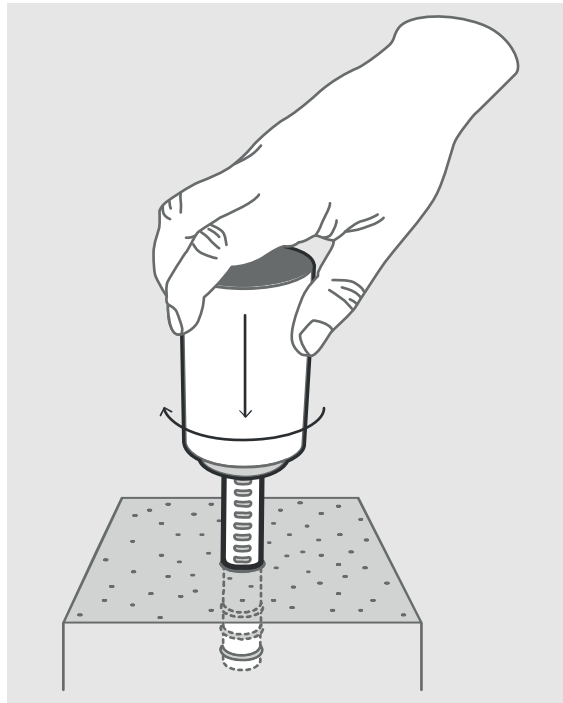

1111-131

Figure 9 Locking the Cover in Place

2. Insert the HMP40S probe into the tube and keep inserting the cable until the probe touches the bottom. Seal the tube with the rubber plug on the cable. See Figure 10 on page 25.

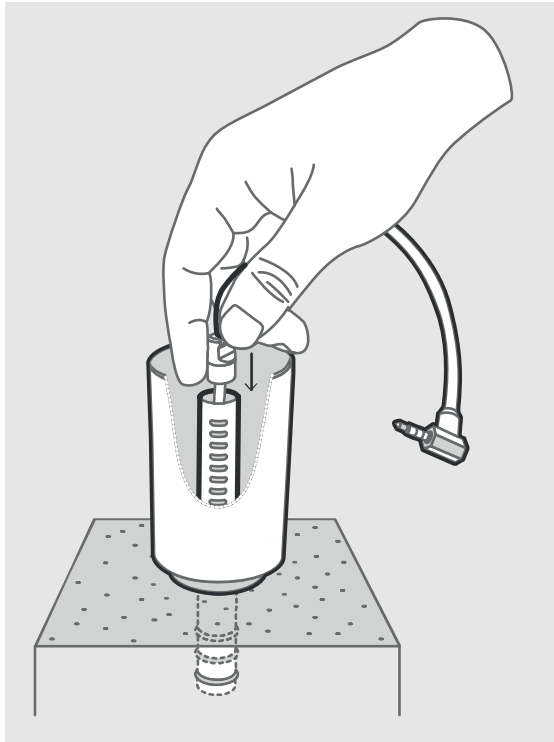

1111-132

Figure 10 Sealing the Tube with a Rubber Plug

3. Fold the cable inside the protective cover and close the lid. Leave the probe to stabilize before starting the measurements.

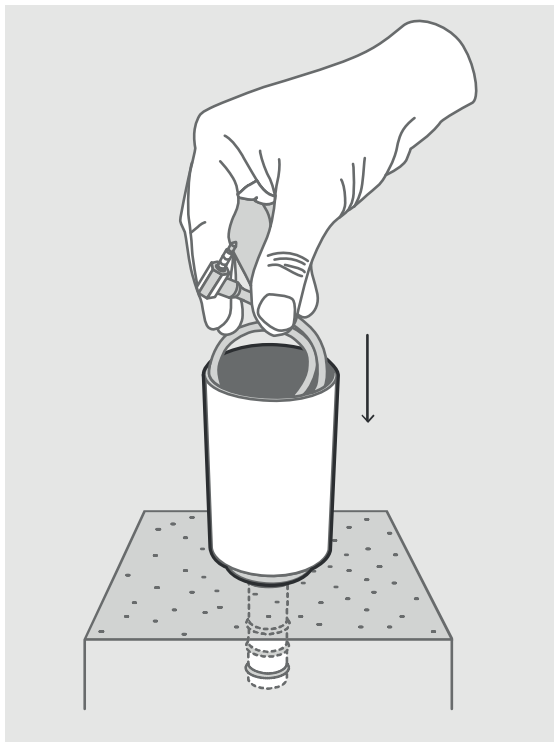

1111-133

Figure 11 Cable Folded in the Protective Cover

If you cannot leave the probe in the tube, plug the tube using a rubber plug (233976). This means you will have to insert the probe when taking the measurement, and wait for about 30 minutes for stabilization.

It is recommended that you leave the probe into the tube as this ensures the best possible reliability of the readings.

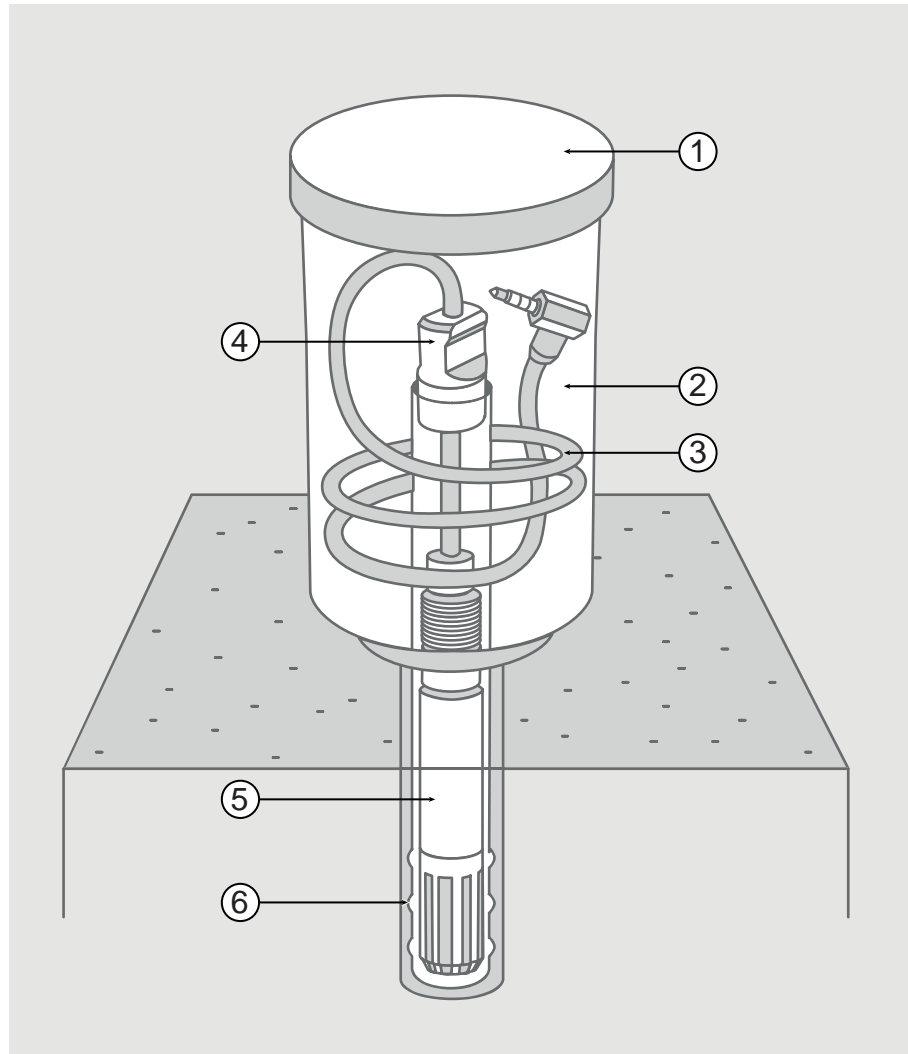

1111-134

Figure 12 Recommended Setup During Stabilization

where

- 1 = Lid
- 2 = Protective cover
- 3 = Probe cable
- 4 = Rubber plug
- 5 = Probe
- 6 = Plastic tube

Alternate Sealing Materials

Plastic Tubes

Inserting a plastic tube in the hole is always necessary to ensure that you are measuring the humidity of the concrete at the desired depth. Vaisala recommends using the tubes in the plastic tube set (19266HM) since they provide a seal around the bottom part of the tube with the three thin ridges around the tube. Sealing the crack between the tube and the hole is important when a drilled hole is used.

If you use a different plastic tube, provide an equivalent seal around tube.

Rubber Plugs

If you need to use a substitute material for the rubber plugs (233976), you can use putty, tape, or other plugs of appropriate size to plug the plastic tube. Do not use hygroscopic materials or thin tapes such as masking tape.

HMP40S probe includes an integrated rubber plug with the cable, so you always have a rubber plug available when you leave the probe to stabilize in the plastic tube.

Protective Covers

The protective covers (19268HM) are not required for measurement accuracy, but they are recommended for the following reasons:

- They keep the probe cable and the quick connector clean during the long stabilization period.
- They make the prepared borehole easy to find visually, preventing accidental interference with the measurement and damage to the probe.

Performing the Measurement

The humidity of the hole reaches equilibrium with the humidity of the concrete approximately in three days. Before this, you cannot obtain reliable measurements.

1. If the probe has not been left to stabilize inside the tube:
 - a. Remove the rubber plug from the tube.
 - b. Insert the HMP40S probe in the tube.
 - c. Seal the tube with the rubber plug on the cable.
2. Connect the probe to the HM40 indicator.
3. Turn on the HM40 indicator.
4. Switch to RH quantity.
5. Switch to graph view and verify that the readings are stable. If you inserted the probe in step 1, **wait for at least 30 minutes** before continuing to the next step.
6. Write down the measured RH value. You can also press the **Hold** button tag the point.
7. Turn off the HM40 and disconnect the cable.
8. If you do not wish to leave the probe into the tube, remove the probe and close the tube with the rubber plug.

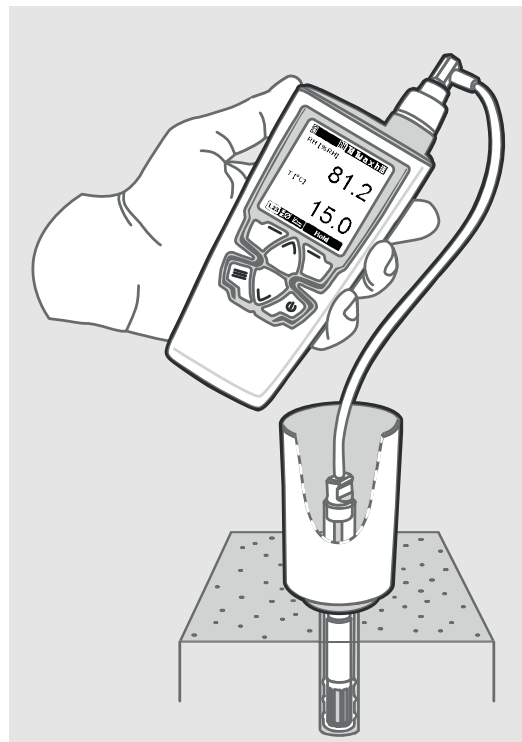

1112-005

Figure 13 Performing the Measurement

Ending the Measurements

When the concrete is dry enough and measurements are no longer necessary, remove the probe and the protective cover. Pull out the plastic tube.

This page intentionally left blank.

CHAPTER 4

USING THE HM40 INDICATOR

This chapter introduces the functions of the HM40 indicator and the HMP40S probe.

HM40 Indicator

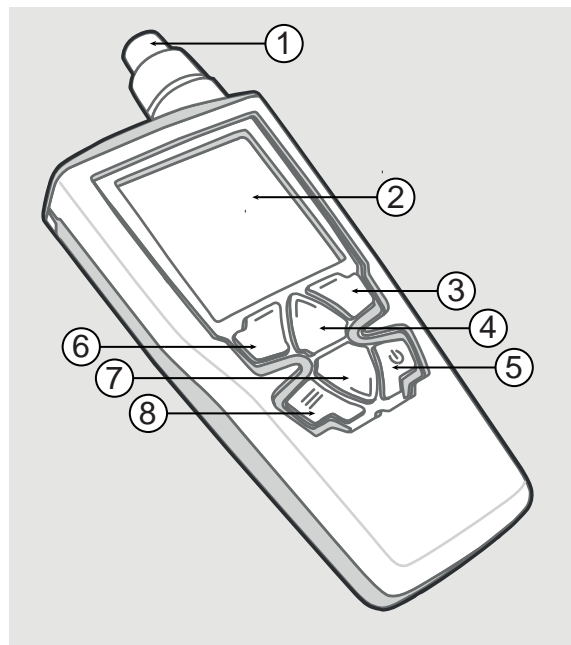

1111-136

Figure 14 HM40 Indicator for Structural Humidity Measurements

where

- 1 = Quick connection adapter for HMP40S probe
- 2 = Display
- 3 = Right function button
- 4 = Up arrow button
- 5 = Power button
- 6 = Left function button
- 7 = Down arrow button
- 8 = Menu button

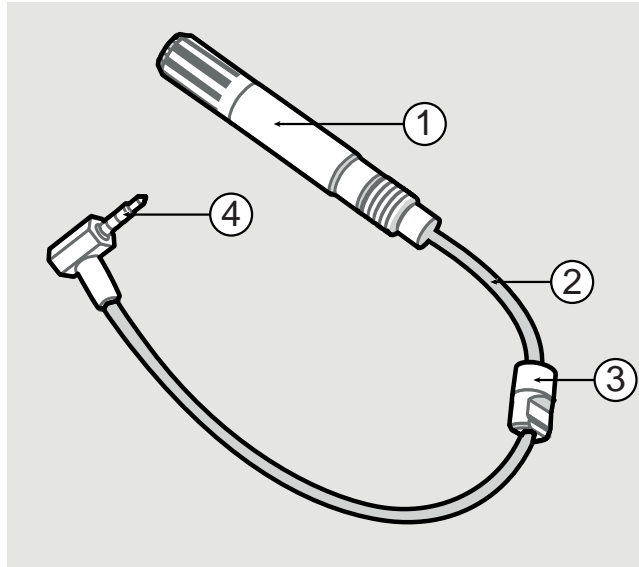

1112-008

Figure 15 HMP40S Probe

where

- 1 = HMP110 probe
- 2 = 30 cm cable
- 3 = Integrated rubber plug
- 4 = Cable connector to HM40 indicator with quick connection adapter

Batteries

The HM40 indicator is powered by two AA-size batteries. You can use the following battery types:

- Alkaline (IEC-LR6)
- Lithium (IEC-FR6)
- NiMH (IEC-HR6)

CAUTION

Do not mix batteries of different types. Both batteries must be of the same type.

CAUTION

Observe the storage and operation instructions of the battery manufacturer.

Alkaline batteries are the standard choice in non-rechargeable batteries. They are a good match for the power requirements of the HM40 indicator.

Lithium batteries are a good choice if you need the longest battery life or best capacity in low temperatures. Lithium batteries are not rechargeable. Do not confuse them with rechargeable lithium-ion batteries, which cannot be used in HM40.

NiMH batteries are rechargeable. Two NiMH batteries are included with the USB recharger that is available from Vaisala as an option. For order codes, see section Spare Parts and Accessories on page 63.

Battery Life

Typical operation time that is achieved with alkaline batteries is 100 hours. The operation time will be shorter if the display backlight is used, and if the operation environment is cold.

NOTE

HM40 does not automatically power off when it is not used. To conserve batteries, turn the meter off when you are not using it or configure a suitable automatic power off delay (see Power off on page 48).

Charging

The optional USB charger (Vaisala order code 229249SP) provides a convenient way to charge two NiMH batteries from any powered USB port (for example, from a laptop computer).

1. Place the rechargeable batteries in the charger and plug it into a USB port. The blue LED on top of the charger starts to blink.
2. When the LED stops blinking and stays on, the batteries are charged. The charging time is several hours for two fully discharged NiMH batteries.

If you are not using a Vaisala-supplied charger and rechargeable batteries, read and follow the manufacturer's own charging instructions.

WARNING

Do not attempt to charge non-rechargeable (alkaline or lithium) batteries! Doing so leads to a risk of battery leakage, equipment damage, and risk of explosion and/or fire.

Connecting the Probe

NOTE

It is recommended that you turn off the HM40 indicator before connecting or disconnecting the probe.

The HM40 indicator that is delivered with the SHM40 kit (or when ordering the HM40S) has an adapter with a 3.5 mm TRRS connector socket on top. The cable of the HMP40S probe has the equivalent plug. To connect the probe, simply plug in the probe cable to the connector.



1111-135

Figure 16 Connecting the Probe

First Startup

1. Remove the yellow transport protection cap from the HMP40S probe, and connect the probe to the HM40 indicator.
2. Open the battery cover and insert two AA-size batteries.
3. Close the battery cover and turn on the HM40 by pressing the Power button. If the HM40 does not turn on, check the battery orientation. Replace the batteries with fresh/recharged ones if needed.

Initial Settings

When you power on the HM40 indicator for the first time (or after a factory reset of the settings), you must first select the operation language. You will then be asked if you want to change the following settings:

- Units
- Date
- Time

If you answer Yes to the question (recommended), the HM40 will show the settings screens before showing the measurement view. Use the arrow and function buttons to select. For more information, see section Settings Submenu on page 45.

NOTE

HM40 indicator will retain the date and time even during battery changes. The clock will have to be set again only if the indicator is without battery power for several hours.

Quantities Explained

The table below describes the quantities measured by the HM40 indicator with the HMP40S probe. All of the quantities are measured or calculated when the HM40 is on, independent of what is currently displayed.

NOTE

Relative humidity (RH) and temperature (T) are the most important quantities for structural humidity measurement.

Table 5 Quantities Output by HM40S

Quantity	Symbol	Unit(s)	Description
Relative humidity	RH	%	Ratio of the partial pressure of water vapor in the air to the saturation vapor pressure of air at the current temperature.
Dewpoint	Td	°C °F	Temperature at which the water vapor in the air will condense into water at the current pressure. When the dewpoint is below 0 °C, the HM40 outputs frostpoint (Tf) instead of dewpoint.
Wet bulb temperature	Tw	°C °F	The minimum temperature that can be reached by evaporative cooling in the current conditions.
Absolute humidity	a	g/m ³ gr/ft ³	Quantity of water in a cubic meter (or cubic foot) of air.
Mixing ratio	x	g/kg gr/lb	Ratio of water vapor mass per kilogram (or pound) of dry air.
Enthalpy	h	kJ/kg btu/lb	Sum of the internal energy of a thermodynamic system.
Temperature	T	°C °F	Temperature in Celsius or Fahrenheit scale.

Screen Layout and Controls

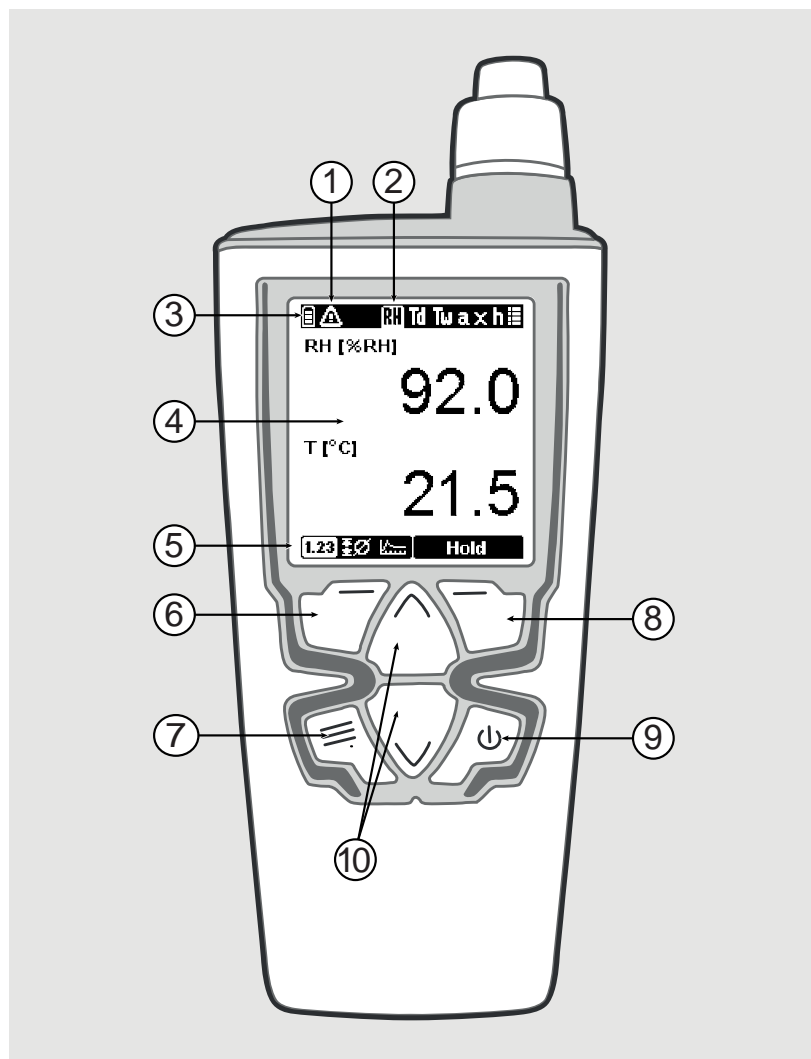

1112-004

Figure 17 Screen Layout





where

- 1 = Alert indicator
- 2 = Currently selected quantity
- 3 = Battery indicator
- 4 = Measurement display area
- 5 = Currently selected view
- 6 = Left function button: change view
- 7 = Menu button: enter menu
- 8 = Right function button
Long press: tag point, short press: tag point and hold screen
- 9 = Power button
Long press: power on/off, short press: activate backlight
- 10 = Arrow buttons: change quantity

NOTE Pressing the right function button holds the screen and tags the current measurement point. See section Hold and Tag on page 40.

Indicators

Table 6 Indicators on the HM40 Display

Symbol (s)	Name	Description
	Battery charge	Fresh batteries will always show three bars. When the indicator shows two bars, the voltage of the batteries has started to drop. When there is a single (blinking) bar left, you should replace the batteries. HM40 will turn off automatically when the battery voltage drops too low.
	Alert	This indicator is shown next to the battery charge indicator if there is a measurement problem. The most likely cause is that the probe is currently disconnected, or the battery is low.
	Quantity	The selected quantity is highlighted by a light frame. The symbol on far right stands for all quantities.
	Calibration reminder	This indicator appears when you have set up a calibration reminder and the calibration is due. The indicator is shown until you calibrate the probe.

Numeric View

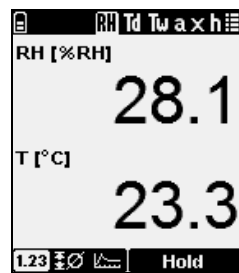

The Numeric view shows the currently values of the selected humidity quantity and temperature.

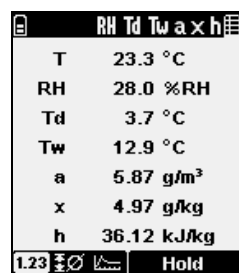

In the all quantities view the font is smaller to fit all values on screen.

Statistics View

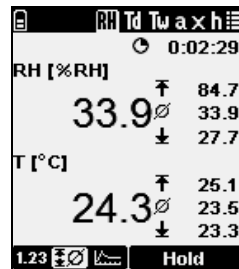

The Statistics view shows the current value of the selected quantity, as well as the maximum, average, and minimum value since the measurement was started. There is also a counter that shows how long the measurement has been running.

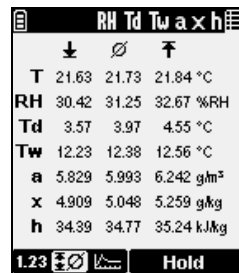

The counter for measurement time is not shown in the all quantities view.

The icons are:

- ↑ Maximum
- ∅ Average
- ↓ Minimum
- ⌚ Measurement time

Graph View

The Graph view shows a continuously updating graph of the selected quantity and temperature. The graph limits and spacing adjust dynamically to show the full range of measurements.

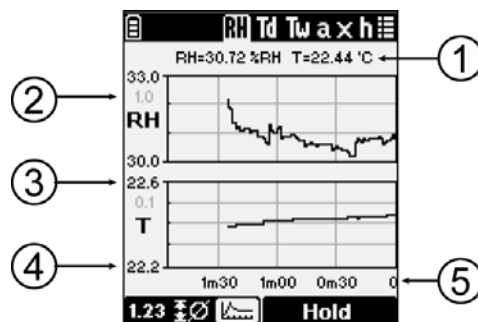

1111-096

Figure 18 Elements of the Graph View

where

- 1 = Current values
- 2 = Vertical spacing of the grid
- 3 = Graph maximum
- 4 = Graph minimum
- 5 = Time

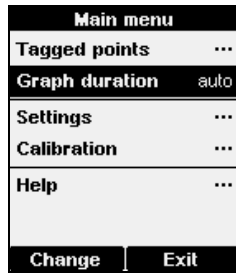

The timescale of the graph can be changed in the **Main menu**. By default, the graph will automatically change the timescale to fit the measured data. If you select a short timescale, only the most recent data will be visible.

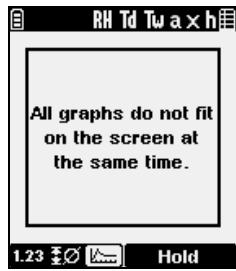

The graph view is not available in the all quantities view. Select a single quantity to show the graph.

NOTE

HM40 indicator has no permanent memory for graph data. When the HM40 is turned off, the graphs are cleared. Only tagged points are stored in permanent memory. To avoid losing graph data while working, set a suitable delay for the automatic power off (see Power off on page 48) or disable it.

Hold and Tag

If you press the right function button (**Hold** button) in a measurement view, two things happen:

- The measurement view freezes until you press the **Release** button.
- The latest measurement point is tagged (marked and stored in temporary memory). See section Tagged Points on page 42.

Tagged points are shown in the graph view as small dots below the graphs.

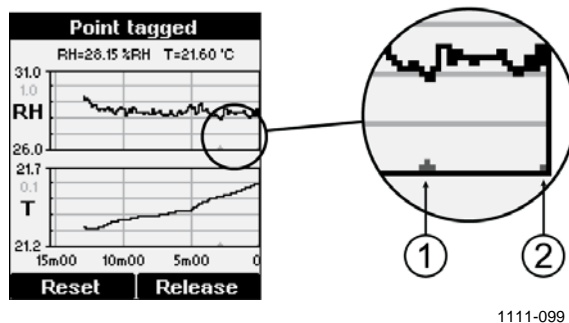

1111-099

Figure 19 Tagged Points in the Graph View

where

- 1 = Previously tagged point
- 2 = New tagged point

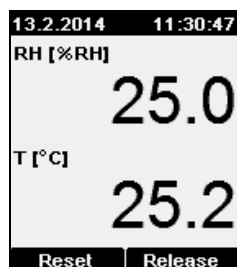

When the screen is held, the top of the display displays the current date and time. This is useful when you want to record the current data (take a photograph or write it down).

If date and time have not been set, the top of the screen will simply read “HOLD”.

CAUTION

When the view is held, you can reset all measurement data by pressing the **Reset** button. This will clear all graphs and tagged points.

NOTE

If you keep pressing the right function button (long press), the HM40 will tag the point without freezing the screen.

Main Menu

You can open the menu from the measurement view at any time by pressing the menu button.

If you are already in the menu, pressing the menu button returns you to the measurement view. If you are in a submenu, the menu button returns you to the previous menu level.

Main menu	
Tagged points	...
Graph duration	auto
Settings	...
Calibration	...
Help	...
Enter	Exit

Use the arrow buttons to move up and down in the menu, and function buttons to operate the menu options. Typical functions in the menus are:

- **View** and **Enter** open the selected menu option or submenu.
- **Change** and **Set** change the value of the selected option.
- **Back** returns to the previous menu view.
- **Exit** closes the menu and returns to the measurement view.

NOTE

Some menu screens have more content than can be visible at one time. This is indicated by a scroll bar that appears on the right side of the screen. Use the arrow buttons to scroll up and down.

Tagged Points

Main menu	
Tagged points	...
Graph duration	auto
Settings	...
Calibration	...
Help	...
View	Exit

Select **Tagged points** in the main menu to see the list of stored points and values.

Tagged points		
Time	RH [%RH]	T [°C]
2:35:58	39.2	22.8
2:40:22	38.0	23.0
2:41:46	38.0	23.0
View	Back	

Time and temperature value are always shown for each tagged point. The shown humidity quantity is the same as has been selected in the measurement view. If the all parameters view has been selected, RH is shown instead.

Point 3 / 3	
3.1.2014 2:41:46 (0:01:02 ago) G1030024	
T	23.0 °C
RH	38.0 %RH
Td	7.9 °C
Tw	14.4 °C
a	7.84 g/m ³
x	6.65 g/kg
h	40.18 kJ/kg
Delete	Back

The data stored for each tagged point includes:

- Time when the point was tagged.
- Serial number of the probe that was used (useful for identifying the point).
- Measured value of each quantity.

Press the **Delete** button to delete the point that is currently shown. To delete all points in memory, hold down the **Delete** button.

NOTE

HM40 can store up to 40 tagged points. If a new tagged point is stored when the memory is full, the oldest tagged point is silently deleted to make room for the new point.

Graph Duration

Graph duration	
auto	×
1.5 min	
3 min	
7 min	
15 min	
30 min	
1 h	
Set	Back

In the **Graph duration** screen, you can select the timescale of the Graph view. The shortest selectable timescale is 1.5 minutes, the longest 32 hours.

You can also select **Autoscale**, which means that the timescale will automatically adjust to show all of the measurement data in memory, up to the maximum of 32 h.

Settings

Settings	
Language	English (en)
Units	...
Time & Date	...
Pressure	1013.3 hPa
Reminder	Every 3 mths
Backlight	Delay (30 s)
...	...
Choose	Back

Opens the **Settings** menu. The menu options are described in section Settings Submenu on page 45.

Calibration

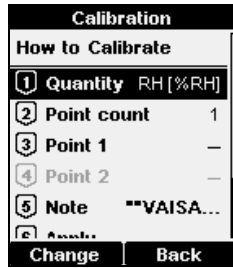

In the **Calibration** submenu, you can perform an adjustment procedure that corrects the humidity and temperature measurement of the meter.

For more information and the adjustment procedure, see section Calibration on page 52.

Help

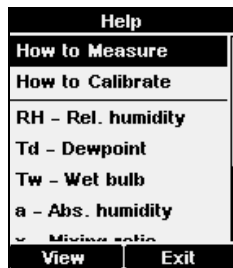

Opens a menu with help topics on measurement, calibration, and the measured quantities.

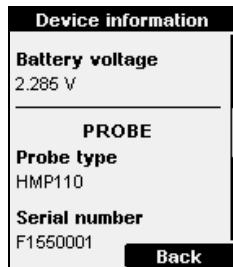

The help menu also includes a device information screen where you can view technical information about your HM40 indicator and connected probe.

Settings Submenu

Language



In the **Language** screen, you can change the display language of the meter. The choices are:

- English (en)
- German (de)
- French (fr)
- Finnish (fi)
- Spanish (es)
- Swedish (sv)
- Chinese (zh)
- Russian (ru)
- Japanese (jp)
- Portuguese (pt)

Units

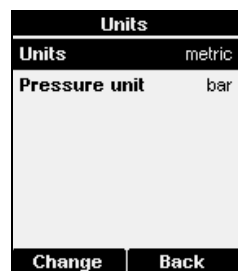

The **Units** setting determines the measurement system that is used for the quantities:

- Metric
- Non-metric

The Pressure unit is set separately:

- hPa
- bar
- atm
- PSI

Time & Date



In the **Date** setup screen, you can set the current date:

- **Arrow buttons** change the selected value
- **Left function** button selects the next value (year, month, or day).
- **OK** button stores the date and returns to the Settings menu.

After setting the date, set the desired date format using the **Formatting** option in the Time & Date menu.



In the **Time** setup screen, you can set the current time:

- **Arrow buttons** change the selected value.
- **Left function** button selects the next value (hours, minutes, or seconds).
- **OK** button stores the time and returns to the Settings menu.

After setting the time, select 24h or 12h clock using the **Formatting** option in the Time & Date menu.

Pressure



In the **Pressure** setup screen, you can set the current ambient pressure. The pressure information is used when calculating certain humidity quantities, such as mixing ratio (symbol x).

If the ambient pressure differs significantly from the default setting of 1.0132 bar (due to high altitude, for example), set the correct pressure value so that the HM40 indicator can calculate the measurement correctly.

Reminder



You can set a reminder for calibrating the probe with the **Reminder** selection. You can choose a preferred calibration interval of 3, 6, 12, or 24 months. Calibrating the probe resets the calibration interval. To remove the reminder from use, select **Disabled**.

Note that you must set the correct date in the indicator for the calibration reminder to appear as intended.



The calibration reminder appears one month before the preferred calibration date is due.

To continue displaying the reminder for this interval, select **Snooze**. The reminder will appear again at each power-on.

To hide the reminder, select **Close**. If you do not calibrate within a month, the reminder will appear again.

NOTE

Calibrating any parameter in the probe resets the calibration interval. This means that if you leave one parameter uncalibrated in a calibration session, the reminder will not appear separately for that parameter.

Backlight



Always on: Screen is always lit. This option will shorten the battery life significantly.

Always off: Screen is always unlit. This option provides the best battery life.

Delay (30s): Backlight will automatically turn on when the user presses any button. The backlight will turn off after 30 seconds of inactivity.

Dimmed: Screen is always lit with a dim backlight.

Battery

Use the Battery setting to tell the HM40 what kind of batteries are installed. This will help to scale the battery indicator correctly. The options are:

- Alkaline
- Rechargeable

Power off

The **Power off** setting defines how long the device can remain inactive before powering off automatically. The time limit options are 10, 30, and 60 minutes. Select **Never** to disable automatic power off.

NOTE

HM40 has no permanent memory for graph data: when the meter is turned off, the graphs are cleared. Only tagged points are stored in permanent memory. To avoid losing graph data while working, set a suitable delay for the automatic power off or disable it.

Navigation

The Navigation setting affects the behavior of arrow buttons in the measurement view:

- **Normal:** Up arrow moves quantity selector left, down arrow moves it right
- **Inverted:** Reverses the direction

Rounding

The Rounding setting affects the number of decimal places that are used to show the measurements:

- **On:** Measured values are rounded to one decimal place.
- **Off:** Measured values are shown with two decimal places.

Factory Settings

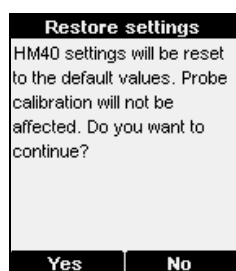

The **Factory settings** option restores all settings to their default values. Probe calibration is not affected.

This page intentionally left blank.

CHAPTER 5

MAINTENANCE

This chapter provides information that is needed in basic maintenance of the SHM40 kit.

Periodic Maintenance

Cleaning

HM40 indicator can be cleaned by wiping it with a moist cloth.

If the filter on the HMP40S probe becomes contaminated, it is very likely to affect the humidity measurement since residue on the filter will retain some moisture. Dirty filters must be replaced.

Do not use solvents to clean the HM40 indicator or the HMP40S probe. Do not spray anything directly on the HMP40S, since that may deposit impurities on the sensor.

CAUTION	Do not immerse the HM40 indicator or the HMP40S probe in liquid.
----------------	--

CAUTION	Do not attempt to clean the sensor element that is located inside the filter. Any touching (or blowing with pressurized air) may damage it. If the measurement accuracy cannot be restored by calibration and adjustment, it is time to replace the HMP40S probe.
----------------	---

Changing the Filter

1. Twist the filter counter-clockwise to open it.
2. Turn the filter until it can be removed. Do not touch the sensors when pulling it away.
3. Install the new filter and tighten it.

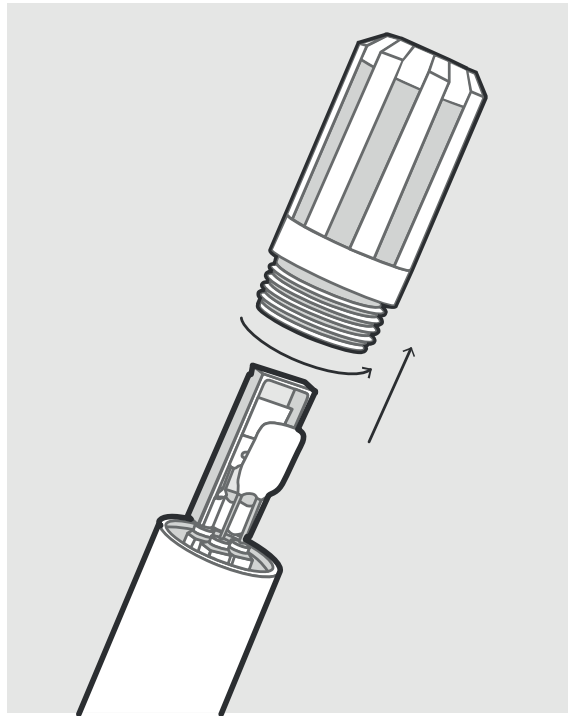

1112-006

Figure 20 Changing the Filter

Calibration

The humidity measurement accuracy of the HMP40S probe should be checked once a year. You can do this yourself using a humidity reference (for example, the Vaisala Humidity Calibrator HMK15), or send the probe to a Vaisala Service Center for calibration. See the back cover of this manual for contact information.

You can set a reminder for calibration at preferred calibration intervals (3, 6, 12 or 24 months). See section **Reminder** on page 47.

If the calibration shows that the measurement accuracy is no longer within specification, the probe must be adjusted. If accuracy cannot be restored with adjustment, the probe must be replaced. All probes that are ordered from Vaisala are delivered calibrated. See section **Spare Parts and Accessories** on page 63.

CAUTION

If you think the HM40 is not measuring humidity or temperature correctly, calibration and adjustment is not the first thing to do. Try the following first:

- Make sure nothing is interfering with the measurement: heat sources, temperature differences, or condensation.
- Check that there is no moisture on the probe. If the sensor has become wet, you must allow it to dry before you can measure.
- Always wait for the measurement to stabilize.

NOTE

For an introduction to calibration, order or download the free calibration book from Vaisala at the following address:

www.vaisala.com/calibrationbook

Calibrating the HMP40S Probe Using HMK15 Humidity Calibrator

The HMK15 Humidity calibrator allows you to produce known humidity environments using saturated salt solutions.

NOTE

Performing a good calibration takes some time and preparation. Read the HMK15 User's Guide before performing your first calibration with the HMK15.

NOTE

In 2-point calibration, the first point requires a < 50 %RH humidity reference, and the second point must be > 50 %RH. There must also be at least a 30 percentage point difference between the references.

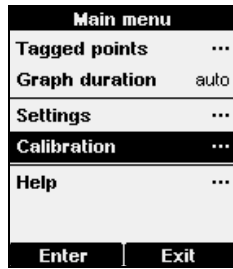

1. Press the Menu button and select the **Calibration** submenu.

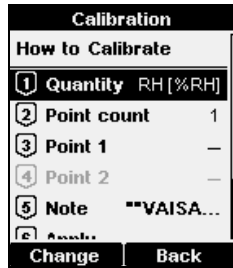

2. Select the quantity to be calibrated at menu item **[1] Quantity**. You can calibrate Temperature (T) or Relative Humidity (RH) measurement. All other humidity quantities are calculated from RH and T, so they will also be adjusted.

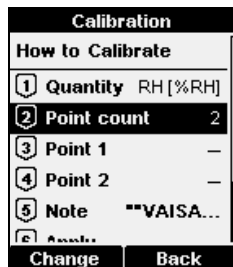

3. Select the number of calibration points at menu item **[2] Points**. You can perform a 1-point or 2-point calibration.

For 2-point calibration, you need two reference environments. For example, LiCl and NaCl salt chambers provide 11 %RH and 75 %RH references.

NOTE: In 2-point calibration, the first point requires a < 50 %RH humidity reference, and the second point must be > 50 %RH. There must also be at least a 30 percentage point difference between the references.

4. Place the probe in the first reference environment (first calibration point). Wait 20 – 40 minutes for the reading to stabilize.

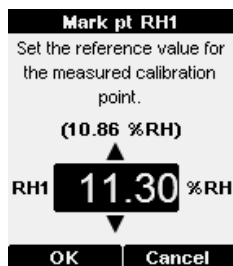

5. Select menu item **[3] Point 1** and press the Set button. The HM40 now shows the currently measured value of the selected quantity. Set the reference value using the arrow buttons and press the OK button.

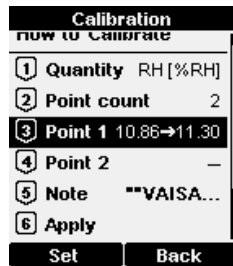

The correction to the measurement at point 1 is now shown in the text for menu item [3]. If you are only doing a 1-point calibration, skip to step 8.

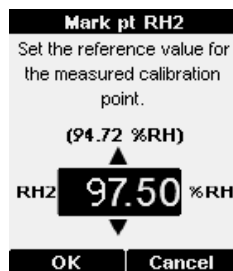

- Place the probe in the second reference environment (second calibration point). Wait 20 – 40 minutes for the reading to stabilize.
- Select menu item [4] **Point 2** and press the **Set** button. The HM40 now shows the currently measured value of the selected quantity. Set the reference value using the arrow buttons and press the OK button.

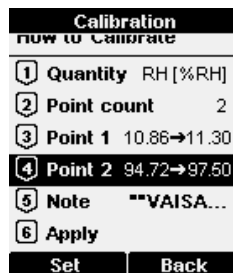

The correction to the measurement at point 2 is now shown in the text for the menu item [4].



- Select menu item [5] **Note** to edit the calibration info text that is stored in the probe. Edit the text using the select button and arrow keys. When done, select the OK character in the bottom right corner to save the changed text.

To exit without saving, press the **Cancel** button.

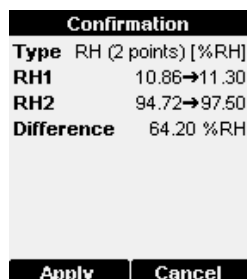

- Select menu item [6] **Apply** to save the calibration in the probe. Check the applied corrections in the confirmation screen and press the **Apply** button.

To exit without applying the correction, press the Cancel button.

Repair Maintenance

There are no user serviceable parts inside the housing of the HM40 indicator or the HMP40S probe. Depending on the malfunction, repair by a Vaisala Service Center may be possible.

Replacement HM40 indicators, HMP40S probes, and measurement accessories are available from Vaisala. See section Spare Parts and Accessories on page 63.

CHAPTER 6

TROUBLESHOOTING

This chapter describes common problems, their probable causes and remedies, and provides contact information for technical support.

Avoid Condensation and Rain

If the humidity sensor element on the probe becomes wet, the probe cannot measure until the sensor is dry again. Avoid rain and conditions where condensation can form on the sensor.

Do not use the transport protection cap if the probe is wet, since it will prevent the probe from drying.

CAUTION

Do not touch the sensor or blow on it to dry it out.

Problem Situations

Table 7 Some Problem Situations and Their Remedies

Problem	Possible Cause	Remedy
Readings on the HM40 screen are replaced by asterisks '*****'.	Probe disconnected.	Connect a HMP40S probe to the HM40 indicator.
	Probe connection loose or dirty.	Disconnect the probe, check and clean the connector. Check that the quick connector on the HM40 sits tightly. Reconnect the probe.
	Very low battery voltage.	Check the battery indicator. Replace batteries with fresh ones.
The screen is blinking on and off.	Very low battery voltage.	Replace batteries with fresh ones.
When performing the humidity measurement in a borehole, the measurement is not stable even after waiting.	The measurement hole has not been adequately prepared.	The borehole may not have been cleaned or sealed during stabilization. Check and prepare the hole again.
	The humidity in the concrete has not reached equilibrium with the air in the borehole.	The borehole needs a longer stabilization time. Re-plug the hole and measure again later.
Measured humidity reading is much higher than expected.	HMP40S probe in need of calibration and adjustment.	Adjust and calibrate the probe. See section Calibration on page 52.
	HMP40S probe has been stored in wet conditions.	Allow the probe and SHM40 case to dry out before resuming measurement.
Measured humidity reading is much lower than expected.	HMP40S probe in need of calibration and adjustment.	Adjust and calibrate the probe. See section Calibration on page 52.
	Borehole is not deep enough.	Check the borehole depth; see section Measurement Depth on page 16.

Technical Support

For technical questions, contact the Vaisala technical support by e-mail at helpdesk@vaisala.com. Provide at least the following supporting information:

- Name and model of the product in question
- Serial number of the product
- Name and location of the installation site
- Name and contact information of a technically competent person who can provide further information on the problem.

For contact information of Vaisala Service Centers, see www.vaisala.com/servicecenters.

This page intentionally left blank.

CHAPTER 7

TECHNICAL DATA

This chapter provides the technical data of the SHM40 kit.

Specifications

Table 8 HMP40S Probe

Property	Description / Value
Relative humidity	
Measurement range	0 ... 100 %RH
Accuracy (incl. non-linearity, hysteresis and repeatability)	
Temperature range 0 ... +40 °C	
0 ... 90 %RH	±1.5 %RH
90 ... 100 %RH	±2.5 %RH
Temperature range -40...0 °C, +40...+80 °C	
0 ... 90 %RH	±3.0 %RH
90 ... 100 %RH	±4.0 %RH
Factory calibration uncertainty at +20 °C	±1.5 %RH
Humidity sensor	Vaisala HUMICAP® 180R
Stability	±2%RH over 2 years
Typical stabilization time in a borehole when the concrete and the probe are in the same temperature	30 min
Temperature	
Measurement range	-40...+80 °C (-40 ... +176 °F)
Accuracy over temperature range	
0...+40 °C	±0.2 °C (0.36 °F)
-40...0 °C, +40...+80 °C	±0.4 °C (0.72 °F)
Temperature sensor	Pt1000 RTD 1/3, Class B IEC 751
General	
Operating temperature range for probe	-40 °C...+80 °C (-40 ... +176 °F)
Probe diameter	12 mm
Probe length	71 mm
Cable length (standard cable)	0.3 m
Cable length (long cable)	2.7 m
Probe weight with standard cable	31 g
Probe housing material	Stainless steel
Probe filter and sensor protection	Membrane filter with chrome coated ABS plastic

Property	Description / Value
Cable material	Wire: PVC Jacket: PU
Cable connector	TRRS male 3.5 mm
Probe housing classification	IP65
Application-Specific Dimensions	
Borehole diameter needed	16 mm
Measurement depth with standard accessories	Min. 30 mm Max. 90 mm

Table 9 HM40 Indicator

Property	Description / Value
Operation temperature range for indicator with LCD display	-10...+60 °C (+14 ... +140 °F)
Storage temperature range	-30...+70 °C (-22 ... +158 °F)
Dimensions (HxWxD)	
Indicator with adapter	184 x 72 x 44 mm
Weight	
Indicator with adapter and batteries	240 g
SHM40 case with standard content	3.7 kg
Indicator materials	PC/ABS blend Acrylic display lens
Indicator adapter materials	Nickel plated brass and plastic overmolding
Housing classification	IP54
Mechanical drop endurance	1.0 m without the probe
Power-up time	< 3 s
Batteries	2 x AA sized, 1.5V (LR6)
Calculated parameters	Td, Tw, a, x, h
Menu languages	English, German, French, Finnish, Spanish, Swedish, Chinese (simplified), Russian, Japanese, Portuguese
Display	LCD (140 x 160 pixels)
Operation time (Alkaline batteries)	Typical 100 hours (without backlight)
Electromagnetic compatibility (EMC)	European Union directive EN61326-1 for portable equipment

Spare Parts and Accessories

Table 10 Spare Parts and Accessories

Description	Order Code
HM40 indicator with adapter and cable probe for concrete moisture measurements	HM40S
HM40 indicator with adapter	HM40SINDI
RH & T probe with cable for concrete moisture measurements	HMP40S
HM42 probe for tight spaces	HM42PROBE
HM46 stainless steel robust probe	HM46PROBE
Membrane filter for HMP40S probe	DRW010525
Adapter for indicator and cable quick connector	HM40SADAPTER
Cable for HMP40S probe	HMP40SCABLE
Long cable (2.7 m) for HMP40S probe	HMP40SCABLE2
Plastic tubes (12 pcs)	19266HM
Rubber plugs (12 pcs)	233976
Weather-proof carrying case with SHM40 filling	CASEFORSHM40SP
Light carrying case for HM40S	230245SP
Protective covers with lid (3 pcs)	19268HM
Plastic flanges (12 pcs) for wet concrete	26529HM
Long rubber plugs (12 pcs) for wet concrete	26530HM
USB recharger for HM40 indicator batteries	229249SP
Special cover set for HMK15	230914

Dimensions in mm

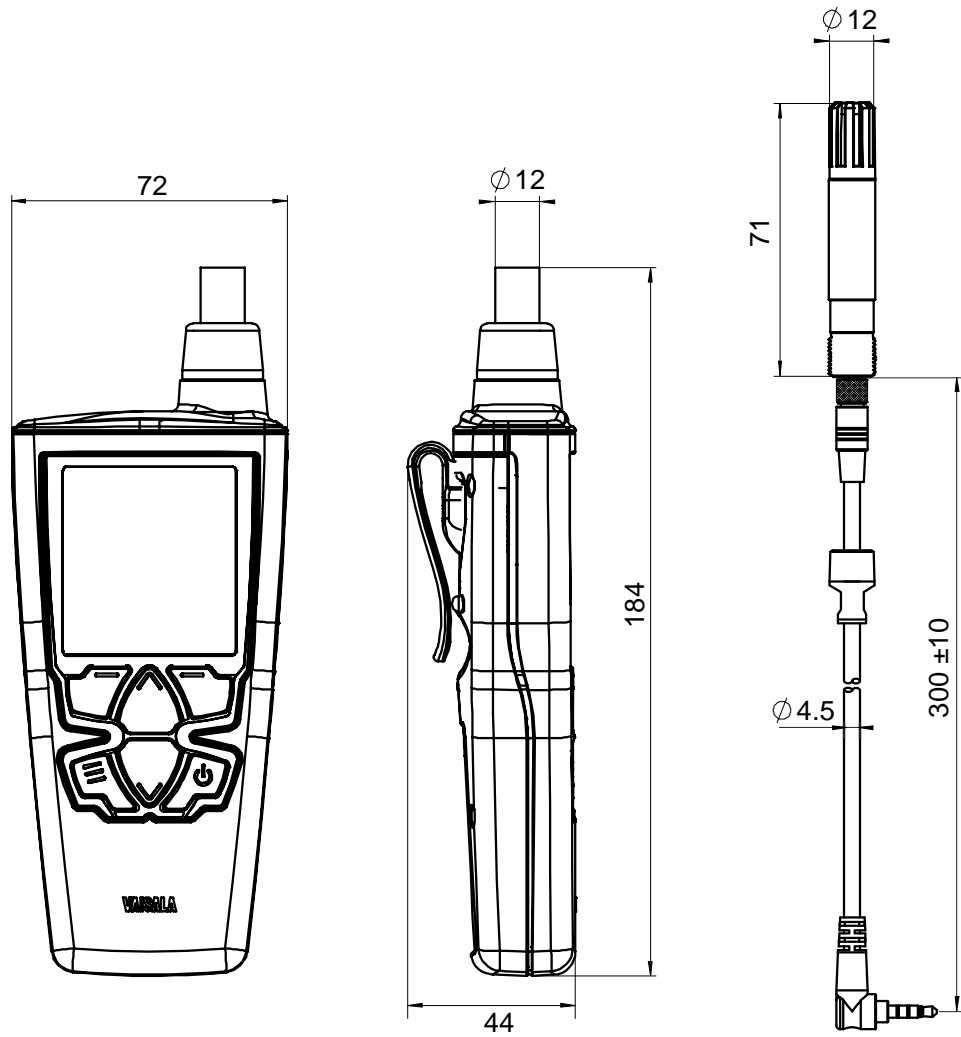

1111-097

Figure 21 HM40S Dimensions

APPENDIX A

HUMIDITY REPORT FORM

This appendix contains an example report form that can be used to record humidity measurement results in concrete.

HUMIDITY REPORT

Name and Location of Measured Structure	Floor or Section
---	------------------

Notes (for example: slab thickness, drying direction, casting date)

Location (building grid code or number)	Depth of borehole (cm)	Relative Humidity (%RH)	Temperature (°C/°F)	Air Temperature (°C/°F)	Air Relative Humidity (%RH)	Date and time

Measurement Instruments Used

Instrument or Probe, Serial Number	Last Calibration Date

Measurements Performed By

Name	Date
Company Name and Address	

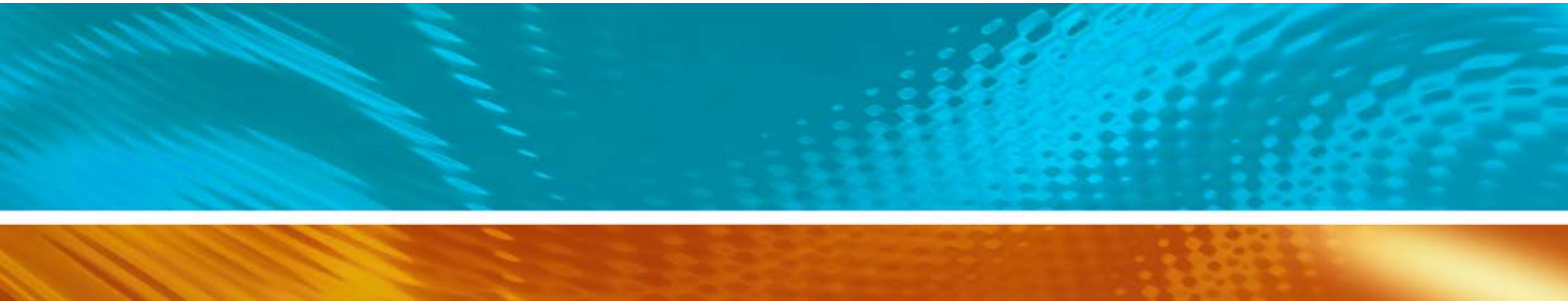

www.vaisala.com

