

■外形寸法図

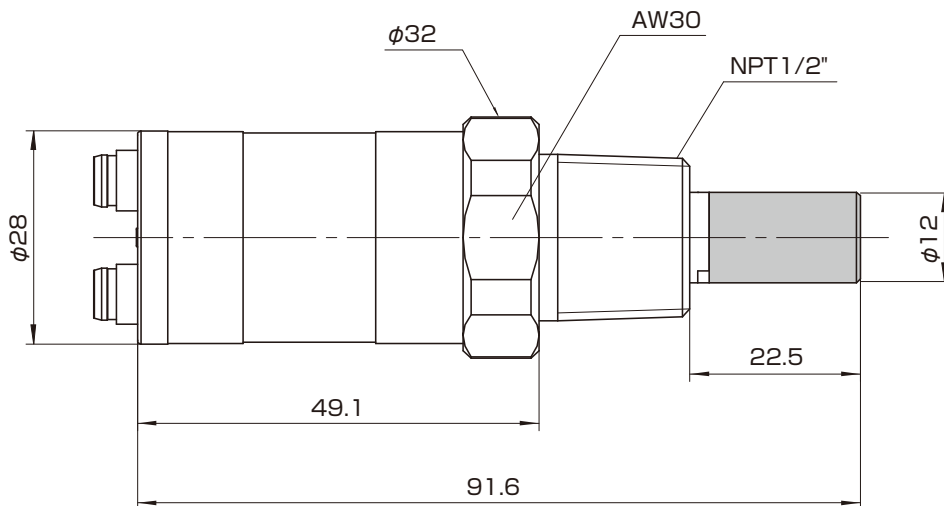

■結線図

デジタル信号用コネクタ

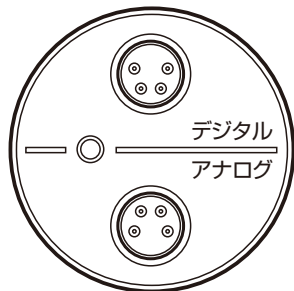

RS-485出力

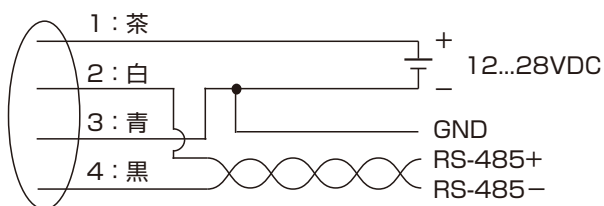
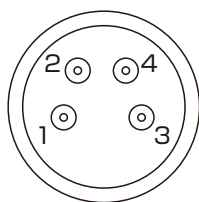

アナログ信号用コネクタ

電圧出力

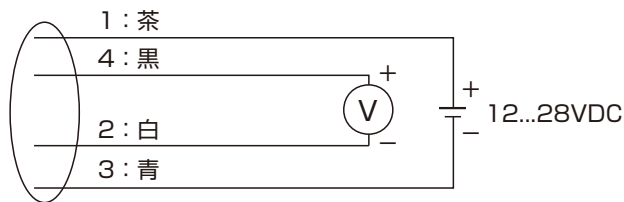
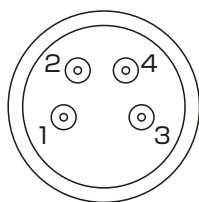

電流出力

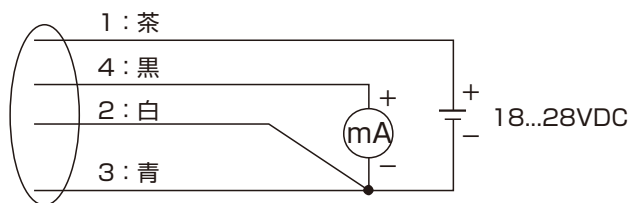

品名	小型露点変換器			
型式	DMT143	図番	DM-01-0171-3	
日付		承認	検図	REV
縮尺	／ 三角法	VAISALA		