

A low cost lightning protection system and its effectiveness

By: Nuwan Kumarasinghe

Electronics Engineer, Department of Meteorology, Colombo 07, Sri Lanka,
Telephone: 94-11-2681039, Fax: 94-11-2698311, e-mail: nuwan1960@yahoo.com

Abstract

Sri Lanka is a tropical country located between $5^{\circ} 55'$ to $9^{\circ} 51'$ North latitude and between $79^{\circ} 42'$ to $81^{\circ} 53'$ East longitude, and in the Asiatic monsoon region, the climate of the island could be characterized as both tropical as well as monsoonal. The island is seasonally affected by two regional scale wind regimes. The Southwest monsoon is from May to September and the Northeast monsoon from December to February. The inter-monsoon periods, the transition periods between the two monsoons are, from March to April and from October to November. The rainfall during these inter-monsoon periods is mainly due to convective thunderstorm activity.

More than 50 people are killed and billions of rupees worth property are damaged by lightning in Sri Lanka every year. Most lightning incidents are reported from the south western part of the island and mainly in mountainous area. Damages due to lightning increase day by day, in fact the intensity of lightning has been increased in recent fast. Most victims are humble persons who do not have enough knowledge in lightning and its hazards.

A pilot project was conducted in order to minimize the damages due to lightning. A village in Western Province in Sri Lanka namely *Janahitagama*, *Deraniyagala* is situated in a mountainous area. The village is surrounded by a huge rock. Lightning incidents were reported in many occasions. The Department of Meteorology Sri Lanka introduced a low cost lightning protection system for this village in 2001. The basic concepts of lightning protection were considered for the design of the system. 36 feet high lightning protection mast has been installed with earthing arrangement and all earth terminals were connected to this system. A series of awareness programmes on lightning were conducted in parallel. Ignorance of the poor people was the main reason for death occurrences in lightning damages. A detailed study was conducted in this village to check the effectiveness of the installation and awareness programme in the social behavior. A survey was conducted to collect information on lightning incidents occurred before and after the installation. Earth resistance was also being measured in each lightning protection mast. Earth resistance values of the past and the present were compared. An experiment was carried out by introducing earth conductivity enhancement chemical powder such as *Bentonite* and natural materials such as coconut coir peat and paddy dust. Experimentally showed that natural enhancement materials are equally good for earthing improvement.

1. Introduction

A village called *Janahitagama* is situated in a mountainous area in Deraniyagala, about 60 km from capital Colombo. More than seventy families were settled in this area in late 80's in a nearby area. The majority of the villagers are very poor and manage their lives with self employment and they cannot afford costly things. Lightning is very frequent in this area during the two inter monsoon periods March – April and October – November. Incidents with death and injuries were reported from this village several occasions in 1999

and year 2000. Villagers complaint to local authorities about these hazards and finally to ministry level request was made to the department of meteorology to inquire the situation. A team of experts including the deputy director of meteorology and I personally visited the area in late 2000.

2. Observations made during the survey

During the survey we have inspected more than 55 houses. None of them were equipped with lightning protection devices neither the villagers heard about that such a system can be used to protect their lives and property. Electricity was not available most of the houses and some people were using solar power for their day today needs. The few houses use mains power, the electrical earthing arrangement was not done properly. Some villagers do not realize the importance of the earth rod and they just ignore it .It was noticed that most of the damages in this village was due to direct lightning or side flash.



Fig. 1 A coconut tree affected by direct lightning



Fig. 2 A house damaged by lightning

3. Awareness programs

It is a clear fact that most villagers are not aware of the lightning and its fatal impacts to human, animals and property. The first thing we as the department of meteorology, concentrate to educate the villagers on lightning and its hazards. Low cost protection mechanism also being discussed during the awareness programme.



Fig. 3 An awareness programme conducted by the experts of the meteorological department

Many questions were raised by the villagers during the presentation. Handouts in *sinhalese* were distributed among them. Three deaths were reported in this village in 1999. Four persons still in semi paralyzed conditions. The villagers do not realize that all those damages were occurred mainly due to their ignorance.

4. A low cost lightning protection system

Installing an individual lightning protection system for each house in the village is a costly exercise. Therefore alternative low cost system was introduced for the village. Three main parts of a external lightning protection system consists of; air termination, down conductor and earth termination. Copper is the main material used for such systems.

A 36 ft. high G.I. pipe based tower together with copper air termination was used. Roughly about 275 US\$ would cost for such a protection tower. A total of 27 such lightning protection towers were installed in *Janahitagama* village. Villagers helped the technical staff of the department for the installation.

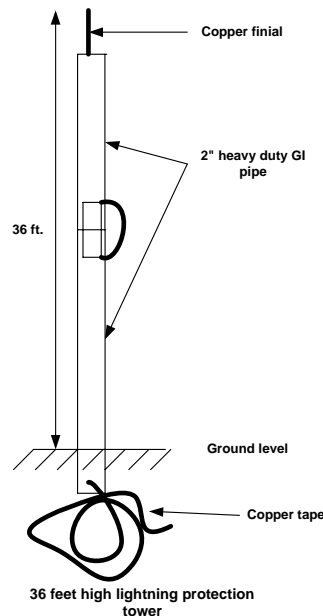

Fig. 4 Lightning protection tower

Among the factors considered for the design were; number of thunder days in the area, soil resistivity and soil type. Number of average thunder days in this area is about 130. As the soil type was gravel, sandstone with little clay, soil resistivity value was taken as 2000 ohm-m. In some places one lightning protection tower covers more than houses.

5. Earthing arrangement

Earthing is one of the most important aspect in a lightning protection system. When we measured the earth resistance of the electrical earth in some houses, it was noticed that many were beyond 1000 ohms. *Bentonite* is the main earth conductivity enhancement material used in lightning protection system installation. *Bentonite* is used as an earth-electrode backfill to reduce soil resistivity by retaining moisture. The clay consists largely sodium ions. It has the ability to hold its moisture content for a considerable period of time and to absorb moisture content for a considerable period of time and to absorb moisture from rainfall. Such earth conductivity material is comparatively expensive, therefore an alternative low cost material had to be used in this project. Coco peat and paddy dust or rice hulls were used as earth conductivity enhancement material. Coco peat and rice hulls can be found easily in many parts of the country.

5.1 Coconut or coco peat

Coco Peat (cocopeat), also known as coir pith or coir dust, is a byproduct of extracting fibres from the husk of a coconut. Coco Peat holds water rather

than shedding it like traditional peat does! It holds 8-9 times its weight in water. Coco Peat is very slow to disintegrate; it only begins to break down when it is 10 years old, long term benefits.

Coco peat has been introduced to the earth pit before install the earth electrode or rod.



Fig. 5 Earth electrode installation



Fig. 6 Coco peat

5.2 Paddy dust or rice hulls as an earth conductivity material

The main byproducts of rice milling are rice hulls or husk, rice bran, and brewer's rice. Rice hulls are generated during the first stage of rice milling, when rough rice or paddy rice is husked.

This material also commonly can be found in this area and therefore used as earth conductivity enhancement material.

Out of 27 lightning protection towers installed in the entire village, earthing arrangement of the 3 towers was done with coco peat and another three towers were done with paddy dust or rice hulls. *Bentonite* was used for the rest of the towers.



Fig. 7 Installation of lightning protection towers

6. Earth resistance measurement

The installation has been completed in mid 2001. A total of 27 lightning protection towers were installed. A total of nine towers were considered for this study. Earthing of three towers was done with coco peat, other three with paddy

dust or rice hulls and the last three towers with bentonite.

Measurements were taken in three occasions; at the time of the installation

(July 2001), January 2002 and September 2007. The following table shows the measurement results.

No.	Lightning protection tower	At the time of installation (July 2001)	January 2002	September 2007
1.	Lightning protection tower with Bentonite B1	1200 ohms	1100 ohms	125 ohms
2.	Lightning protection tower with Bentonite B2	1500 ohms	900 ohms	35 ohms
3.	Lightning protection tower with Bentonite B3	980 ohms	750 ohms	400 ohms
4.	Lightning protection tower with Coco peat C1	1500 ohms	1200 ohms	70 ohms
5.	Lightning protection tower with Coco peat C2	1100 ohms	660 ohms	38 ohms
6.	Lightning protection tower with Coco peat C3	580 ohms	500 ohms	45 ohms
7.	Lightning protection tower with Rice Hulls R1	760 ohms	700 ohms	100 ohms
8.	Lightning protection tower with Rice Hulls R2	1250 ohms	1100 ohms	55 ohms
9.	Lightning protection tower with Rice Hulls R3	1400 ohms	980 ohms	60 ohms

Table 1

These measurements were taken by using a digital earth tester.

7. Feedback from villagers on the protection system

We interviewed more than 50 persons in the village. They fall in three different age categories. Their

opinions and experiences are very important for future installations. In general, all the villagers are now aware about lightning and its possible hazards. They also have knowledge on precautionary measures and protection mechanisms of lightning. Their opinions are summarized in Table 2.

No.	Opinion on	Age between 10 -15	Age between 15 -35	Age more than 50
1.	Idea on lightning as a natural phenomena	56%	73%	17%
2.	General idea on precautionary measurements	45%	60%	45%
3.	Effectiveness on present lightning protection towers	55%	89%	76%
4.	Trust on the protection system	45%	90%	67%
5.	Further improvement on the present system	37%	65%	48%

Table 2

8. Conclusions

It is clearly shown that the earth conductivity enhancement material used for earthing improves the earth resistance value irrespective of the type. Natural material such as rice hulls and cocopeat also can be used as earth conductivity enhancement material as they have the characteristic of high absorption of moisture content. Normally earth resistance of an earth electrode should be kept below 10 ohms. This is not an individual protection solution therefore with this type of common lightning protection solution tower sharing mechanism an acceptable results can be obtained in a mountainous area. By adding more earth electrodes and earth enhancement material this value can be further reduced. Comparing the three material used, it is noticed that coco peat has behaved as good earth conductivity (or better mention, moisture storage) material. Paddy dust or rice hulls also can be used in earth pits. The cost of a lightning protection tower can be further reduced by introducing coco peat or rice hulls. After installation and educating the public, the knowledge on lightning has been improved considerably in the village.

9. References

1. K.R. Abhayasingha, Lightning Hazards: Impacts & Responses of the Public, 18th International Lightning Detection Conference, 7-9 June 2004 (ILDC 2004) Helsinki, Finland.
2. Lightning Protection Standards SLSI 1261.
3. ANSI/NFPA 70-1991, National Electric Code.
4. ANSI/IEEE Std 142-1982, Green Book, Section 4.1.
5. Martin D. Conroy and Paul G. Richard, Deep Earth Grounding Vs Shallow Earth Grounding.