

Welcome

Vaisala Humidity 101 – Best Practices in Humidity Measurement



Bruce McDuffee
Vaisala Humidity
Instructor



Yumi Shakya
Vaisala Application
Engineer

VAISALA

Humidity 101

\ webinar series

First - you must understand the parameter you want to measure.

VAISALA

Agenda

1. Discuss the 7 Points as defined by NPL
2. Questions

The 7 Points

1. Choose the correct instrument
2. Follow the manufacturer's instructions
3. Ensure a proper calibration
4. Keep records
5. 'Spot-check' performance
6. Be knowledgeable about the parameter
7. Be aware of potential external factors

Where do the 7 points come from?

National Physical Laboratory (NPL)

The Institute of Measurement and Control

London

www.npl.co.uk

'A Guide to the Measurement of Humidity'

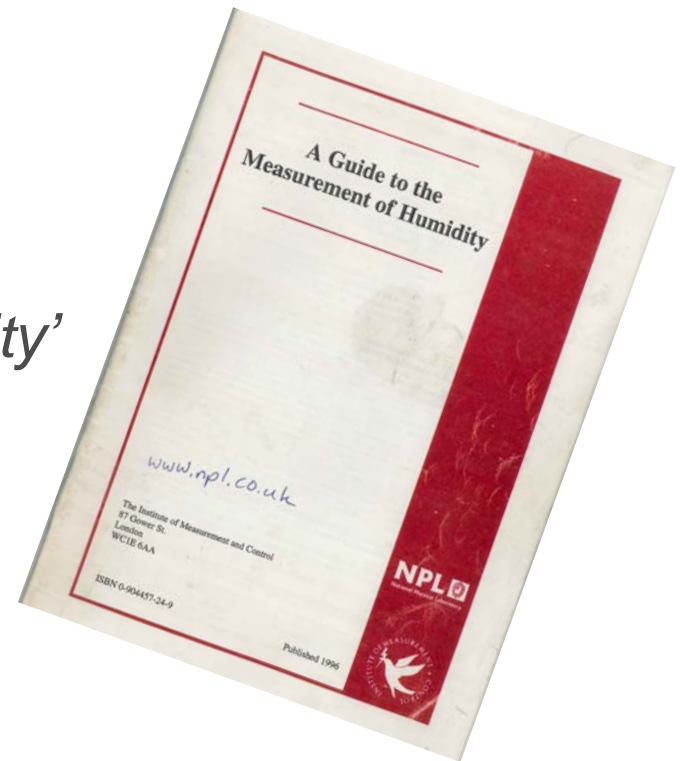

1. Choose the correct instrument

Be aware of what the sensor is measuring and how the environment could affect it.



1. Choose the correct instrument

Condensation Hygrometer

Good Measurement can be

- affected by temperature differences? **NO**
- affected by pressure differences? **YES**
- affected by changes in water vapor content? **YES**

Note: Be aware of the possibility of condensation in a sample line

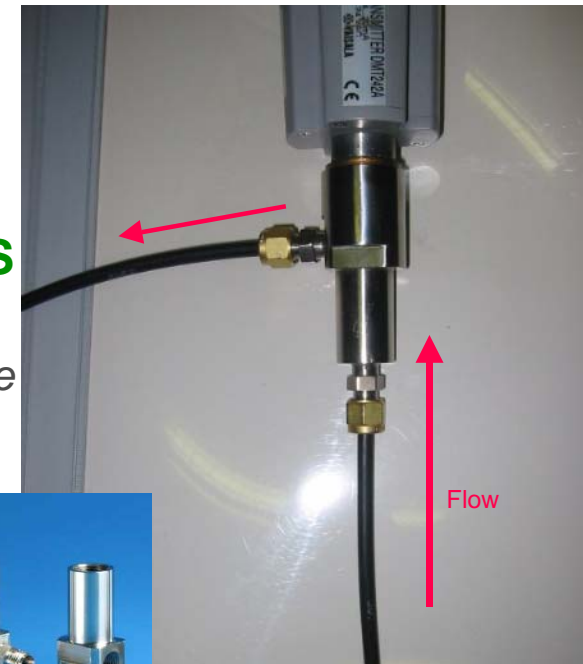

1. Choose the correct instrument

Psychrometer

- Measures wet bulb and dry bulb temperatures
- Good measurement depends upon
 - Accuracy of the thermometers
 - Consistency in operation
 - Contamination of water/sock
 - Accuracy of the conversion
 - Volume of the air sample



1. Choose the correct instrument

Aluminum Oxide

- Measures water vapor partial pressure
- Good measurement depends upon
 - Keeping the sensor dry
 - Regular calibration
 - Accurate pressure measurement
 - Clean air sample
 - Generous stabilization time (up to 24 hours)

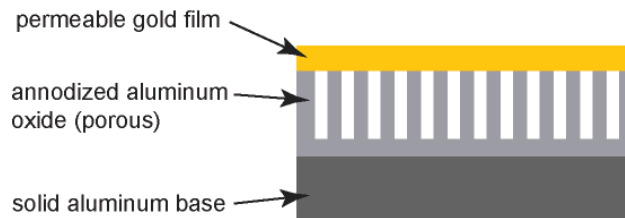

1. Choose the correct instrument

Polymer capacitor

- Measures relative humidity
- Good measurement depends upon
 - **temperature – temperature – temperature**

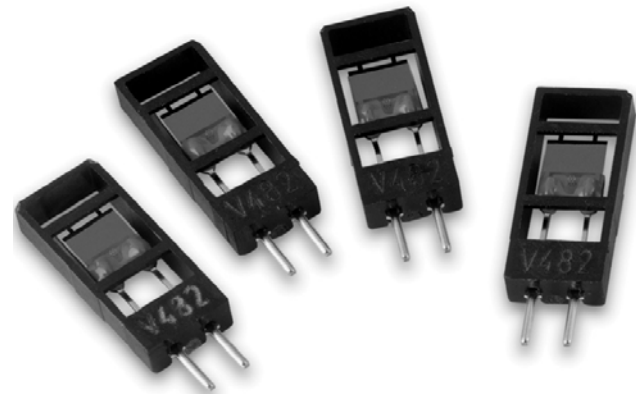
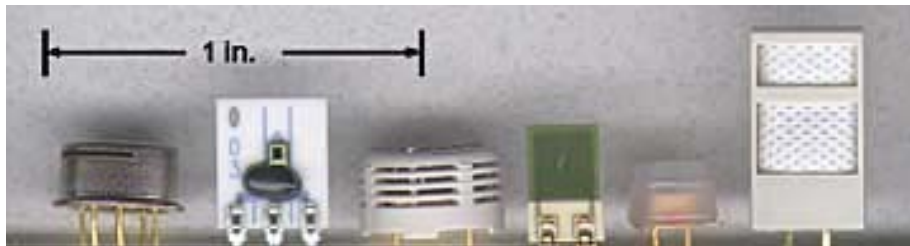

2. Follow the Manufacturers' Instructions

- Read the Manual
- Use the Technical Support
- Use the Application Engineers
- Use the Sales Engineers

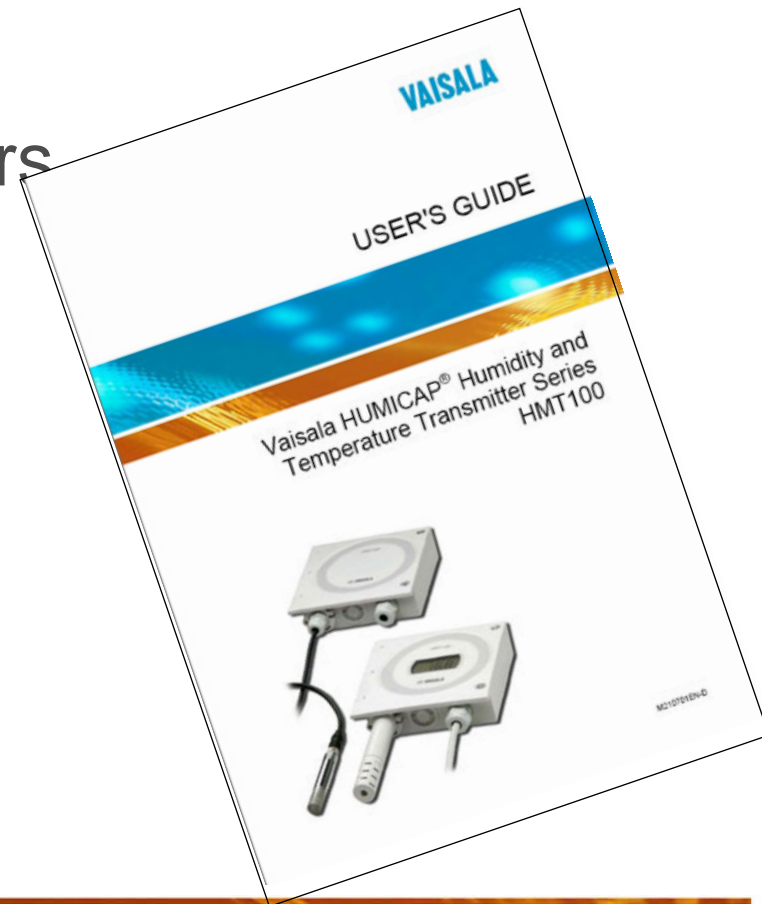

2. Follow the Manufacturers' Instructions

Proper installation

- Must be mounted in area where air or gas is representative of the process or environment
- Air should flow around or past the sensor
 - good air flow is an advantage; it ensures that the probe and ambient air are at the same temperature & ensures that the measurement is representative of the space
- Avoid anomalous sources of heat or cold; i.e. sunlight

2. Follow the Manufacturers' Instructions

Probe installation

- horizontal is preferred; bend in the cable
- allow for temperature and pressure fittings
- use insulation and sample line heating
- ensure representative sample of air with flow preferred

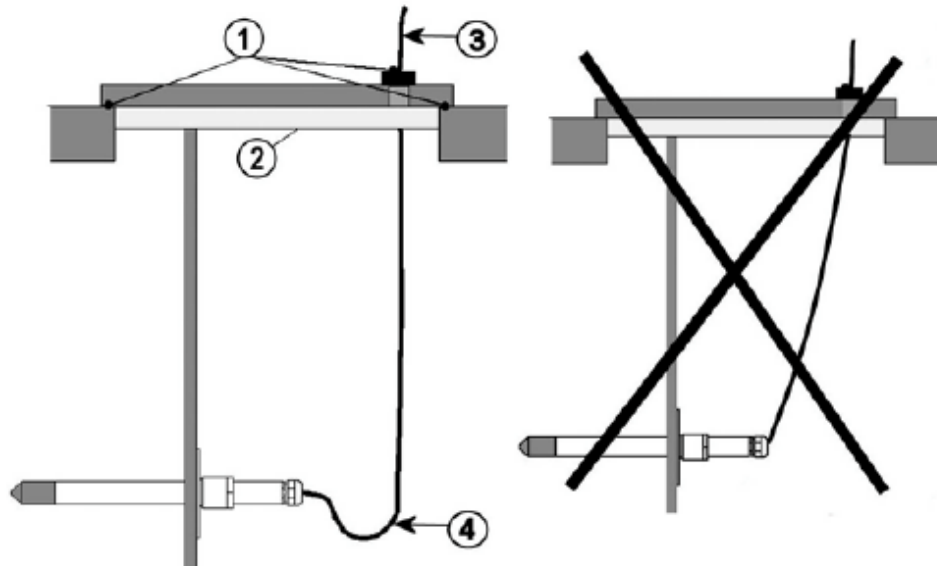

0507-024

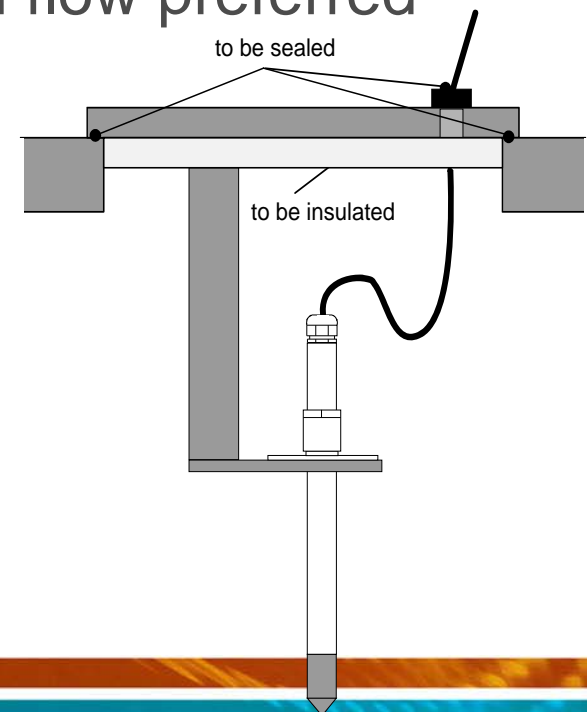

3. Ensure a proper calibration

- Is the calibration within the recommended interval?
- Is it traceable?
- Is there a valid certificate available?
- Does the calibration comply with your requirements?

4. Keep records

- Record of calibration
- Record of adjustments
- Record of repairs
- Out of tolerance results
- Record of any damage to the instrument

5. Spot-check performance

- Check at intervals between calibrations
- Check before and after any event that may stress the instrument
 - Transportation
 - Packaging or shipping
- Check against one or, even better, two other instruments

6. Be knowledgeable about the parameter

a x ppm T_d T_w h RH

- Know what parameter you are measuring and be aware of the potential effects of the environment around the point of measure.
 - sensor type
 - gas effect
 - CO₂, pure hydrogen, other high concentrations of gas
 - temperature & pressure effect
 - is output parameter measured or calculated

6. Be knowledgeable about the parameter

Polymer & organic sensors measure RH

$$\%RH = 100 \times \frac{P_w}{P_{ws}(t)}$$

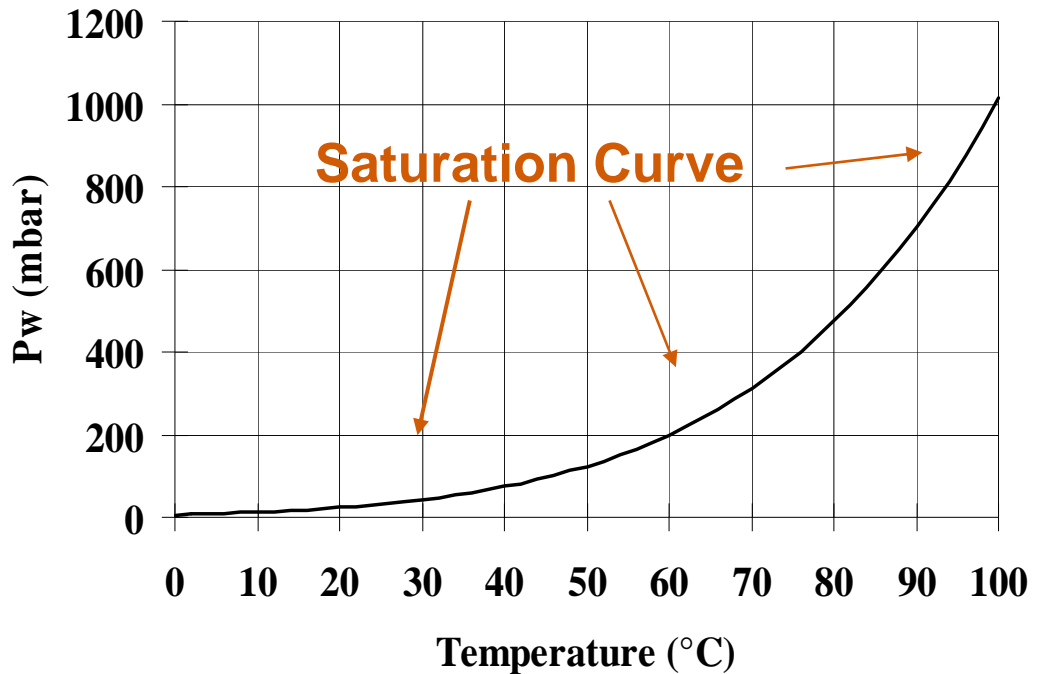

temperature – temperature - temperature - temperature

Note: at 20°C a temperature difference of just 1°C may add 3% error to the RH measurement

6. Be knowledgeable about the parameter

Allow adequate time for equilibration

- 'Adequate time' varies depending on the difference in conditions and the sensor technology
 - Temperature
 - Vapor pressure
 - Sensor type

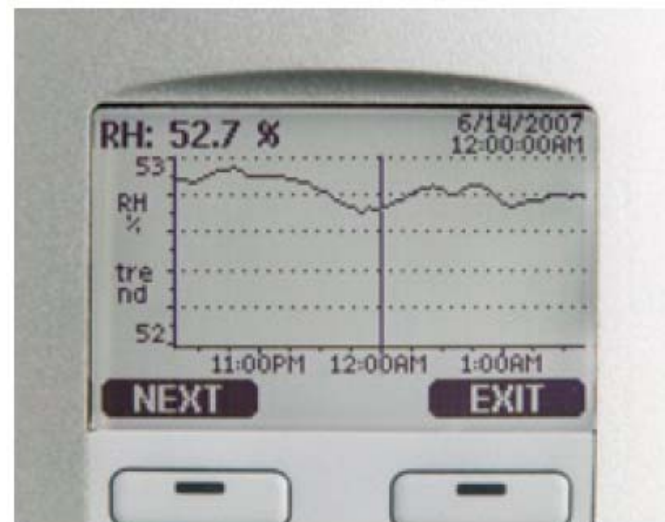

6. Be knowledgeable about the parameter

How is the parameter determined?

- Is it measured directly or calculated?
- Does the calculation require pressure input?
- Is the calculation dependent on temperature?
- Dewpoint or Frostpoint? (for example)
- Pressure dewpoint or atmospheric dewpoint?
- Mixing ratio or ppm calculation require actual pressure input (for example)

$$Td_{pres} = \frac{T_n}{\left[\frac{m}{10 \log \left(\frac{P_{W_{pres}}}{A} \right)^{-1}} \right]}$$

$X = B \cdot P_w / (P_{tot} - P_w)$
(8)

$$PPM_v = \frac{P_w}{(P_{tot} - P_w)} 10^6$$

7. Be aware of potential external factors

- Do not introduce external factors that will affect the measurement
 - direct sunlight
 - body heat and humidity
 - non-representative sources of heat
 - stagnant and/or non representative air samples
 - temperature leakage

7. Be aware of potential external factors

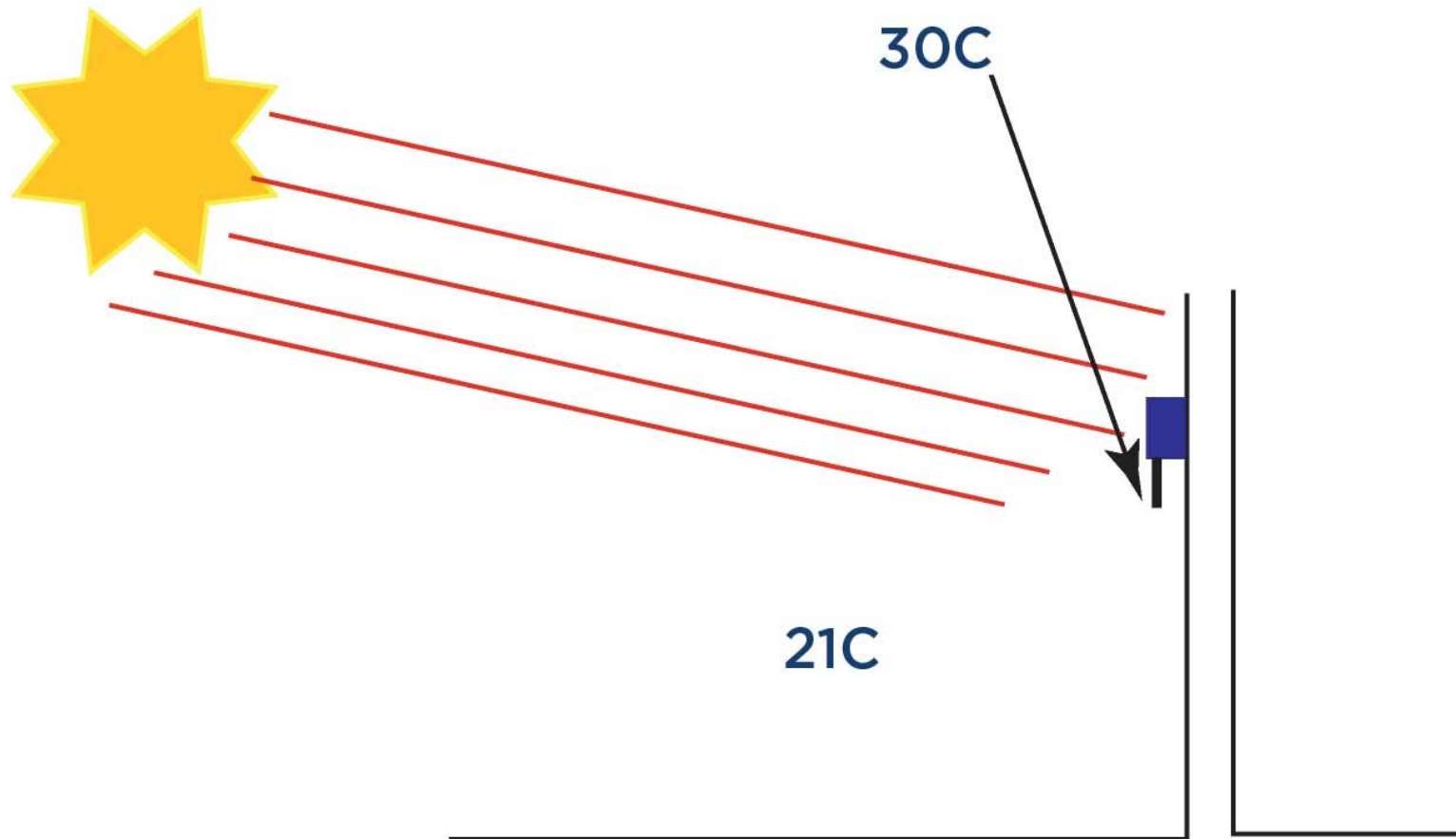

7. Be aware of potential external factors

Anomalous Sources of Heat or Cold

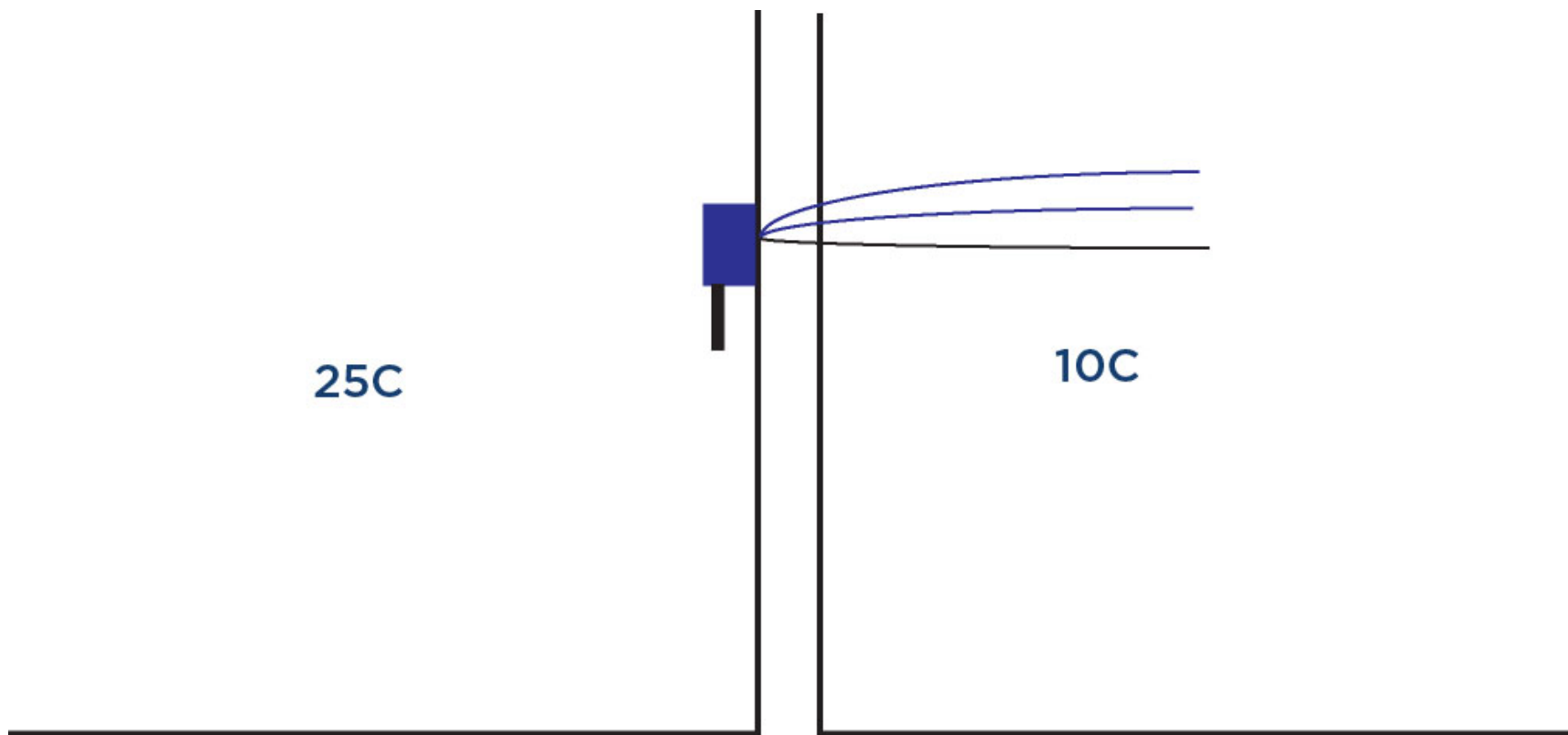

7. Be aware of potential external factors

Temperature Leakage

- if the temperature of the process is considerably higher than that of the environment, the whole probe and preferably a part of the cable must be in the process

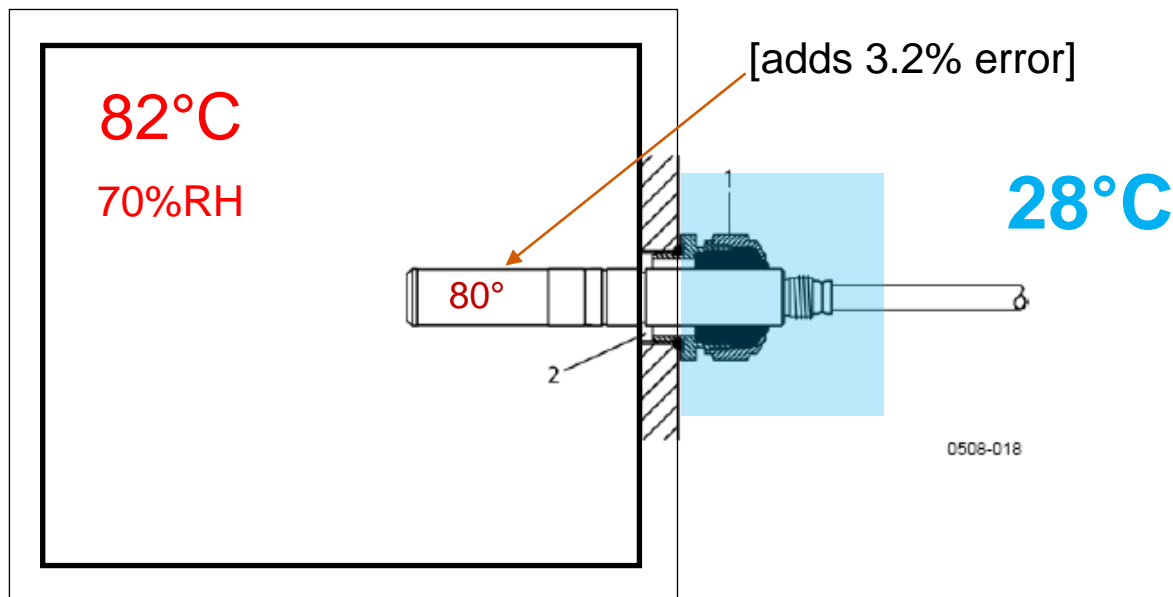

7. Be aware of potential external factors

Temperature leakage

- Less critical, but enough difference where you want the whole portion of the metal probe inside the process and the cable sealed.

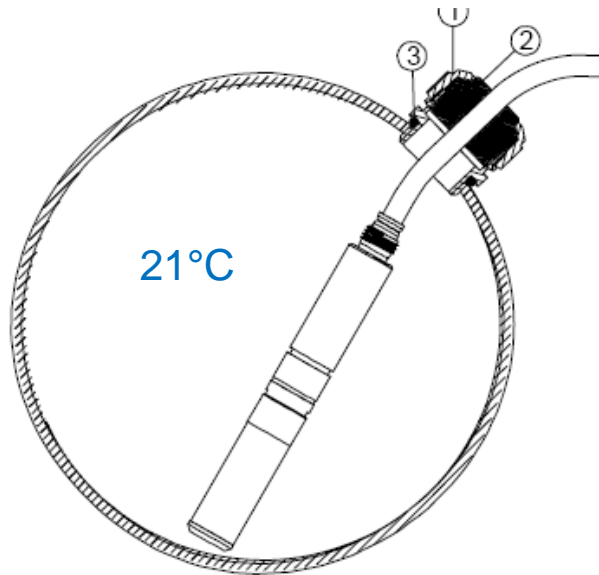

28°C

0508

7. Be aware of potential external factors

Temperature leakage

- Very large differences require heavy insulation

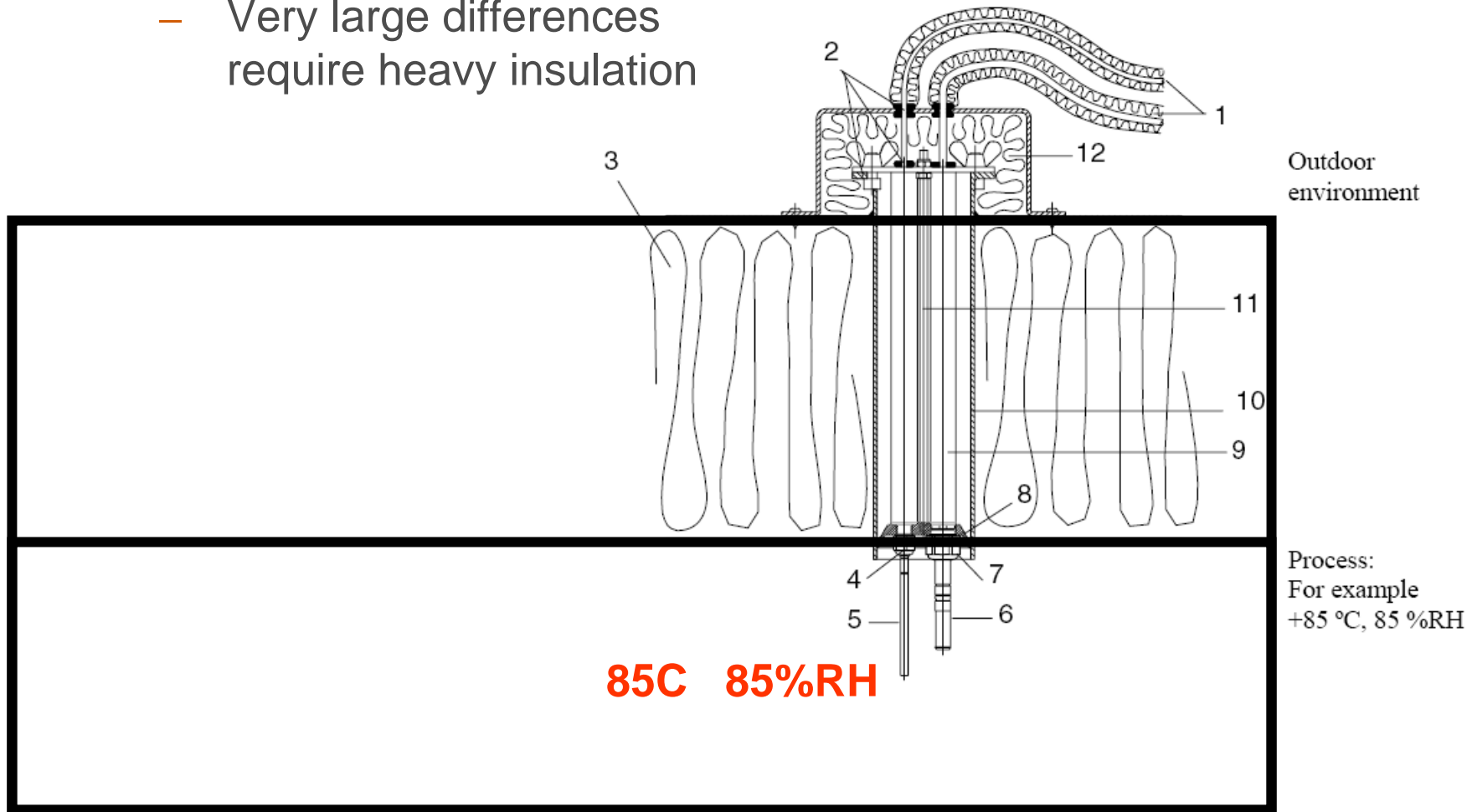

7. Be aware of potential external factors

Temperature

- From room to high temperature high humidity chamber

Testing chamber

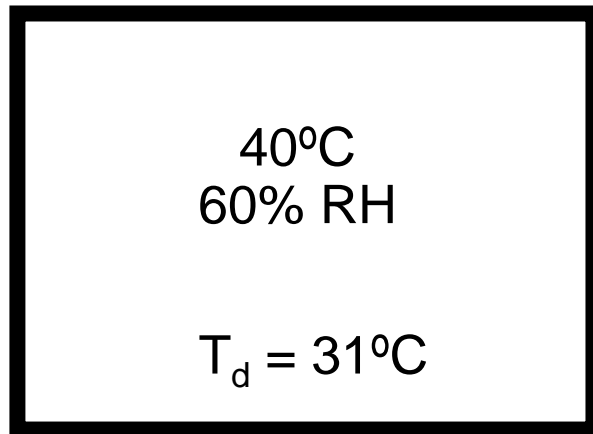

20°C
ambient
temp



What is the dewpoint?

You must **PRE-HEAT** the probe!!

7. Be aware of potential external factors

Water Vapor Pressure

Testing chamber

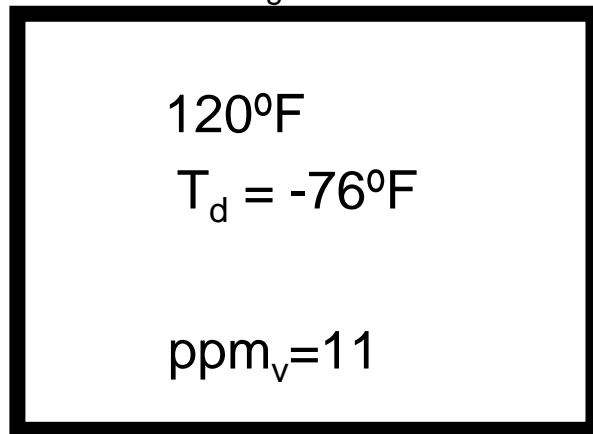

80°F @ 35%RH

What is T_d ? 50F

What is ppm_v ? 12,000 ppm_v

What is the ppm_v ?

7. Be aware of potential external factors

Water Vapor Pressure

- ensure a tight seal
- be aware of the cable feed through (is it vapor tight)
- positive pressure can help prevent ingress

Best Practices Summary

■ 7 Points

1. Choose the correct instrument
2. Follow the manufacturers instructions
3. Ensure a proper calibration
4. Keep records
5. 'Spot-check' performance
6. Be knowledgeable about the parameter
7. Be aware of potential external factors

Summary of Questions from the Audience

Vaisala Humidity Measurement Resources

- On-line Humidity Calculator www.vaisala.com/humiditycalculator
- Slide Rule Calculator to order – <http://forms.vaisala.com/forms/RequestSlideRule>
- Psychrometric Chart - <http://forms.vaisala.com/forms/RequestPsychChart>
- Humidity Conversion Formulas - http://forms.vaisala.com/forms/humidity_conversion

For expert assistance with your humidity measurement:

North America:

Email: instruments@vaisala.com

Direct telephone: 800-408-9454

Web: www.vaisala.com/instruments

Global – www.vaisala.com/contact

Next Webinar – Calibration of the Humidity Instrument

Thursday, October 14th , 10:00AM PDT

Full Webinar Schedule info & registration:

www.vaisala.com/webinars

Everyone who registered for previous webinar will get the invitation for all subsequent webinars.

You will receive a follow up email with all of the resource links & link to recording.

Live Humidity Seminars

Raleigh – September 21st

Boston – October 27th & 28th

Los Angeles – December 1st

<http://vaisala.com/seminars>

Thank you!

This concludes the webinar.

Follow-up email will arrive shortly with the resource links & further contact information.

Link to the recorded version will follow.