

## QUICK REFERENCE GUIDE

### Vaisala SPECTRACAP® Oxygen Transmitter OMT364



OMT364 Oxygen Transmitter is approved for Class I, Division 2, Groups A, B, C and D. Sensor for Class I, Division 1 and 2, Groups A, B, C and D hazardous indoor and outdoor locations with an enclosure rating IP66. Temperature class T4.

**CAUTION** OMT364 is a Class 1 laser product. Normal handling and operation of the device is eye-safe because laser radiation is collimated and maintained inside the probe. No laser radiation is emitted outside the probe. Do not place reflective surfaces directly into the probe when the transmitter is in operation.



## IN-LINE INSTALLATION

The maximum diameter of the OMT364 flange adapter is  $\varnothing$  97 mm. It has been chosen to suit to the center of a DIN 2572/B flange (mounted with M16 hex bolts). The smallest possible ANSI flange is ANSI 150 2.5" (mounted with 3/4" hex bolts).

Installation with probe pointing upwards prohibited. Installation allowed only with probe horizontal or at a maximum of 45° downward angle.

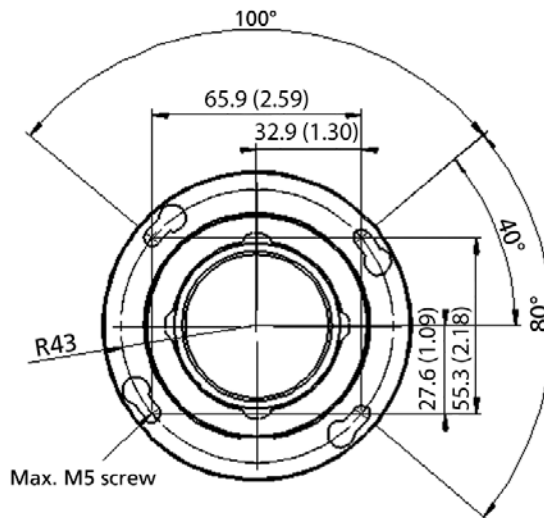
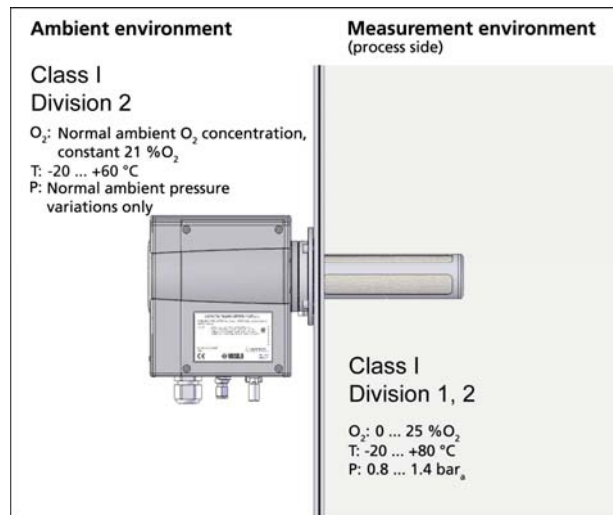

Figure 1 Flange Adapter Dimensions

## AMBIENT MEASUREMENT

1. Attach the wall mounting bracket to the desired location.
2. Pre-fix the two outer M6 screws to the threads at the bottom of the transmitter
3. Attach the two inner screws as you place the transmitter on the wall mounting bracket.
4. Finish the installation by tightening all four screws.

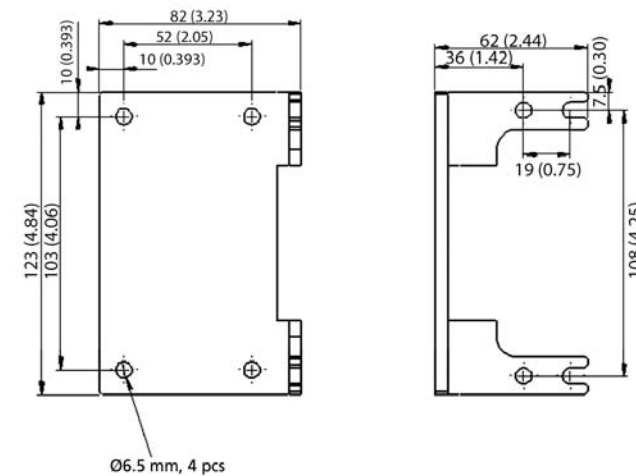
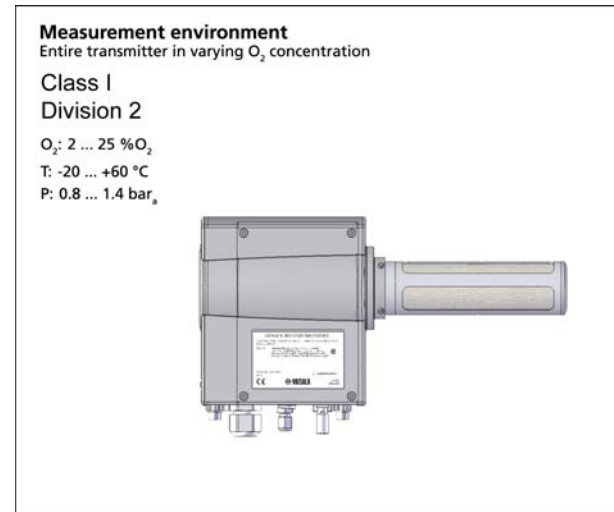
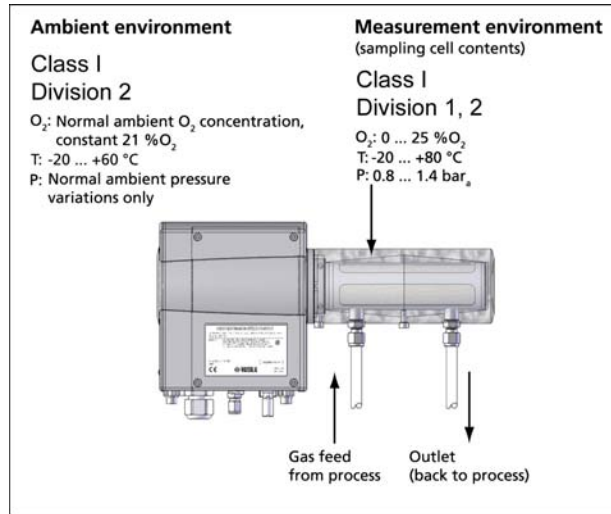

Figure 2 Wall Mounting Bracket Dimensions

## SAMPLE CELL INSTALLATION



## WIRING

Open the front cover (**never open the side cover**) with the 3 mm Allen key provided in the packing box to access the terminals.

In order to fulfill EMC requirements, the transmitter should be connected to earth using the external terminal provided.

### Installation notes:

Vin = 11 ... 36 VDC, Pmax = 6 VA

For screw terminal connections use conductor AWG 20-16.

Always connect unpowered wires to transmitter to avoid sparks on hazardous area. Make sure that Power ON switch under yellow protective cover is in ON position before making any wiring.

Install using Division 2 wiring methods as specified by the NEC or CEC, as applicable.

**WARNING** Explosion hazard. Do not connect or disconnect equipment when a flammable or combustible atmosphere is present.

## LOCAL INTERFACE LAYOUT

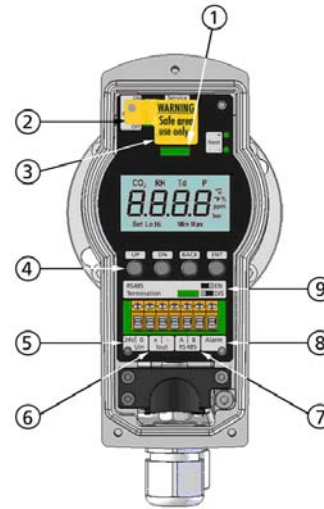

Figure 3 OMT364 Local Interface

- 1 = LED (red for startup or error, green for normal operation)
- 2 = Power ON/OFF switch (under the yellow tag)
- 3 = Service Port (RS-232) (under the yellow tag)
- 4 = Local interface keypad pushbuttons
- 5 = Supply voltage terminals
- 6 = Current output terminals
- 7 = RS-485 terminals
- 8 = Relay contact terminal
- 9 = RS-485 line termination jumper

## STARTUP AND SELF-TEST SEQUENCE

Make sure that the power switch (located below the yellow warning tag) is in the ON position, and attach the front cover securely. Switch on the supply voltage.

After the self-test and warm-up are complete, oxygen measurement starts. The entire start-up sequence takes approximately 2.5 minutes.

Note that the transmitter may output some errors to the serial line immediately after the self-test is over. These errors are expected. No errors should remain active.

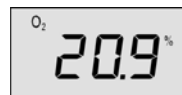

Figure 4 Oxygen Measurement Reading

If the self-test finds any errors, the error code is shown on the display. Refer to the User's Guide for the list of error codes.



Figure 5 Error Code on Display

## USING THE DISPLAY/KEYPAD

The OMT364 has a local interface that can be accessed by opening the front cover. The interface allows you to, for example, view measurement information, enter compensation parameters, perform calibration, and change the analog output scaling. Refer to the User's Guide for a full description.

To enter the menu, press the **Up** or **Dn** key. Use the **Up** and **Dn** keys to scroll through the menu, and activate functions by pressing the **Ent** key. To interrupt a function, use the **Back** key.

## USING THE SERVICE PORT

**WARNING** Use the service port in safe area only.

The transmitter has an RS232C serial port for service functions. Refer to the User's Guide for connection cable options. If you need to reconfigure device alarm level(s), Customer Interface or other settings, the Service Interface provides a wider range of options than the keypad and display functions.

Default serial communication settings are: Baud rate 19200, 8 data bits, no parity, 1 stop bit.

## SERIAL COMMANDS

The list below provides some useful serial commands. Refer to the User's Guide for a full command list.

- ? Shows information about the device
- CO2 Shows/sets CO2 for compensation
- COXY1 Perform one-point adjustment
- COXY2 Perform two-point adjustment
- ERRS Shows detected errors
- H2O Shows/sets H2O for compensation
- HELP Lists commands
- PRES Shows/sets pressure for compensation
- R Starts continuous output
- S Stops continuous output
- SEND Sends measurement results
- SIL Measures signal level
- VERS Shows product name and software version