

# WHP25 Power Supply



## DESCRIPTION

The WHP25 is a compact size Mains Power Supply Unit intended for outdoor use.

The nominal input power of 230 VAC can be changed by jumpers between 100 VAC to 245 VAC ( $\pm 10\%$ ). There are two power outputs, namely 24.0 VDC (max 5.2 A) and 38.0 VAC (max 0.9 A).

The WHP25 Outdoor Power Supply is capable of delivering power to the whole WA25 Heated Wind Sensor System and additionally, for example, to the RG13H Heated Rain Gauge.

The WHP25 has a water-proof housing made from cast aluminium, mountable to a  $\varnothing 100$  mm standard pole mast with a mounting hardware included in the delivery. The unit can also be mounted to the standard DKP11 Stacked Mast using the 10388DK mounting kit.

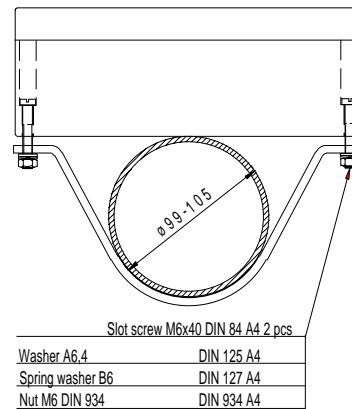
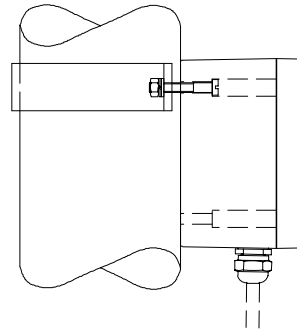

- Linear 160 W Mains Power Supply
- Compact size with mast mounting
- Outdoor use with IP65 (Nema 4) housing

## INSTALLATION

Figure 1 illustrates mounting of the WHP25 to a  $\varnothing 100$  mm pole mast, with the standard mounting clamp. For installation, follow the procedure below:

- 1 Remove the four screws attaching the cover of the WHP25 unit. Remove the cover.
- 2 Attach the unit to the mast at suitable height with the two M6 screws and the mounting clamp.
- 3 With the local mains voltage level other than 230 VAC, make proper reselection with the jumpers at X2 and X3 (under the protective cover). Observe the instructions and warnings in the instruction label inside the unit. Refer to Figure 2.
- 4 With the mains voltage disconnected enter the mains cable through the leftmost cable gland and do the input wiring to the X1 (spring loaded terminals) and Earth (crimp & screw). Tighten the input cable gland.
- 5 Enter the output power cable(s) through the rightmost cable gland(s). For better protection against RF interference, follow the earthing instructions of the cable shield in Fig. 4. Assure that no shield mesh gets on the circuit board.
- 6 Do the output wiring to the X4 removable screw terminal block (refer to the instruction label). Tighten the output cable gland(s).
- 7 Carefully reattach the enclosure cover with the four screws.

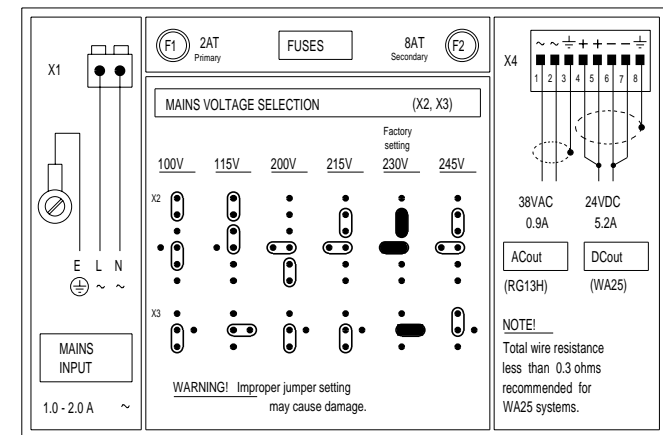

Figure 2. WHP25 wiring instructions (refer also to label inside the enclosure)



## TECHNICAL DATA

Input operating power	
Nominal	230 VAC $\pm 10\%$ , 50/60 Hz, 1.0 A max.
Optional selections	100/115/200/215/245 VAC ( $\pm 10\%$ )
Output power	
DC output	24.0 $\pm 2.5$ VDC, 5.2 A (max.) (X4/4, 5 – 6, 7)
AC output	38.0 $\pm 3.0$ VAC, 0.9 A (max.) (X4/1 – 2)
Fuses	
Primary	2 AT replaceable fuse, 5 $\times$ 20 mm (F1)
24 V output	8 AT replaceable fuse, 5 $\times$ 20 mm (F2)
38 V output	1.8 Amp solid state fuse (R3)
Electrical connections	
Cable glands (3)	One for input, two for outputs Cable $\varnothing$ 7 – 10 mm
Input wiring (L, N)	Spring loaded terminals (X1) 1.5 mm <sup>2</sup> max. wire dimension
Input wiring (E)	Crimp connector, 2.5 mm <sup>2</sup> max.
Output wiring (24 V, 38 V)	8-pin removable screw terminal connector, 2.5 mm <sup>2</sup> max.
Operating temperature	- 60 ... +55 °C
Storage temperature	- 60 ... +70 °C
Humidity	Non-condensing
Material	
Housing	Cast aluminium, painted grey
Mounting clamp	AlMgSi, grey anodized
Ingress protection	IP65 (Nema 4)
Dimensions	
Unit	220 $\times$ 120 $\times$ 81 mm (w $\times$ h $\times$ d) (cable glands add 23 mm to height)
Mounting	To a $\varnothing$ 99 – 105 mm pole mast tube with standard mounting clamp
Weight	3.6 kg

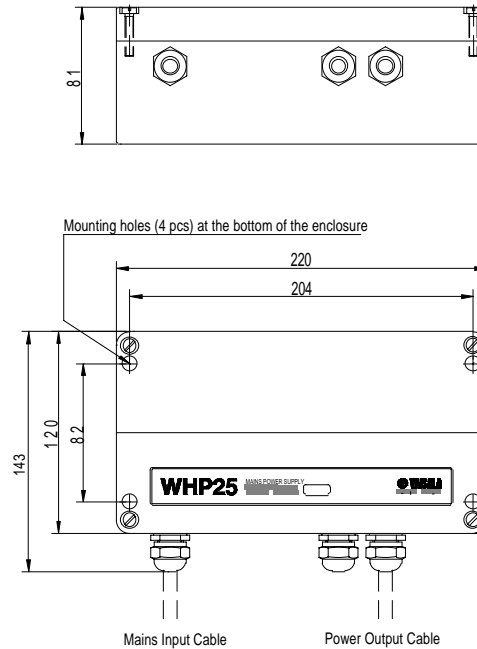

Figure 3. WHP25 dimensions

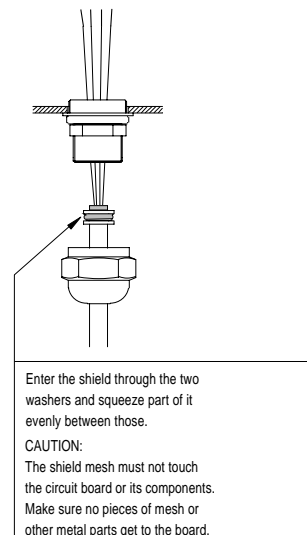

Figure 4. Earthing of power output cable shield

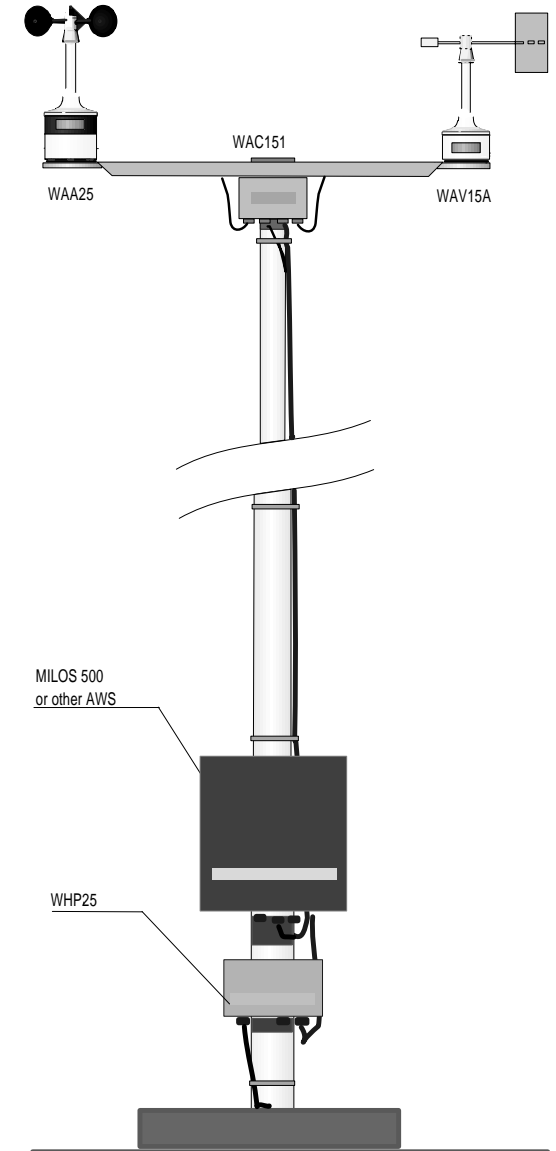

Figure 5. Typical installation with a Heated Wind Sensor System



Head Office:  
VAISALA Oy  
PL 26, FIN-00421 Helsinki  
FINLAND  
Phone (int.): (+358 0) 894 91  
Telefax: (+358 0) 894 9227  
Telex: 122832 vsala fi



ISO 9001