

QUICK REFERENCE GUIDE

Vaisala HUMICAP® Humidity Module HMM100



Download
the complete User's Guide from:
www.vaisala.com/HMM100



GENERAL

The HMM100 series humidity measurement modules are open frame modules intended for integration into environmental chambers. The modules provide a single analog output channel for relative humidity (RH) or dewpoint (T_d). See section Technical Data for more information.

NOTE All HMM100 series modules include automatic temperature compensation across the operating temperature range. No external temperature compensation should be applied to the output.

NOTE The measurement probe with cable is attached to the component board at Vaisala. Do not disconnect and reconnect the cable.

INSTALLATION

When selecting the mounting location for the probe, note the following:

- The probe should be entirely in the measurement environment, with sufficient distance to the outer walls of the chamber or duct. Air should flow freely around the probe.
- The probe location should represent well the environmental or process conditions, and it should be as clean as possible.

1. Attach the module securely using the mounting holes on the corners of the component board. Use the optional mounting bracket if needed. Be sure to provide an earth connection from the plated mounting hole. See Figure 1. Refer to the User's Guide for Vaisala order codes of accessories.
2. Install the probe in the location. Use the optional probe mounting flange or mounting clamp if needed. Insert enough cable to the same space with the probe in order to prevent heat conduction, and to allow the probe to be moved when calibrating.
3. Connect the wires to the screw terminals:
 - **2-wire output:** see Figure 2. Provide a 24 VDC supply voltage.
 - **3-wire output:** see Figure 3. Provide the required supply voltage according to the output type:
10 ... 35 VDC or 24 VAC for 0 ... 20 mA, 1 / 5 V
15 ... 35 VDC or 24 VAC for 0 ... 10 V
4. Verify the installation: power up the module and check the output reading.

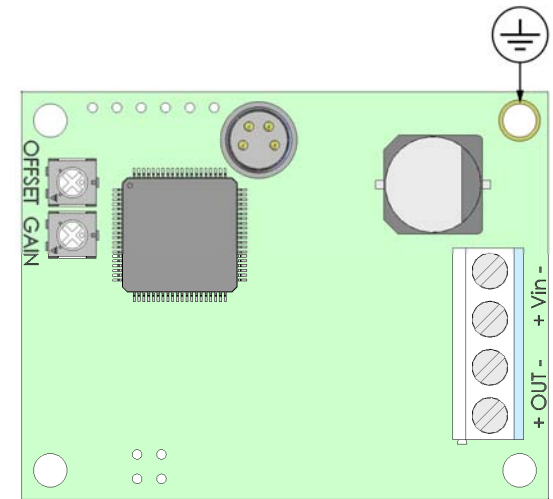

Figure 1 Component Board (3-wire version)

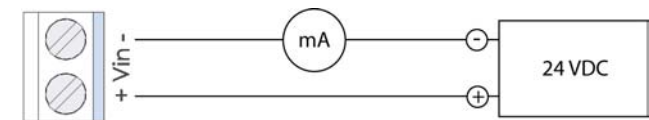

Figure 2 Wiring for 2-wire Output

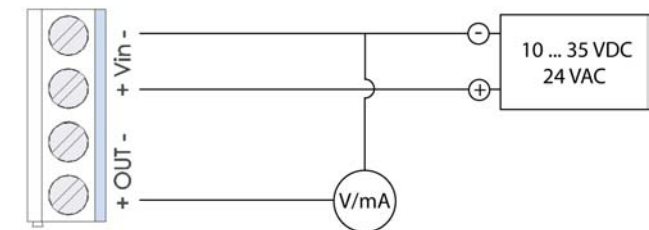

Figure 3 Wiring for 3-wire Output

When using the 3-wire output module, you may also connect a fourth wire to the "Out -" terminal. It is internally connected to the "Vin -" terminal. This will help reduce electrical interference, especially when using the 0 ... 1V output.

ADJUSTMENT USING TRIMMERS

HMM100 series modules have two trimmers mounted on the component board. These trimmers allow for easy adjustment of the **offset** and **gain** of the humidity measurement. The modules are shipped with the trimmers centered.

Turning the trimmer counter-clockwise will decrease the offset or gain, and turning clockwise will increase it. The adjustment range is $\pm 5\%$ for both offset and gain.

Offset correction requires a $< 50\%$ RH reference. Offset and gain correction requires additionally a $> 50\%$ RH reference, with over 30% RH difference between the two points.

NOTE The trimmers will only turn 135 degrees each way, less than half a rotation. Do not force the trimmer past the stopping point.



Figure 4 Trimmers for Offset and Gain

The procedure below provides an example adjustment of offset and gain using the saturated salt calibrator HMK15. It is assumed that the module is powered and you can measure the output reading.

- Note the current position of the trimmers.
- Insert the probe in the LiCl salt chamber of the humidity calibrator (11 %RH), and wait for 20 – 40 minutes for the reading to stabilize.
- If necessary, adjust the **offset trimmer** using a small Phillips-head screwdriver to achieve the output reading that corresponds to 11 %RH.
For 4 ... 20 mA output, the reading should be 5.76 mA.
For 0 ... 5 V output, the reading should be 0.55 V.
- Insert the probe in the NaCl salt chamber (75 %RH) and wait for the reading to stabilize.
- If necessary, adjust the **gain trimmer** to achieve the output reading that corresponds to 75 %RH.
For 4 ... 20 mA output, the reading should be 16 mA.
For 0 ... 5 V output, the reading should be 3.75 V.
- Optional: repeat steps 2 – 4 to check the adjustment result. If you want to undo the adjustment, return the trimmers to their original position.

TECHNICAL DATA

Property	Description / Value
Measured parameters Relative humidity Dewpoint	0 ... 100 %RH -20 ... +100 °C (-4 ... +212 °F) Td
Accuracy -20 ... +40 °C -40 ... -20 °C, +40 ... +180 °C	$\pm 2\%$ RH (0 ... 90 %RH) $\pm 3\%$ RH (0 ... 100 %RH) $\pm 2.5\%$ RH (0 ... 90 %RH) $\pm 3.5\%$ RH (0 ... 100 %RH)
Sensor	Vaisala HUMICAP® 180R
Outputs 2-wire 3-wire	4 ... 20 mA (loop powered) 0 ... 20 mA, 1 / 5 / 10 V
Supply voltage 2-wire 3-wire (0 ... 20 mA, 1 / 5 V) 3-wire (0 ... 10 V)	24 VDC 10 ... 35 VDC or 24 VAC 15 ... 35 VDC or 24 VAC
Input current	6 mA
Connections	Screw terminals, 0.5 ... 1.5 mm ² 4-pin M8 connector for service use
Probe types and cable lengths	Plastic, 0.6 m cable Plastic, 1.55 m cable Plastic, 2.9 m cable Stainless steel, 1.55 m cable Stainless steel, 2.9 m cable
Sensor protection options	Plastic grid filter Membrane filter Porous PTFE filter Stainless steel sintered filter
Operating temperature range Component board Probe (both types) Plastic grid and membrane filter PTFE and stainless steel filter	-5 ... +55 °C (+23 ... +131 °F) -70 ... +180 °C (-94 ... +356 °F) -20 ... +80 °C (-4 ... +176 °F) -70 ... +180 °C (-94 ... +356 °F)

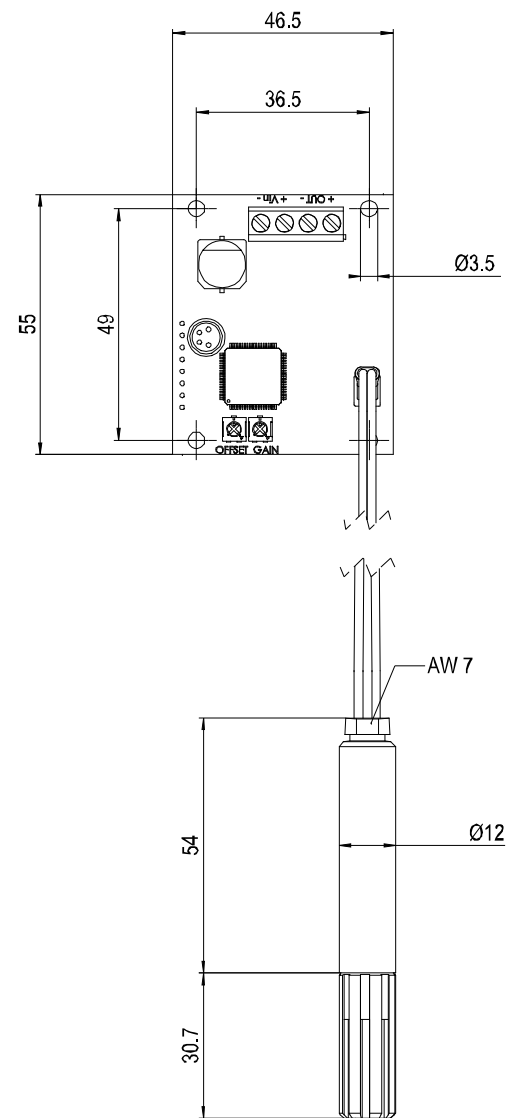

Figure 5 Dimensions in mm