

INTRODUCTION

Vaisala's GMM220 transmitter modules are versatile instruments for measuring CO₂ in industrial applications. The CARBOCAP[®] sensor is silicon based and its operation is based on the NDIR Single-Beam Dual-Wavelength principle. The modules can be configured for different CO₂ measurement ranges and analog output ranges.

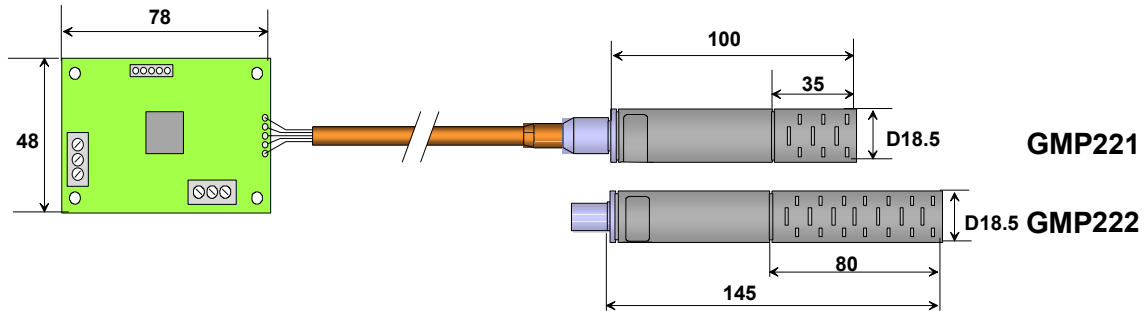

Figure 1. Dimensions of the Probes and Component Board of the GMM220 Series (in mm).

The GMM220 module consists of a component board, cable and a CO₂ probe. The shorter probe model (GMP221) is for higher and the longer model (GMP222) for lower CO₂ concentrations. A waterproof connector connects the probe to the cable. The probe also features a non-volatile memory for storing the calibration parameters. This enables true interchangeability of the probes and forms a good basis for easy field calibration.

MOUNTING

For power supply and analog outputs, the board is available either with pinheaders on bottom side or with screw terminals on top side; serial interface has always a pinheader.

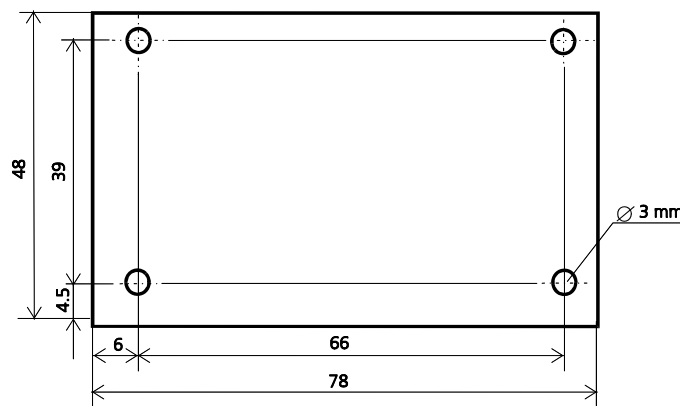

Figure 2 Dimensions of the Component Board (in mm)

If the board has pinheaders, mount it by soldering or plugging it into host board's female connectors.

ELECTRICAL CONNECTIONS

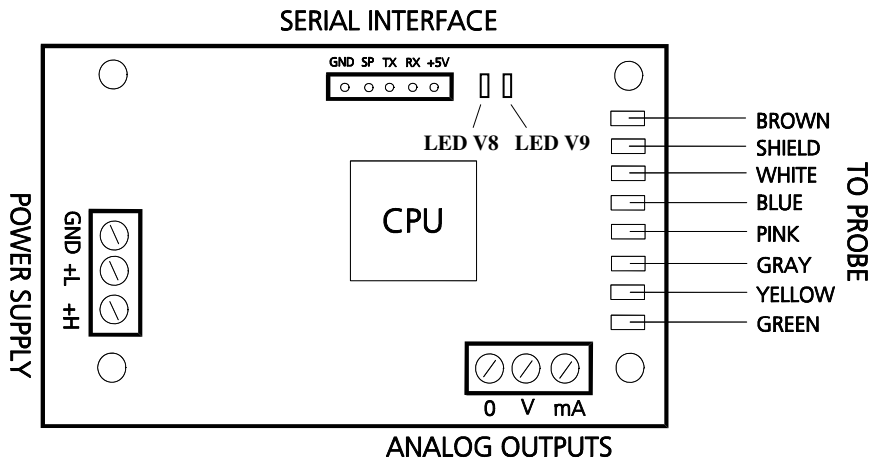

Figure 3. Electrical Connections

Power supply: Two supply voltage alternatives:
+L 12 volt supply input (11 VDC - 20 VDC)
+H 24 volt supply input (18 VDC - 30 VDC)
GND common ground for power supply
 Average current consumption is 100 mA (+ current output, max. 20 mA)

Analog outputs:
0 common for both analog outputs
V voltage output (default 0-1 V, on request 0-2 V, 0-2.5 V or 0-5V)
mA current output (default 4/20 mA, on request 0-20 mA)

Serial interface:
 The interface is a 5 Volt (TTL) level full duplex serial port.

GND signal ground (same potential as the supply GND)
TX data transmitted by the CO₂ module (low state corresponding mark)
RX data received by the CO₂ module (low state corresponding mark)

Leave other serial interface pins unconnected.

Probe wires: If the CO₂ module is ordered with a separate probe cable, solder the wires to the component board according to colors shown in Figure 3.

LEDS: Normal operation: Led V8 (red) is not lit and Led V9 (green) is blinking. Error state: Led V8 (red) is blinking and Led V9 (green) is blinking, no readings. In error state, check first that the probe is properly connected. In case of constant error, please contact Vaisala Service Centers.

SERIAL INTERFACE PROTOCOL

The transmitter is connected to a computer with the optional serial COM adapter (19040GM). A suitable terminal program such as WINDOWS[®] Hyper Terminal is needed for the communication.

Port settings:
 Baud rate 9600, data bits: 8, stop bits :1, parity: none, flow control: none

COMMANDS

The last character in the GMM220 reply is a prompt >.

Single CO₂ measurement output

DISP option <cr>

Options: 2 = concentration in ppm, 4 = concentration in %

For example:

```
>DISP 2<cr>           the command (bold)
6543.2 <cr><lf>       response from the GMM220
>                     prompt sent by the GMM220
```

Continuous CO₂ measurement output

MF_MODE option <cr>

Options: 0 = no output, 2 = output concentration in ppm, 4 = output concentration in %

For example:

```
>MF_MODE 4<cr>       the command (bold)
5.625<cr><lf>        response from the GMM220
5.625<cr><lf>
5.625<cr><lf>
```

To stop continuous outputting, give command: **MF_MODE 0<cr>** or **<ctrl+C>**

Pressure compensation (if altitude differs from sea level (default), make pressure compensation)

MF_PRESSURE xxxx <cr>

where: xxxx = pressure in hPa.

Example of setting desired pressure:

```
>MF_PRESSURE 900
MF_PRESSURE=900
>
```

To save the setting, give command: **MAIN_SAVE F**

Altitude m (ft)	Atmospheric pressure hPa (psi)
0 (sea level)	1013 hPa (14.69 psi)
500 m (1640 ft)	954 hPa (13.84 psi)
1000 m (3281 ft)	899 hPa (13.04 psi)
1500 m (4921 ft)	845 hPa (12.26 psi)
2000 m (6562 ft)	795 hPa (11.53 psi)
2500 m (8202 ft)	747 hPa (10.83 psi)
3000 m (9843 ft)	701 hPa (10.17 psi)

Temperature setting

MF_TEMP xxx <cr>

where: xxx = ambient temperature (°C) x 10.

Example of setting desired temperature (25 °C):

```
>MF_TEMP 250
MF_TEMP=250
>
```

To save the setting, give command: **MAIN_SAVE F**

TECHNICAL DATA

Measuring ranges

GMM221 0 ... 2%, 0 ... 3%, 0 ... 5%, 0 ... 10%, 0 ... 20% CO₂

GMM222 0 ... 2000 ppm, 0 ... 3000 ppm, 0 ... 5000 ppm,
0 ... 7000 ppm, 0 ... 10 000 ppm

Accuracy at 25°C against certified factory references

GMM221 ±[1.5 % of range + 2 % of reading]

GMM222 ±[1.5 % of range + 2 % of reading]

(including repeatability and calibration uncertainty)

Nonlinearity ± 0.5 % FS

Temperature dependence

of output (typically) -0.1 %FS / °C¹⁾

Pressure dependence (typic.) +0.15 of reading/hPa²⁾

¹⁾When temperature rises, the output decreases, default 25 °C (77 °F).

²⁾When pressure rises, the output increases, default 1013 hPa (1 atm).

Long-term stability <±5 %FS / 2 years

Response time (63%) 20 seconds (GMM221)

30 seconds (GMM222)

Operating conditions

Operating temperature range -20...+60 °C

Humidity range

probe 0 ... 100 %RH (non-condensing)

mother board 0 ... 85 % RH (non-condensing)

General

Analogue outputs 0 ... 20 mA or 4 ... 20 mA and

0 ... 1 V or 0 ... 2 V, 0 ... 2.5 V, 0 ... 5 V

Resolution of analogue outputs 0.03 %FS

Recommended external load:

current output max. 200 Ω

voltage output min. 1kΩ

Power supply 11 ... 20 VDC or 18 ... 30 VDC

Serial output @ 5V level

Power consumption < 2.5 W

Warm-up time < 5 minutes

Probe cable length 0.6 m, 2 m, 6 m, 10 m

Mechanics

Probe:

housing material PC plastic

housing classification IP65/NEMA4

Weight:

GMM221(w/ 2m cable) max. 180 g

GMM222 (w/ 2m cable) max. 200 g

COMPLIANCE WITH THE EMC-STANDARDS

EN 61326-1:1997 + Am1:1998, Electrical equipment for measurement, control and laboratory use - EMC requirements- Generic environment.

Testing: CISPR16/22 class B, EN/IEC 61000-4-2, EN/IEC 61000-4-3, EN/IEC 61000-4-4, EN/IEC 61000-4-5, EN/IEC 61000-4-6.

GUARANTEE

Vaisala issues a guarantee for the material and workmanship of this product under normal operating conditions for one (1) year from the date of delivery.

Exceptional operating conditions, damage due to careless handling and misapplication will void the guarantee.

Accessories

Order code	Description
GMP221, GMP222	Spare probe
25378GMSP	Spare filter for GMP221
25879GMSP	Spare filter for GMP222
25245GM	Clips (2 pcs) for attaching the probe
GM45168SP	Protective sleeve for GMP221
GM45237SP	Protective sleeve for GMP221
26150GM	Field check adapter
GM45156	Mounting flange for the probe
19040GM	Serial COM adapter

VAISALA SERVICE CENTERS

NORTH AMERICAN SERVICE CENTER

Vaisala Inc., 100 Commerce Way, Woburn, MA 01801-1068, USA.

Phone: +1 781 933 4500, Fax +1 781 933 8029

Email: us-customersupport@vaisala.com

EUROPEAN SERVICE CENTER

Vaisala SSD Service, Vanha Nurmijärventie 21 FIN-01670 Vantaa, FINLAND.

Phone: +358 9 8949 2758, Fax +358 9 8949 2295

E-mail: ssdservice@vaisala.com

ASIAN SERVICE CENTER

Vaisala KK, 42 Kagurazaka 6-Chome, Shinjuku-Ku, Tokyo 162-0825, JAPAN.

Phone: +81 3 3266 9611, Fax +81 3 3266 9610