

# Weather Sensor FD12P

## *USER'S GUIDE*

M210296en-A  
May 2002



PUBLISHED BY

Vaisala Oyj  
P.O. Box 26  
FIN-00421 Helsinki  
Finland

Phone (int.): +358 9 8949 1  
Fax: +358 9 8949 2227

Visit our Internet pages at <http://www.vaisala.com/>

© Vaisala 2002

No part of this manual may be reproduced in any form or by any means, electronic or mechanical (including photocopying), nor may its contents be communicated to a third party without prior written permission of the copyright holder.

The contents are subject to change without prior notice.

Please observe that this manual does not create any legally binding obligations for Vaisala towards the customer or end user. All legally binding commitments and agreements are included exclusively in the applicable supply contract or Conditions of Sale.

---

# Table of Contents

## CHAPTER 1

<b>GENERAL INFORMATION .....</b>	<b>11</b>
<b>About This Manual.....</b>	<b>11</b>
Contents of This Manual.....	11
<b>Version Information.....</b>	<b>12</b>
<b>Related Manuals .....</b>	<b>12</b>
<b>Safety .....</b>	<b>12</b>
General Safety Considerations.....	12
Product Related Safety Precautions .....	13
Safety Summary.....	13
Ground the Equipment .....	13
Radio Frequency Interference Statement (USA) .....	15
ESD Protection .....	15
<b>Trademarks .....</b>	<b>16</b>
<b>Warranty .....</b>	<b>16</b>

## CHAPTER 2

<b>PRODUCT OVERVIEW .....</b>	<b>17</b>
<b>Introduction.....</b>	<b>17</b>
Hardware Structure .....	17
Sensing Elements .....	19
Electronics Enclosure.....	20
Structural Elements.....	20
Operating Principle .....	21
Using FD12P .....	22
<b>Equipment Nomenclature .....</b>	<b>23</b>
<b>Specifications .....</b>	<b>24</b>
Mechanical Specifications .....	24
Electrical Specifications.....	24
Optical Specifications .....	25
<b>Capabilities and Limitations.....</b>	<b>26</b>
Visibility Measurement Specifications .....	26
Weather Sensing Specifications.....	26
Environmental Specifications .....	27

## CHAPTER 3

<b>INSTALLATION .....</b>	<b>29</b>
<b>Organizing Installation.....</b>	<b>29</b>
<b>Location and Orientation .....</b>	<b>30</b>
<b>Grounding and Lightning Protection.....</b>	<b>32</b>
Equipment Grounding.....	32
Internal Grounding.....	34

Grounding for Testing Purposes.....	34
Grounding Remote Units and Communication Cable.....	34
<b>Cable Selection .....</b>	<b>35</b>
Line Power Cabling.....	35
Communication Cable.....	35
<b>Unloading and Unpacking.....</b>	<b>36</b>
Unpacking Procedure .....	36
Storage Information .....	36
<b>Installation Procedures .....</b>	<b>37</b>
Constructing the Foundation.....	37
Mounting When Casting the Pad.....	38
Mounting to an Existing Surface.....	38
Assembling the FD12P .....	40
Attaching the DTS14B Temperature Sensor to the Mast ...	41
Connecting Cables.....	43
Basic Wiring.....	43
Communication Cable EMC-shielding.....	46
Connecting a Background Luminance Sensor or a Day/Night Switch to FD12P .....	48
Communication Options .....	50
Serial Communications Settings.....	50
Serial Transmission RS-232 .....	50
Serial Multipoint Transmission RS-485 .....	51
Modem DMX21 .....	52
Indicators and Manual Controls.....	54
Indicators .....	54
Manual Controls .....	54
Analog Transmission .....	55
Connecting the Maintenance Terminal.....	55
Startup Testing.....	56
Initial Settings.....	56

CHAPTER 4

<b>OPERATION .....</b>	<b>59</b>
<b>Introduction .....</b>	<b>59</b>
<b>User Commands in Normal Operation.....</b>	<b>59</b>
<b>Markings Used in This Manual .....</b>	<b>61</b>
<b>Entering/Exiting the Command Mode.....</b>	<b>61</b>
OPEN Command .....	61
CLOSE Command .....	62
<b>Automatic Message Sending.....</b>	<b>62</b>
Message Types.....	63
Message 0 .....	64
Message 1 .....	64
Message 2 .....	65
Message 3 .....	65
Message 4 .....	66
Messages 5 and 6 .....	66
Message 7 .....	68
<b>Message Polling.....</b>	<b>69</b>
<b>FD12P Command Set.....</b>	<b>70</b>
HELP Command .....	70

---

MES Command .....	71
AMES Command.....	71
Weather Related Commands .....	73
WPAR Command.....	73
WSET Command .....	73
Precipitation Limit.....	74
Weather Update Delay.....	74
Haze Limit .....	74
Rain Intensity Scale.....	75
Violent Rain Limit .....	75
Heavy Rain Limit .....	75
Light Rain Limit.....	75
Drizzle Limit.....	75
Heavy Drizzle Limit.....	76
Light Drizzle Limit.....	76
Snow Limit.....	76
Heavy Snow Limit.....	76
Light Snow Limit.....	76
Snow Pellets Limit.....	77
Snow Grains Limit .....	77
Ice Crystals Limit.....	77
Hail Limit.....	77
DRD Scale.....	77
Warm Limit .....	77
PRW Command.....	77
CLRS Command .....	78
WHIS Command.....	78
System Configuration Commands.....	79
PAR Command.....	79
CONF Command.....	80
BAUD Command.....	84
BLSC Command.....	84
Maintenance Commands.....	85
STA Command .....	85
CAL Command .....	87
TCAL Command.....	87
CLEAN Command.....	88
CHEC Command.....	89
FREQ Command.....	89
DRY and WET Commands .....	89
AN Command .....	90
Analog Output Commands .....	91
Analog Output Calibration .....	91
Data Scaling .....	92
Hardware Check.....	92
Other Commands .....	93
TIME Command .....	93
DATE Command .....	93
RESET Command.....	94

CHAPTER 5

<b>FUNCTIONAL DESCRIPTION .....</b>	<b>95</b>
<b>General.....</b>	<b>95</b>
<b>Optical Measurement .....</b>	<b>96</b>

Optical Arrangement .....	96
FDT12B Transmitter Unit .....	96
FDR12 Receiver Unit .....	98
<b>Additional Measurements .....</b>	<b>99</b>
General .....	99
DRI21 Interface Board .....	99
DRD12 Rain Detector .....	100
DTS14B Temperature Sensor .....	101
<b>FDP12 Control Unit .....</b>	<b>101</b>
<b>Measurement Signal Processing.....</b>	<b>103</b>
Optical Signal Processing .....	103
DRD12 Signal Processing .....	104
<b>Algorithm Description .....</b>	<b>105</b>
Visibility .....	105
Detecting Precipitation .....	106
Precipitation Intensity .....	106
Precipitation Accumulation .....	107
Present Weather .....	108
Precipitation Types .....	108
Liquid Precipitation .....	109
Frozen Precipitation.....	110
Mixed Precipitation .....	111
Unknown Precipitation.....	111
Visibility Types .....	111
Fog.....	111
Haze and Mist.....	112
Weather Classes .....	112
Weather Code Selection.....	113
<b>Applications.....</b>	<b>113</b>
<b>Internal Monitoring .....</b>	<b>114</b>
Built-in Tests .....	114
Memory Tests .....	115
Signal Monitoring .....	115
Hardware Monitoring.....	115
Contamination Monitoring.....	116

CHAPTER 6

<b>MAINTENANCE .....</b>	<b>117</b>
<b>General .....</b>	<b>117</b>
<b>Cleaning .....</b>	<b>118</b>
Cleaning Lenses and Hoods.....	118
Cleaning DRD12 Rain Detector .....	118
<b>Calibration .....</b>	<b>119</b>
General .....	119
Visibility Calibration.....	119
Calibration Check Procedure.....	120
Calibration Procedure .....	123
Calibrating the DTS14B Temperature Sensor.....	124
Removing and Replacing.....	126
Removing and Replacing Optical Units .....	126
Removing and Replacing the DRD12 Rain Detector ..	129

Calibrating FD12P Weather Sensor after Unit Replacement .....	130
---	-----

CHAPTER 7

<b>TROUBLESHOOTING</b> .....	<b>133</b>
<b>Warnings</b> .....	<b>133</b>
<b>Troubleshooting Examples</b> .....	<b>133</b>
Message Indicating Warning or Alarm .....	133
Message Missing .....	134
Visibility Value is Missing.....	135
Visibility Value is Continuously Too Good.....	135
Visibility is Constantly Too Low .....	136
FDP12 Reports Precipitation When There Is None.....	136
FD12P Reports Frozen Precipitation during Rain .....	136
Have Jumper Settings Been Changed? .....	137
<b>Values for Internal Monitoring</b> .....	<b>137</b>
<b>Getting Help</b> .....	<b>140</b>
<b>Return Instructions</b> .....	<b>140</b>

APPENDIX A

<b>NWS AND WMO CODES USED IN FD12P</b> .....	<b>143</b>
<b>The NWS Codes</b> .....	<b>143</b>

APPENDIX B

<b>JUMPER SETTINGS AND INTERNAL WIRING</b> .....	<b>147</b>
<b>CPU Board</b> .....	<b>149</b>
<b>DC-Regulator</b> .....	<b>149</b>
<b>DRI21 Interface Board</b> .....	<b>149</b>

APPENDIX C

<b>TRANSMITTER AND RECEIVER TEST POINTS</b> .....	<b>151</b>
<b>INDEX</b> .....	<b>153</b>

## List of Figures

Figure 1	FD12P Weather Sensor Site .....	18
Figure 2	DRD12 Rain Detector and DTS14B Temperature Sensor .....	19
Figure 3	FD12P Block Diagram .....	21
Figure 4	Recommended Location for the FD12P .....	31
Figure 5	FD12P Equipment Grounding .....	33
Figure 6	Casting a Concrete Foundation.....	37
Figure 7	Constructing the FD12P Foundation .....	39
Figure 8	Tilting the Pole Mast .....	41
Figure 9	DTS14B and the Sensor Holder Assembly to Mast .....	42
Figure 10	Connecting Internal Grounding.....	43
Figure 11	Cabling Principle.....	44
Figure 12	Line Voltage and ON/OFF Switches.....	45
Figure 13	Electronics Enclosure Feedthroughs.....	46
Figure 14	Cable Grounding Instructions .....	47

Figure 15	Wiring the Connector for the LM11 Background Luminance Meter .....	49
Figure 16	Wiring the Day/Night Photo Switch .....	50
Figure 17	Communication Option .....	51
Figure 18	RS-485 Communication Option .....	52
Figure 19	Wiring the Modem .....	53
Figure 20	Analog Current Loop Option .....	55
Figure 21	FD12P Optical System .....	96
Figure 22	FDT12B Transmitter Block Diagram .....	97
Figure 23	FDR12 Receiver Block Diagram .....	98
Figure 24	DR121 Block Diagram in the FD12P Application .....	100
Figure 25	DRD12 Block Diagram .....	101
Figure 26	FDP12 Control Unit Block Diagram .....	102
Figure 27	Optical Raw Data (in Rain) .....	103
Figure 28	Optical Signal Amplitude Distribution (in Rain) .....	104
Figure 29	DRD12 Surface Signal (Heavy Rain Beginning) .....	104
Figure 30	Precipitation Type Determination Principle .....	109
Figure 31	Assembling the FDA13 Calibrator .....	122
Figure 32	DTS14 Sensor Holder Assembly to Mast .....	125
Figure 33	Removing the Optical Units .....	127
Figure 34	Replacing the Optical Units .....	128
Figure 35	Removing the DRD12 Rain Detector .....	129
Figure 36	Basic Electronics Enclosure Wiring .....	148
Figure 37	Test Points, Transmitter .....	151
Figure 38	Test Points, Receiver .....	152

## List of Tables

Table 1	Manual Revisions .....	12
Table 2	Related Manuals .....	12
Table 3	Basic Set .....	23
Table 4	Options .....	23
Table 5	Mains Cable Selection .....	35
Table 6	Communication Cable Lengths .....	35
Table 7	Transmit Frequencies of the DMX21 Modem Board .....	53
Table 8	LED Indicators of the DMX21 Modem .....	54
Table 9	Manual Controls of the DMX21 Modem .....	54
Table 10	Default Communication Settings .....	57
Table 11	Commands for Changing the Default Settings .....	57
Table 12	Commands for Displaying and Changing the Parameters .....	57
Table 13	Settings and Corresponding Commands .....	60
Table 14	Routine Command for Maintenance .....	60
Table 15	Status Report Command .....	60
Table 16	Transmitter Status Correspondence between MITRAS and FD12P .....	67
Table 17	Receiver Status Correspondence between MITRAS and FD12P67 .....	70
Table 18	HELP Command Sets .....	70
Table 19	Commands for Displaying or Setting Weather Analysis Parameters .....	73

---

Table 20	Commands for Displaying System Parameters and Editing the Current System Configuration .....	79
Table 21	Maintenance Commands.....	85
Table 22	Hardware Error Texts .....	86
Table 23	Hardware Warning Texts.....	86
Table 24	Parameters for Optical Measurement.....	131
Table 25	Parameters for DRD12 Precipitation Detector .....	131
Table 26	Parameters for DTS14 Temperature Sensor.....	131
Table 27	Updating Parameters.....	131
Table 28	Parameters and Commands.....	132
Table 29	Values for Internal Monitoring.....	138
Table 30	Internal Weather Types, NWS Code .....	143
Table 31	WMO SYNOP Codes (4680, W <sub>a</sub> W <sub>a</sub> ) .....	143
Table 32	WMO SYNOP Codes (4680, W <sub>a</sub> W <sub>a</sub> ) .....	144
Table 33	WMO SYNOP Codes (4680, W <sub>a</sub> W <sub>a</sub> ) .....	144
Table 34	WMO Code Table 4678. Codes Used by FD12P .....	145
Table 35	CPU Board Jumpers.....	149
Table 36	CPU Board Connectors .....	149
Table 37	DC-regulator Connectors.....	149
Table 38	DRI21 Interface Board Jumpers .....	149
Table 39	DRI21 Interface Board Connectors .....	150
Table 40	Electronics Enclosure/Transducer Cable Signals .....	150
Table 41	Transmitter Test Points.....	151
Table 42	Receiver Test Points.....	152

This page intentionally left blank.

# CHAPTER 1

## GENERAL INFORMATION

### About This Manual

This manual is a general information source as well as a detailed operational guide to the FD12P Weather Sensor.

### Contents of This Manual

This manual consists of the following chapters:

- Chapter 1, General Information, provides important safety, revision history, contact, and warranty information for the product.
- Chapter 2, Product Overview, introduces the FD12P Weather Sensor features, advantages, and the product nomenclature.
- Chapter 3, Installation, provides you with information to help you install this product.
- Chapter 4, Operation, contains information needed to operate this product.
- Chapter 5, Functional Description, gives a functional description on the product.
- Chapter 6, Maintenance, describes the overall maintenance of the product.
- Chapter 7, Troubleshooting, deals with troubleshooting information.
- Appendix A, NWS and WMO Codes Used in FD12P
- Appendix B, Jumper Settings and Internal Wiring
- Appendix C, Transmitter and Receiver Test Points

## Version Information

**Table 1      Manual Revisions**

Manual Code	Description
FD12P-U106en-1.2	Weather Sensor, User's Guide
M210296en-A	This manual.

## Related Manuals

**Table 2      Related Manuals**

Manual Code	Manual Name
DMX21T0496-1.1	DMX21 CCITT Modem
LM11T0545-1.2	LM11 Background Luminance Meter

## Safety

### General Safety Considerations

Throughout the manual, important safety considerations are highlighted as follows:

**WARNING**

Warning alerts you to a serious hazard. If you do not read and follow instructions very carefully at this point, there is a risk of injury or even death.

**CAUTION**

Caution warns you of a potential hazard. If you do not read and follow instructions carefully at this point, the product could be damaged or important data could be lost.

**NOTE**

Note highlights important information on using the product.

## Product Related Safety Precautions

The FD12P Weather Sensor delivered to you has been tested for safety and approved as shipped from the factory. Note the following precautions:

**WARNING**

Ground the product, and verify outdoor installation grounding periodically to minimize shock hazard.

**CAUTION**

Do not modify the unit. Improper modification can damage the product or lead to malfunction.

### Safety Summary

The following are general safety precautions must be observed during all phases of installation, operation and maintenance.

**WARNING**

Neglecting to follow these precautions or specific warnings and cautions elsewhere in this manual violates safety standards of design, manufacture and intended use of the instrument. Vaisala Oyj. and its Subsidiaries do not answer for the consequences if the customer neglects to follow these requirements.

### Ground the Equipment

To minimize the hazard of electrical shock, follow accurately the installation procedure in Chapter 3, Installation, on page 29.

**NOTE**

Note that the chassis of the FD12P Weather Sensor must be connected to a good electrical earth. The instrument is equipped with a three-conductor AC power cable. Be sure that the earth wire of the cable is connected to an electrical ground.

There is also a grounding clamp at the bottom of the electronics enclosure of Weather Sensor FD12P. Good grounding with a 16-mm<sup>2</sup>

cable must be provided. Besides increasing safety, this also protects the Weather Sensor against lightning induced voltages.

To prevent operator injury or damage to the Weather Sensor, check that the LINE VOLTAGE SETTING is correct before connecting the line power (See Figure 12 on page 45.) Also ensure that the line power outlet is provided with a protective ground contact.

**WARNING** Do not operate in an explosive atmosphere.

Do not operate the equipment in the presence of flammable gases or fumes. Operation of any electrical instrument in such an environment constitutes a definite safety hazard.

**WARNING** Do not service or adjust alone.

Do not attempt internal service or adjustment unless another person, capable of rendering first aid and resuscitation, is present.

**WARNING** Keep away from live circuits.

Component replacement or internal adjustments must be made by qualified maintenance personnel. Operating personnel must not remove instrument covers. Do not remove or replace any components with the power cable connected. Under certain conditions, dangerous voltages may exist even with the power cable disconnected. To avoid injuries disconnect power, and discharge all circuits before touching them.

**WARNING** Do not substitute parts or modify the instrument.

Because of the danger of introducing additional hazards, do not modify or substitute parts in the instrument. Contact Vaisala or its authorized representative for repairs to ensure that safety features are maintained.

**CAUTION**

The component boards including CMOS microchips should be transported and stored in conductive packages. Although new CMOS devices are protected against overvoltage damages caused by static electric discharge of the operator, careful handling is recommended: the operator should be properly grounded. Unnecessary handling of component boards should be avoided.

## Radio Frequency Interference Statement (USA)

The United States Federal Communications Commission (in 47 CFR 15.838) has specified that the following notice must be brought to the attention of users of this kind of a product in the USA:

*Federal communications commission radio frequency interference statement*

*This equipment generates and uses radio frequency energy and if not installed and used properly, that is in strict accordance with the manufacturer's instructions, may cause interference to radio and television reception. The Weather Sensor is designed to provide reasonable protection against such interference in an airport installation. However, there is no guarantee that interference will not occur in a particular installation. If this equipment causes interference to radio or television reception, which can be determined by turning the equipment off and on, the user is encouraged to try to correct the interference by one or more of the following measures:*

- *reorient the receiving antenna*
- *relocate this device with respect to the receiver*
- *move this device away from the receiver*

If necessary, the user should consult the dealer or an experienced radio/television technician for additional suggestions.

## ESD Protection

Electrostatic Discharge (ESD) can cause immediate or latent damage to electronic circuits. Vaisala products are adequately protected against ESD for their intended use. However, it is possible to damage the product by delivering electrostatic discharges when touching, removing, or inserting any objects inside the equipment housing.

To make sure you are not delivering high static voltages yourself, take the following precautions:

- Handle ESD sensitive components on a properly grounded and protected ESD workbench. When this is not possible, ground yourself to the equipment chassis before touching the boards. Ground yourself with a wrist strap and a resistive connection cord. When neither of the above is possible, touch a conductive part of the equipment chassis with your other hand before touching the boards.
- Always hold the boards by the edges and avoid touching the component contacts.

## Trademarks

Intel® is a registered trademark of the Intel Corporation in the U.S. and other countries.

## Warranty

For certain products Vaisala normally gives a limited one-year warranty. Please observe that any such warranty may not be valid in case of damage due to normal wear and tear, exceptional operating conditions, negligent handling or installation, or unauthorized modifications. Please see the applicable supply contract or conditions of sale for details of the warranty for each product.

## CHAPTER 2

# PRODUCT OVERVIEW

This chapter introduces the FD12P Weather Sensor features, advantages, and the product nomenclature.

## Introduction

The FD12P Weather Sensor is an intelligent, multi-variable sensor for automatic weather stations and airport weather observing systems. The sensor combines the functions of a forward scatter visibility meter and a present weather sensor. In addition, the sensor can measure the intensity and amount of both liquid and solid precipitation.

The FD12P can be used to automatically determine the visibility and precipitation related weather codes in the World Meteorological Organization (WMO) standard SYNOP and METAR messages. The sensor can also be employed as an observer's aid in a semi-automatic weather observing system. The sensor is also suitable for other weather observing systems providing valuable information, for example, to road and harbor authorities.

The versatility of the FD12P is achieved with a unique operating principle. The FD12P measures precipitation water content with a capacitive device and combines this information with optical scatter and temperature measurements. These three independent measurements together provide data sufficient for an accurate evaluation of current visibility and weather type.

## Hardware Structure

The structural basis of the FD12P is the pole mast that supports the transducer crossarm (FDC115). The crossarm contains the optical

units, FDT12B Transmitter and FDR12 Receiver. The DRD12 Rain Detector is fastened to the crossarm. The electronics enclosure with the main data processing and interface units is mounted to the pole mast as seen in Figure 1 below.

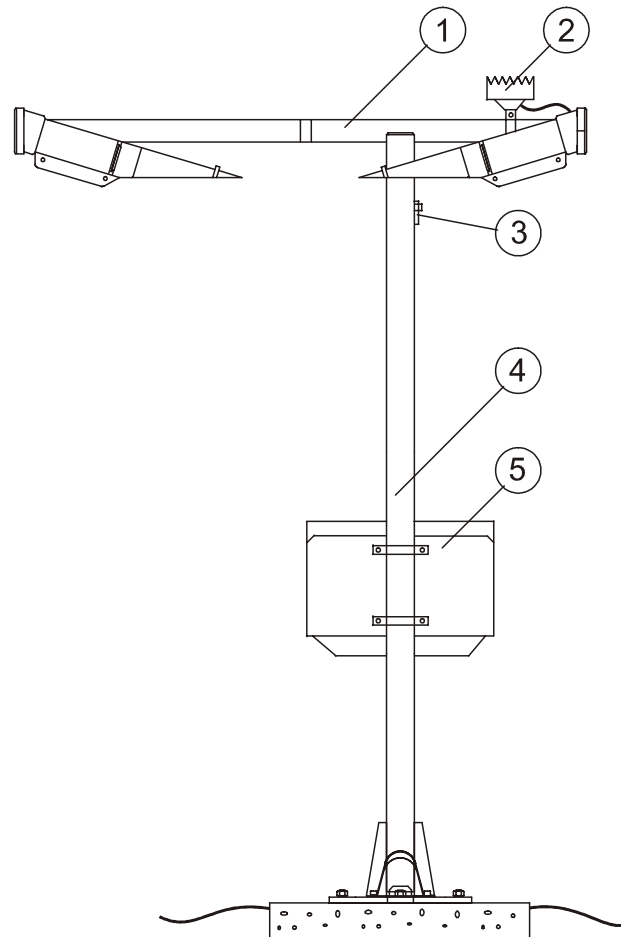

0201-085

**Figure 1**      **FD12P Weather Sensor Site**

The following numbers are related to Figure 1 above:

- 1 = Transducer crossarm
- 2 = DRD12 Rain Detector
- 3 = DTS14 Temperature Sensor
- 4 = Pole mast
- 5 = Electronics enclosure

The FD12P Weather Sensor consists of three parts: sensing elements, electronics enclosure, and structural elements. They are described in detail on the next page.

## Sensing Elements

The FDT12B Transmitter emits pulses of near infrared light. It is permanently tilted 16.5° downwards. The optical power is stabilized by a closed hardware loop. The unit also includes a receiver circuit for monitoring lens contamination.

The FDR12 Receiver measures the scattered part of the FDT12B light beam. The FDR12 contains also an additional light transmitter for monitoring lens contamination. Like the transmitter, the receiver is also tilted 16.5° downwards. Therefore, the receiver unit measures light scattered at an angle of 33°.

The DRD12 Rain Detector outputs a signal proportional to the amount of water on two RainCap™ sensing elements. These elements consist of thin wires protected by an insulating glass coating. The presence of water changes the capacitance of the elements. The combined capacitance of the plates is measured by the DRD12 electronics. Integrated heating resistors keep the elements dry when, for example, fog and melt snow fall on them. The Rain Detector is protected by a windshield to decrease the effect of wind on the measurement results. The DRD12 is illustrated in Figure 2 below.

The DTS14B Temperature Sensor is a Pt100 thermistor that is used to measure the crossarm temperature. See Figure 2 below.

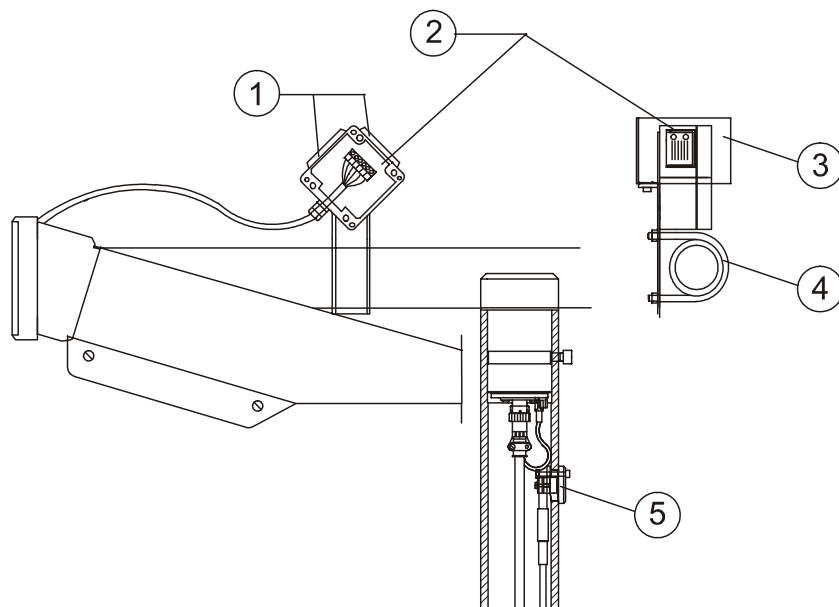

0201-086

**Figure 2** DRD12 Rain Detector and DTS14B Temperature Sensor

The following numbers refer to Figure 2 on page 19:

- 1 = Two RainCap™ elements
- 2 = DRD12 Rain Detector
- 3 = Wind shield
- 4 = Assembly clamp
- 5 = DTS14 Temperature sensor

## **Electronics Enclosure**

The FDP12 Control Unit is the main data processor and communication unit of the FD12P.

The DRI21 Interface Board is a Vaisala, general-purpose sensor interface, with several analog and digital input channels. In the FD12P, one of the DRI21 Interface Board channels is used for measuring the crossarm temperature and the DRD12 analog signal. In addition, the DRI21 controls the DRD12 heating and reads the precipitation ON/OFF status.

The FDW13 Mains Power Supply converts the mains voltage to 24 VAC power for the FDS12 regulator and the heater elements. The FDW13 includes also the mains voltage selector and the mains ON/OFF switch, which also functions as an automatic fuse.

The FDS12 DC Voltage Regulator converts the AC or DC input voltage (min. 18 V) to 12 VDC power used by FD12P electronics. The FDS12 also includes one relay used to control heater power.

The DMX21 Modem (optional) is a standard, 300-baud modem used only in the leased line mode with the FD12P.

The FDE12 Backup Temperature Sensor is included.

## **Structural Elements**

The structural elements include the pole mast with a standard height of 2 meters and the FDC115 Transducer Crossarm with a length of 1.5 meters, which is also the total width of the FD12P.

## Operating Principle

The FD12P Weather Sensor is a microprocessor controlled, intelligent sensor combining optical forward scatter measurement, capacitive precipitation sensing, and temperature measurement. The main units of the FD12P are shown in Figure 3 below.

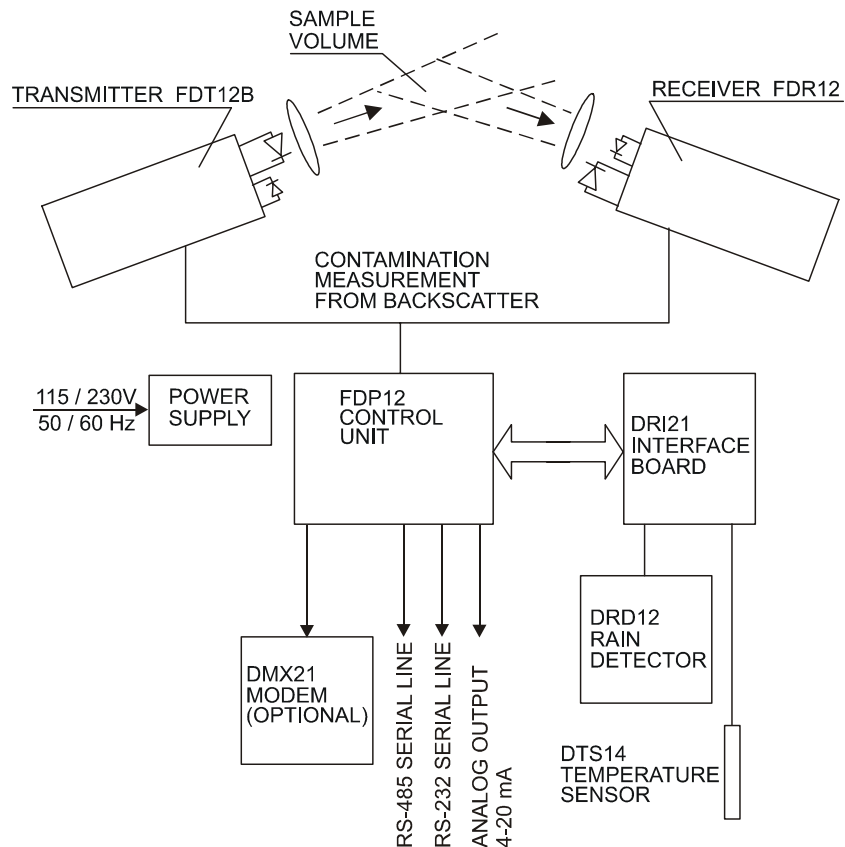

9502-091

**Figure 3** FD12P Block Diagram

The FD12P evaluates Meteorological Optical Range (MOR) by measuring the intensity of infrared light scattered at an angle of 33°. The scatter measurement is converted to the visibility value (MOR) after a careful analysis of the signal properties. Special processing is used in case of precipitation.

The FD12P software detects precipitation droplets from rapid changes in the scatter signal. The droplet data is used to estimate optical precipitation intensity and amount. In addition to the optical signal, the analog output of the DRD12 Rain Detector is used to estimate the precipitation intensity and type.

The output of the DRD12 is proportional to the water amount on the capacitive sensing surfaces while the optical intensity is proportional to the total volume of the reflecting particles. The ratio of optical and capacitive intensities is used to determine the basic precipitation type.

The crossarm temperature (TS) is measured with the DTS14B Temperature Sensor connected to the DRI21 interface card. The temperature data together with the optical signal profile and the DRD12 surface sensor data are used to determine the actual weather code.

The software performs all signal analyses in the FD12P except the DRD12 Rain ON/OFF status, which is hardware-based and is used as an auxiliary parameter. The FD12P has a fixed program that is divided into tasks executed under control of a real-time operating system kernel. Each task is like an endless loop with a limited function. The operating system kernel controls the timing of the tasks and the interactions between the tasks.

## Using FD12P

The FD12P is typically used as a component of a weather observing system. The final weather message (SYNOP, METAR) is then coded in the central unit of a weather observation system (for example, Vaisala MILOS 500) or by a human observer using the FD12P as an observation aid.

The FD12P output is a digital serial interface, which can be configured into two different operating modes: the sensor can be set to send a data message automatically at selected intervals, or the FD12P can be polled by the host computer. The same serial line is also used as an operator interface.

The operator controls and checks the operation of the FD12P by using a maintenance terminal. A set of built-in commands and test routines is provided for configuring and monitoring the multiple functions of the FD12P.

The standard data messages contain a status character for indicating faults detected by the internal diagnostics. If the error status is set, the operator can view a special status message. It contains detailed results of the diagnostics and a written description of the fault. Using this information, the operator can take corrective action or provide the maintenance personnel with valuable advice.

## Equipment Nomenclature

The standard equipment nomenclature and common names are listed in Table 3 and Table 4 below.

**Table 3 Basic Set**

Type	Name	Description
FDC115	Transducer Crossarm	Optics, analog, monitoring assembly
FDT12B	Transmitter	
FDR12	Receiver	
16614ZZ	Crossarm Cable	
FDB12	Electronics Enclosure	Power, conversions, interfacing assembly
FDP12	Processor Board	
FDS12	DC Voltage Regulator	
FDW13	Mains Power Supply	
DRI21	Interface Board	
16615ZZ	Transducer Cable	
16737ZZ	I/O Bus Cable	
DRD12	Rain Detector	
FD30513	Pole Mast	Standard 2-m mast
13145	Base Plate and Installation Set	

**Table 4 Options**

Type	Name	Description
FDA13	Visibility Calibration Set	
FD45094	Maintenance cable	RS232 cable with 9-pin D-connector.
Termbox-48	Mains and Signal Junction Box	Adapting/extending the local cable. Contains heavy-duty transient protection circuitry.
FD12MODEM	Modem Option	For remote communication.
FD12PLM11	LM11 Option	For ambient light measurement.
16616ZZ	Extended Transducer Cable	For optional high-mast mounting.

## Specifications

### Mechanical Specifications

- Dimensions: 2.3 m × 1.6 m × 0.6 m (H × W × D)
- Weight: 35 kg, excluding the installation plate for the pole mast
- Mounting: on a concrete foundation with three Ø16-mm bolts
- Material: anodized aluminum, natural gray

### Electrical Specifications

- Mains supply: 115/230 VAC ± 20 %, 45 ... 65 Hz
- Maximum power consumption: 35 W + 100 W defrosting heaters (in cold weather)

The sensor electronics:

- Lock-in amplifier
- LED power stabilizer
- Contamination monitor
- Lens heater

The control unit:

- Intel 8031 microprocessor
- Program memory, 64 Kbytes
- Read/write memory, 32 Kbytes

Outputs:

- Serial data line may be used either as RS-232 level signals or interfaced via an optional data modem
- RS-485 (2-wire)
- 4 - 20 mA analog current (sink) output

The output data:

- Automatic or polled data message
- Visibility, present weather, precipitation and status data
- Automatic message type and interval is selectable at 15 seconds to  $n \times 15$  seconds ( $n < 18$ ) intervals

The analog visibility output:

- Selectable range and mode (linear or logarithmic)
- Status control bit for remote alarm relay, etc.
- Alarms and warnings (hardware failures, visibility limits)

## Optical Specifications

Operating principle:

- Forward scatter at an angle of  $33^\circ$  and capacitive rain sensor.

The light transmitter:

- Light source: near-infrared LED
- Peak wavelength: 875 nm
- Modulation frequency: 2.3 kHz
- Transmitter lens diameter: 71 mm
- Reference photodiode: for light source control
- Backscatter photodiode: for contamination and blockage measurement

The light receiver:

- Photodiode: PIN 6 DI
- Spectral response: max. responsivity at 850 nm, 0.55 A/W  
(in range 550 ... 1050 nm over 0.3 A/W)
- Reception lens diameter: 71 mm
- Backscatter light source: near-infrared LED for contamination and blockage measurement

## Capabilities and Limitations

### Visibility Measurement Specifications

Measurement range of Meteorological Optical Range (MOR):

- 10 ... 50 000 m according to a 5 % Contrast Threshold Definition

Accuracy:

- $\pm 10\%$ , range 10 ... 10 000 m
- $\pm 20\%$ , range 10 000 ... 50 000 m

Instrument consistency:

- + 4 %

Update interval:

- 15 seconds

### Weather Sensing Specifications

Precipitation detection sensitivity:

- 0.05 mm/h or less, within 10 minutes

Weather type identification:

- 11 different types of precipitation
- Fog (mist) and haze (smoke, sand)

Weather type reporting:

- WMO code table 4680 (with some additions from code table 4677)
- Code letters for precipitation, NWS
- WMO code table 4678 (supported codes are shown in Table 34 on page 145).

Precipitation intensity measurement:

- Range 0.00 ... 999 mm/h
- Accuracy  $\pm 30$  % (range 0.5 ... 20 mm/h, liquid precipitation)

## Environmental Specifications

Operating temperature range:

- $-40 \dots +55$  °C

Operating humidity range:

- Up to 100 % RH

Wind speed:

- Up to 60 m/s (standard mast)

Sun orientation:

- Direct and reflected sunlight into the light receiver must be avoided.

This page intentionally left blank.

## CHAPTER 3

# INSTALLATION

This chapter provides you with information to help you install this product.

**NOTE**

Before installation, read section Product Related Safety Precautions on page 13.

## Organizing Installation

Before you begin to install the FD12P Weather Sensor, make a plan of the installation steps. The following is an example of how to organize the installation process.

1. Surveying the site:
  - Find the most representative measurement site.
  - Determine orientation of the Weather Sensor.
2. Cabling plan is required for the following:
  - Grounding cabling layout and cable type.
  - Power supply cabling layout and cable type.
  - Modem/signal cabling layout and cable type.
3. Ordering the construction materials and cables.
4. Digging for cables and foundation.
5. Casting the concrete:
  - Prepare concrete blocks by using a casting mold.
  - Cast the fixing bolts in their places at the same time.

6. Installing the base plate and the pole mast:
  - Install the base plate with the bolts on the concrete block.
  - Level the plate.
  - Mount the pole mast on the base plate.
  - Mount the junction box to the pole mast (optional). Junction boxes are available from Vaisala.
7. Connecting cables:
  - Connect the mains and signal cables of the site to the junction box or have them ready for direct connection to the sensor.
8. Final installation:
  - Install the electronics enclosure and the crossarm of the FD12P to the pole mast.
  - Connect the power and signal cables of the FD12P.
  - Connect the modem/signal line to the host computer, display, etc.
9. Start-up tests for the system.

## Location and Orientation

The main requirements for the location of the FD12P are as follows:

1. Place the FD12P at a site where the measurements will be representative of the surrounding weather conditions.

The ideal site has a minimum clearance of 100 meters from all large buildings and other constructions that generate heat and/or obstruct precipitation droplets. Also avoid shading of trees as this may cause changes in the microclimate.

2. Make sure the site is free of obstacles and reflective surfaces, which disturb the optical measurements and act as obvious sources of contamination.

There must not be any obstacles in the line-of-sight of the transmitter and receiver units (see Figure 4 on page 31). If the transmitter beam is reflected from obstacles back to the receiver unit, the sensor will indicate too low MOR values as the reflected signal cannot be distinguished from the real scatter signal. Reflections are detected by rotating the sensor crossarm. They will change depending on the crossarm orientation. Also the visibility reading will change accordingly.

The receiver and transmitter optics should not point towards powerful light sources or, in bright daylight, reflective surfaces such as snow or sand. The receiver should point north in the Northern Hemisphere and south in the Southern Hemisphere. The receiver circuit may become saturated in bright light, and the built-in diagnostics will indicate a warning. Intense light can generate false contamination alarms from the transmitter unit. Bright daylight will also increase the noise level in the receiver.

The transmitter and receiver should face away from any obvious source of contamination such as spray from passing vehicles. Dirty lenses will cause the sensor to report too high visibility values. Excessive contamination is automatically detected by the sensor.

Harmful reflections are typically avoided if the transmitter beam is directed towards a surface, which will reflect most of the light away from the sensor. The distance of 6 meters shown in Figure 4 below is only for guidance; it is not an absolute requirement.

There should be no flashing lights near the sensor. A flashing light can cause errors in detecting precipitation towards

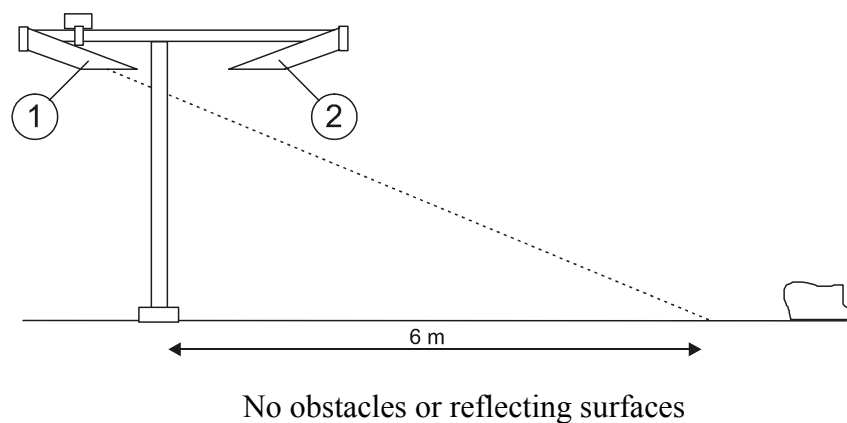

0110-178

**Figure 4 Recommended Location for the FD12P**

The following numbers refer to Figure 4 above.

- 1 = Transmitter
- 2 = Receiver

3. Power supply and communication lines must be available.

When the site for the FD12P is selected, take into consideration the available power supply and communication lines. This influences the amount of work and accessories needed and thus, the actual installation costs.

## Grounding and Lightning Protection

### Equipment Grounding

Equipment grounding protects the electrical modules of the FD12P, for example, against lightning and prevents radio frequency interference. The FD12P equipment is grounded using a jacketed grounding cable and conductive grounding rod(s).

The FD12P must be grounded by means of the grounding clamp, which is located under the cable flange (See Figure 5 on page 33). A 16-mm<sup>2</sup> jacketed grounding cable is connected to the clamp. Depending on the need, one to four copper-sheathed steel rods are driven into the ground. If several rods are needed, the alignment from the foot of the base plate must be radial.

The grounding principles are the following:

- The grounding rod must be installed as close to the pole mast as possible to minimize the length of the grounding cable. The grounding cable can be also cast inside the concrete base.
- The length of the grounding rod depends on the local groundwater level. The lower end of the grounding rod must continuously touch moist soil.

The grounding quality can be checked with a georesistance meter. The resistance must be less than 10 ohms. This way the lowest possible resistance is achieved.

The junction box must be also grounded via the grounding cables in the same way as the electronics enclosure (Figure 5 on page 33). The junction box is optional.

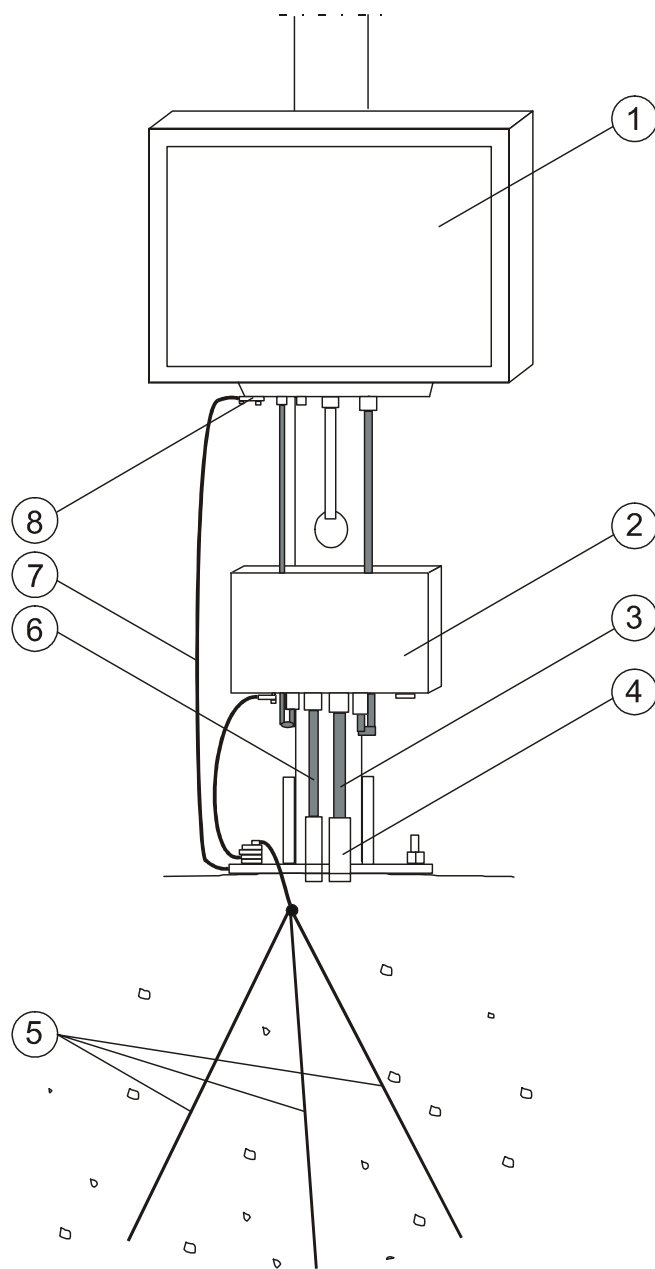

0111-001

**Figure 5** FD12P Equipment Grounding

The following numbers refer to Figure 5 above:

- 1 = Electronics enclosure
- 2 = Junction box (optional)
- 3 = Mains cable
- 4 = Cable tubing
- 5 = Grounding rods
- 6 = Signal cable
- 7 = 16 mm<sup>2</sup> grounding cables
- 8 = Grounding clamp

## Internal Grounding

The electronics enclosure and the bottom plate of the FD12P are secured by a 1.5-mm<sup>2</sup>, yellow-green ground cable and the crossarm is grounded through the transducer cable shield. The other parts of the crossarm are in galvanic contact with each other.

### **CAUTION**

When installing the FD12P, the grounding flat connector must be plugged to the ground terminal socket, which is located beside the MIL-connector in the crossarm. See instructions in section Assembling the FD12P on page 40 and Figure 10 on page 43.

## Grounding for Testing Purposes

The FD12P is provided with a two-meter mains cable. The cable has a grounded plug. The plug must be connected only to an outlet that has a ground terminal. This grounding is sufficient when the instrument is used indoors, for example, for testing purposes.

## Grounding Remote Units and Communication Cable

Remote units, such as, the PC data logger, must be grounded and protected against lightning.

### **WARNING**

A lightning strike through a communication wire can cause a voltage surge dangerous to life at remote sites if the remote units are not properly grounded.

## Cable Selection

### Line Power Cabling

The FD12P is supplied with a two-meter power cable. If a local terminal for 115/230 VAC power supply is not available, use an extended mains cable from the FD12P to the nearest power source. This cable should be armored and of underground type. The armored reinforcing acts as a mechanical shield and also provides protection against lightning. Ground the cable screen at both ends.

The recommended mains wire cross sections are shown in Table 5 below for mains voltage 230 VAC. For 115 VAC, divide the maximum distances by four.

**Table 5 Mains Cable Selection**

Maximum Distance from Voltage Source	One-wire Cross-section Area	Nearest AWG-gauge	Typical Non-armored Cable Diameter
2 km	1.5 mm <sup>2</sup>	No 15 AWG	10 mm
4 km	2.5 mm <sup>2</sup>	No 13 AWG	14 mm
8 km	4.0 mm <sup>2</sup>	No 11 AWG	18 mm

#### NOTE

Cables with diameters more than 12 mm require a separate junction box which is also available from Vaisala.

### Communication Cable

The FD12P provides the RS-232C, RS-485, CCITT V.21 modem, and analog transmission interfaces. Consider your needs for communication before the installation. The communication method depends on the distance between the computer or display and the FD12P and the number of the FD12P sensors. Table 6 below describes the possibilities.

**Table 6 Communication Cable Lengths**

Cable Length	One FD12P	Several FD12Ps on line
< 150 m	RS-232	RS-485, modem
< 500 m	RS-485, modem	RS-485, modem
> 500 m	Modem	Modem

For a modem and RS signal cable, use a screened,  $2 \times 0.22\text{-mm}^2$  twisted pair cable with a minimum diameter of 5 mm. For details, see section Communication Options on page 50.

## Unloading and Unpacking

The contents of the delivery in question are specified in the packing list included with the delivery documents. The FD12P equipment is normally delivered in three cases containing the following parts:

- Crossarm FDC115 containing the optics.
- Electronics enclosure FDB12 with radiation shield.
- Pole mast.

Two persons can easily move the cases from a truck to the installation site.

<b>NOTE</b>	Handle gently the case containing the optical parts. Do not drop either end of the case.
-------------	--

## Unpacking Procedure

1. Read the packing list supplied within the delivery documents. Compare the packing list against the purchase order to make sure that the shipment is complete.
2. Open the covers.
3. In case of any discrepancies or damage, contact the supplier.
4. Place the packing materials and covers back in the cases and store them for possible reshipment.

## Storage Information

Store the FD12P in its packages in dry conditions, not in the open air. The storage conditions are as follows:

- Temperature  $-40\text{ }^{\circ}\text{C} \dots 70\text{ }^{\circ}\text{C}$ .
- Relative humidity up to 95 %.

## Installation Procedures

### Constructing the Foundation

Cast a concrete foundation or use an existing construction that is level and rigid. The recommended minimum dimensions for the foundation are illustrated in Figure 6 below. It is easiest to mount the foundation screws while casting the pad. If the pad was casted earlier, drill three holes into the concrete for the wedge bolts.

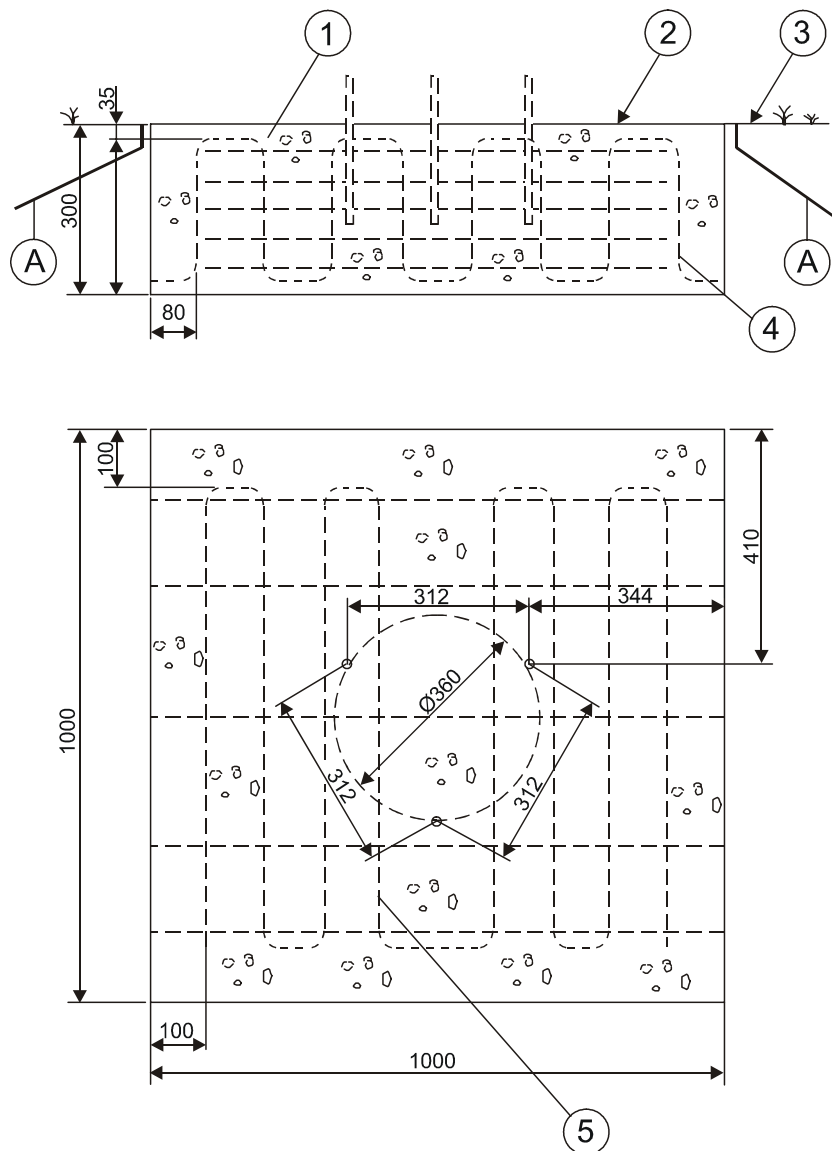

0110-179

**Figure 6 Casting a Concrete Foundation**

The following numbers and letters refer to Figure 6 on page 37:

- A = Watertight plastic for conducting rainwater away (recommended)
- 1 = Concrete block
- 2 = Surface horizontal to  $\pm 0.5^\circ$
- 3 = Ground level
- 4 = Reinforcing steel
- 5 = Reinforcing steel or use steel mesh  $150 \times 150$  mm

The Installation Set included in the FD12P delivery contains the required equipment both for mounting when casting the pad and mounting to an existing surface. Use the triangle shaped template as an auxiliary device and remove it before mounting the base plate.

### **Mounting When Casting the Pad**

1. Fasten the three reinforcing plates to the lower end of the foundation screws with six M16 nuts. See Figure 7 (C, top view) on page 39.
2. Fix the template to the upper ends of the foundation screws with six nuts.
3. Embed the assembly in the concrete foundation as shown in Figure 7 on page 39.
4. After the concrete has set, remove the template.

### **Mounting to an Existing Surface**

1. Drill three,  $\varnothing 20$ -mm holes using the template, minimum depth 65 mm. Refer to Figure 7 on page 39.
2. Remove the template.
3. Clean the holes.
4. Fasten the foundation screws to the wedge bolts by hand.
5. Protect the tops of the screws with two nuts tightened together.
6. Then place the wedge bolt and foundation screw combinations in the holes, wedge bolts down, and hammer the combinations down.
7. Tighten the foundation screws as tight as possible.

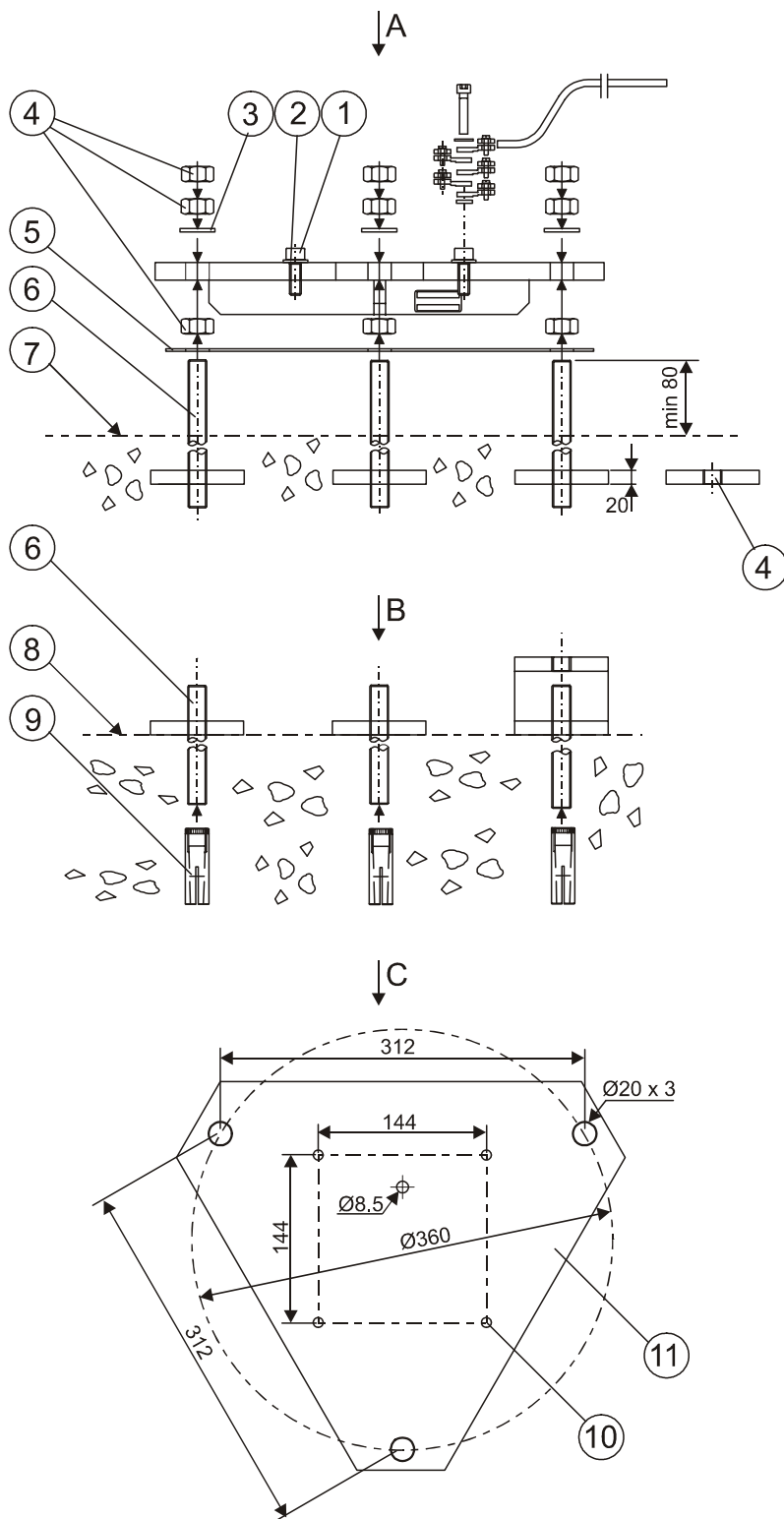

0110-180

**Figure 7** Constructing the FD12P Foundation

The following numbers and letters refer to Figure 7 on page 39:

- A = Mounting when casting the pad
- 1 = A10.5 DIN125, 4 pieces
- 2 = M10 x 30 DIN933, 4 pieces
- 3 = A17 DIN125, 3 pieces
- 4 = M16 DIN934, 3 pieces
- 5 = Template
- 6 = Foundation screw M16 x 250, 3 pieces
- 7 = Base level
- B = Mounting to an existing surface
- 6 = Foundation screw M16 x 250, 3 pieces
- 8 = Template
- 9 = Wedge bolt M16, 3 pieces
- C = Top view
- 10 = M10, 4 pieces
- 11 = Baseplate

## Assembling the FD12P

1. Mount the base plate and level it with the six M16 nuts.
2. Mount the pole mast pedestal and the tilting support on the base plate with four M10 bolts (Figure 7 on page 39, C, top view).
3. Attach the electronics enclosure to the pole mast with two clamps and four M6 Allen screws.
4. Tilt the mast. See Figure 8 on page 41.
5. Feed the crossarm cable and temperature sensor DTS14B cables inside the pole mast.
6. Check that a thin rubber gasket is on the insertion neck of the crossarm.
7. Connect the crossarm cable plug to the MIL-connector (see Figure 10 on page 43).
8. Connect the grounding flat connector to the other pin of the ground terminal socket as shown in Figure 10 on page 43.

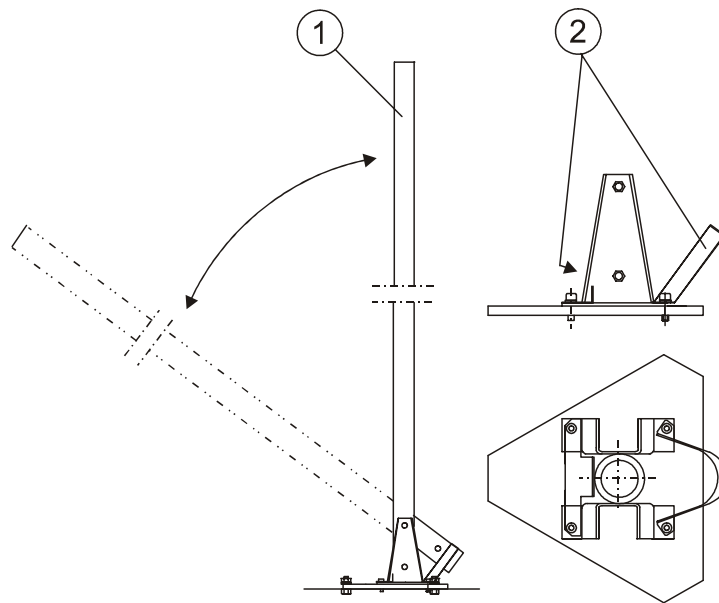

0110-181

**Figure 8 Tilting the Pole Mast**

The following numbers refer to Figure 8 above:

- 1 = Pole mast. For tilting, loosen the upper and remove the lower M10 × 100 bolts.
- 2 = Tilting supporters. To be installed under the fastening screws.

## Attaching the DTS14B Temperature Sensor to the Mast

To attach the DTS14B Temperature Sensor to the mast, do the following:

1. Pull the DTS14B temperature sensor out of the side hole of the mast.
2. Then attach the holder to the mast in the following way:
  - Open the fixing screw fully (part 3 below).
  - Push the screw head to the holder with you finger.
  - Put the holder to the hole in the mast pole.
  - Slide the holder upwards as long as it goes and hold it there.
  - Tighten the fixing screw firmly.

- Insert the crossarm to the pole mast and lock it in the right position with two 8-mm bolts.
- Erect the mast.
- Lift the DRD12 Rain Detector to an upright position. Tighten the clamp.

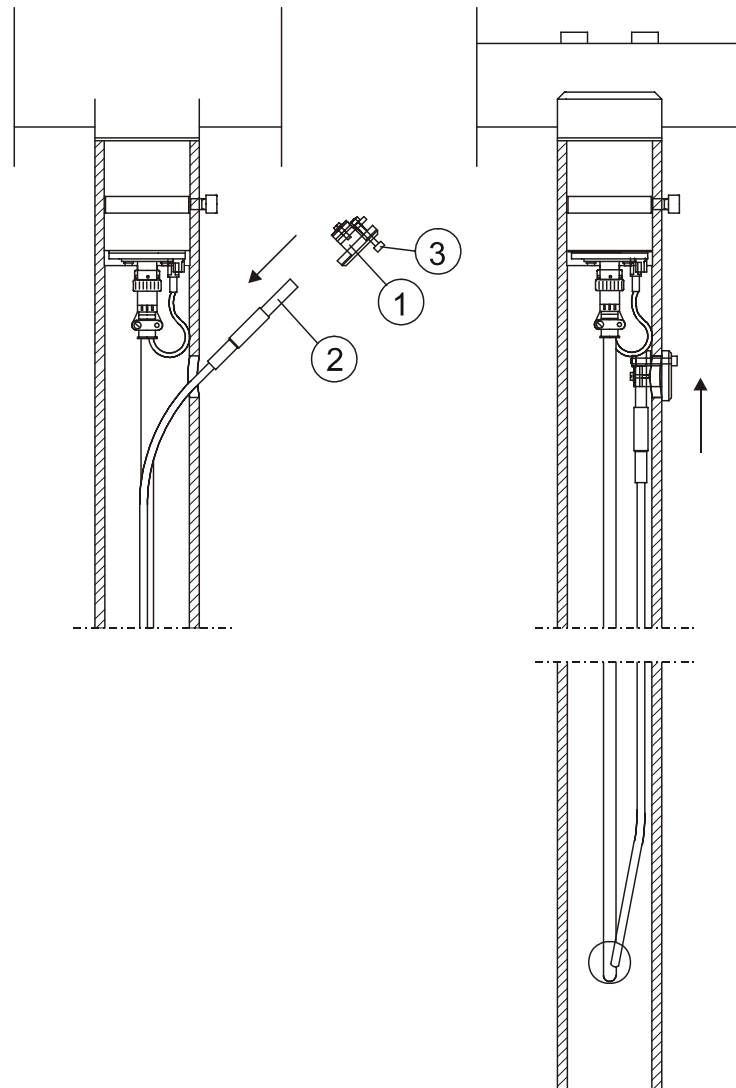

0201-088

**Figure 9 DTS14B and the Sensor Holder Assembly to Mast**

The following numbers refer to Figure 9 above:

- 1 = Sensor holder
- 2 = DTS14
- 3 = Fixing screw

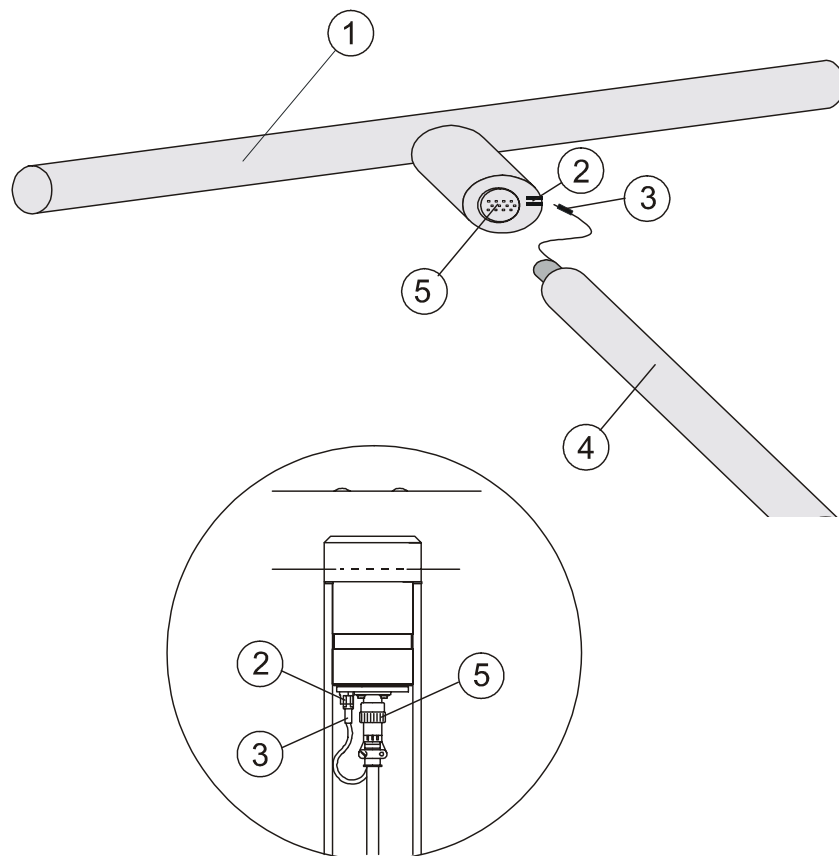

0110-182

**Figure 10 Connecting Internal Grounding**

The following numbers refer to Figure 10 above:

- 1 = Crossarm
- 2 = Ground terminal socket
- 3 = Grounding flat connector
- 4 = Pole mast
- 5 = MIL-connector

## Connecting Cables

### Basic Wiring

To do the basic wiring, do the following:

1. The electronics enclosure includes a power cable. Remove the plug.

If you use another, longer cable, make sure to connect the wires in a correct way, especially the protective ground wire (usually yellow-green). Refer to Figure 11 below.

2. Connect the power cord to the screw terminals in a junction box or bring the power line directly to the electronics enclosure. The selected method depends on the thickness of the power cable, which should be checked before the installation. The electronics enclosure has a cable outlet with a diameter of 10 - 12 mm.
3. Feed Neutral N (normally blue) and protective earth PE (normally yellow-green) via separate conductors.
4. Feed the communication cable through one of the two cable feedthroughs. For cable shield connections, see instructions in section Communication Cable EMC-shielding on page 46.
5. Wire the communication cable according to instructions in section Communication Options on page 50.

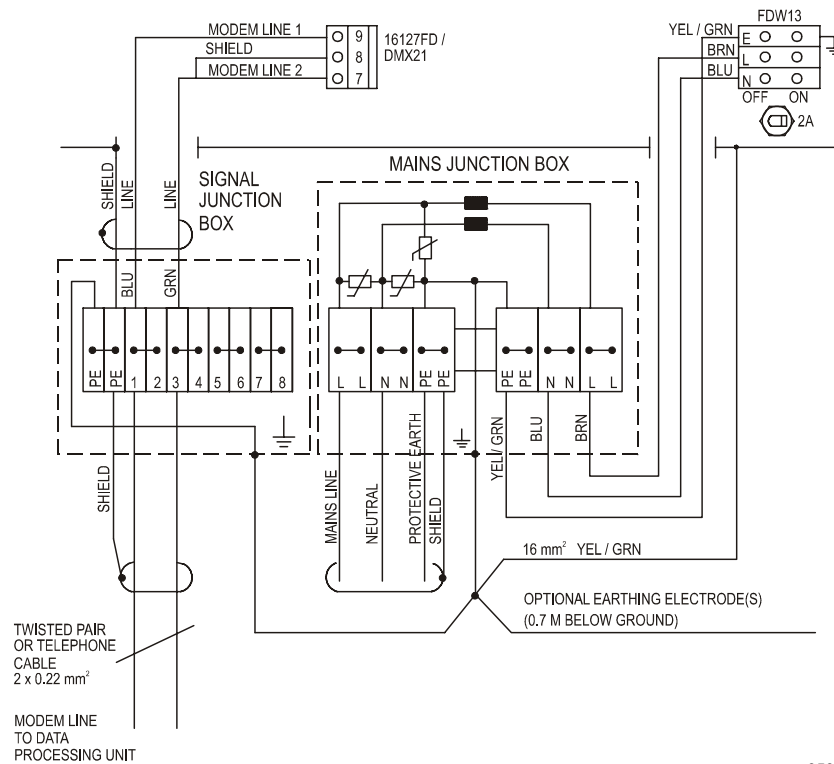

9509-011

**Figure 11 Cabling Principle**

**NOTE**

If the line voltage used differs from 230 V (the initial setting at the factory), check the voltage setting of the FDW13 Mains Power Supply (alternatives 115 VAC and 230 VAC). You can find the line voltage setting switch on the left side of the FDW13 unit (see Figure 12 below).

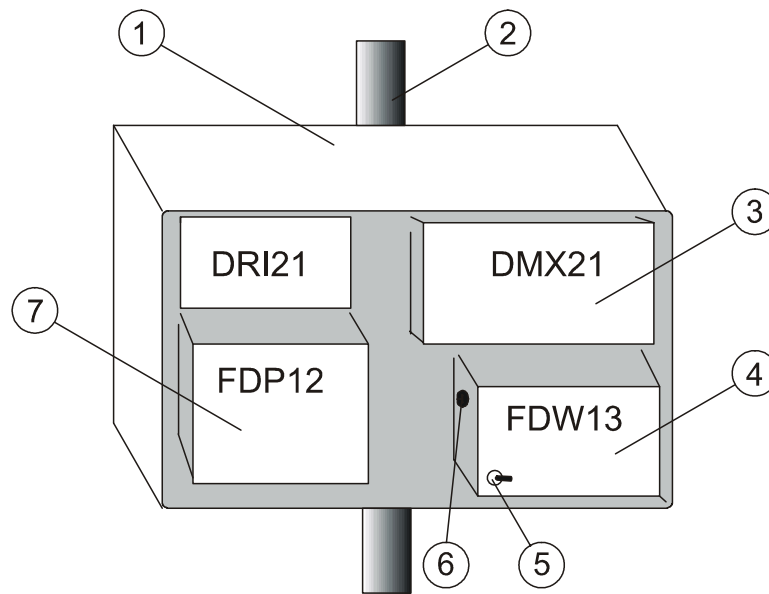

0110-183

**Figure 12 Line Voltage and ON/OFF Switches**

The following numbers are related to Figure 12 above:

- 1 = Electronics enclosure
- 2 = Pole mast
- 3 = DMX21 modem
- 4 = DC regulator FDW13
- 5 = ON/OFF switch
- 6 = Line voltage setting
- 7 = FD12P control unit

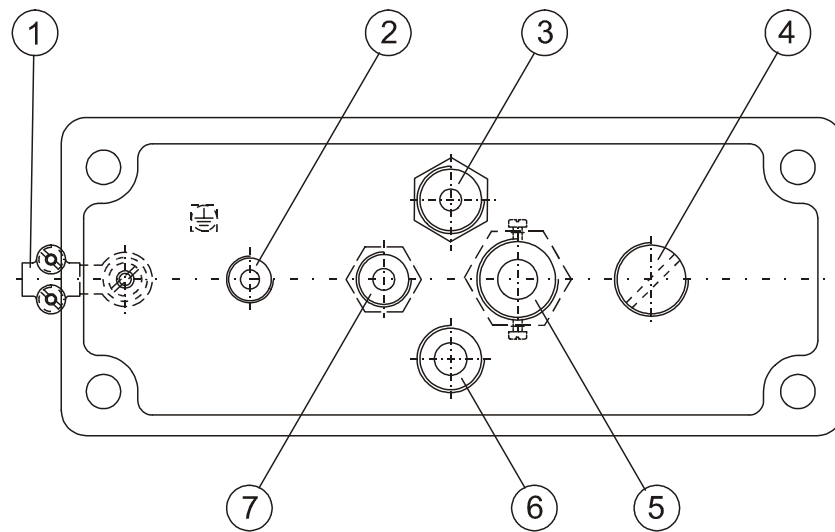

0110-184

**Figure 13 Electronics Enclosure Feedthroughs**

The following numbers refer to Figure 13 above:

- 1 = Grounding
- 2 = DTS14 cable feedthrough
- 3 = Temperature sensor (TE)
- 4 = Cap (Pg 13.5) of optional opening for the LM11 background luminance meter
- 5 = Main power cable
- 6 = FDC115 transducer cable feedthrough
- 7 = Standard communication cable feedthrough

## Communication Cable EMC-shielding

The electronics enclosure has one cable outlet for a cable diameter from  $\text{Ø}7$  to  $\text{Ø}10$  mm, which is reserved for a signal or modem cable. Although the shielding of the cable may be just grounded after cable inlet, an efficient procedure against RF-interference requires special care. Ground the cable gland to keep EMI levels within specifications.

For a proper RF-grounding of any jacketed cable, the instructions are the following:

1. Lead the signal cable through the cable inlet. If the field cable is thicker than 10 mm, use a separate signal junction box. See Figure 14 on page 47.
2. Strip 80 mm of the cable sheath leaving approximately 40 mm of the shield.

3. Remove the cap of the cable gland, including the rubber cylinder and the metal rings. Slide the cap with rubber cylinder onto the cable.
4. For a thin cable, add a shrinkable tube to increase cable diameter.
5. Slide two metal rings on the shielding and squeeze it evenly between the rings.
6. Secure with a shrinkable tube.
7. Tighten the cable with the cable gland and proceed with the wiring.
8. Connect the signal cable to the screw terminals in the electronics enclosure.
9. Ground the signal cable with the same method at both ends.

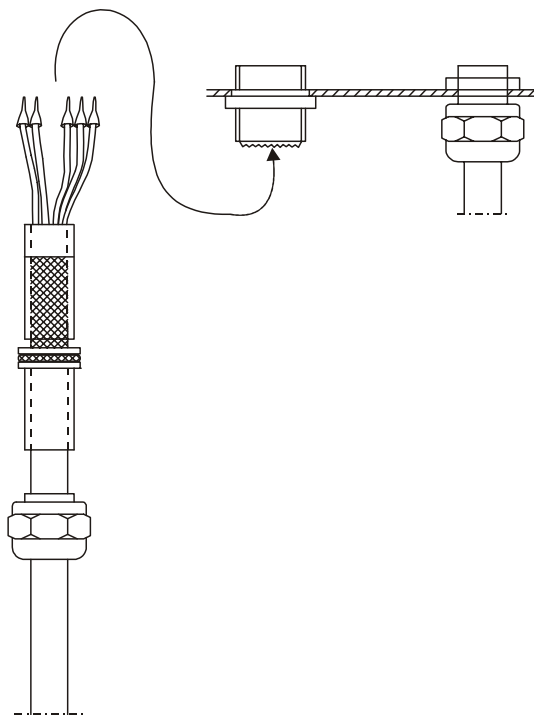

0205-006

**Figure 14 Cable Grounding Instructions**

## **Connecting a Background Luminance Sensor or a Day/Night Switch to FD12P**

The FD12P Weather Sensor supports two different methods for ambient light sensing. The Background Luminance Meter LM11 can be connected to the FD12P for accurate ambient light measurement. The LM11 sensor and necessary wiring are included in option FD12PLM11 (see Figure 15 on page 49 for the wiring details). The background luminance measurement is typically used in the RVR systems.

The LM11 output frequency is measured with the DRI21 interface board and then converted into background luminance by the FD12P software. The conversion uses a scaling factor, which needs to be configured by the user. For details, see section BLSC Command on page 84.

In certain applications it is necessary to calculate night visibility separately using a formula that differs from MOR. In these cases a simple day/night photo switch is sufficient for discerning between day and night ambient light conditions. The switch can be connected to the serial line control input on the FDP12 processor board. For wiring details, see Figure 16 on page 50.

Positive voltage is interpreted as a night condition and the background luminance value in the FD12P output message is set to 0. Negative voltage or an open circuit is interpreted as a day condition and the luminance value is set to 1. For details, see section BLSC Command on page 84.

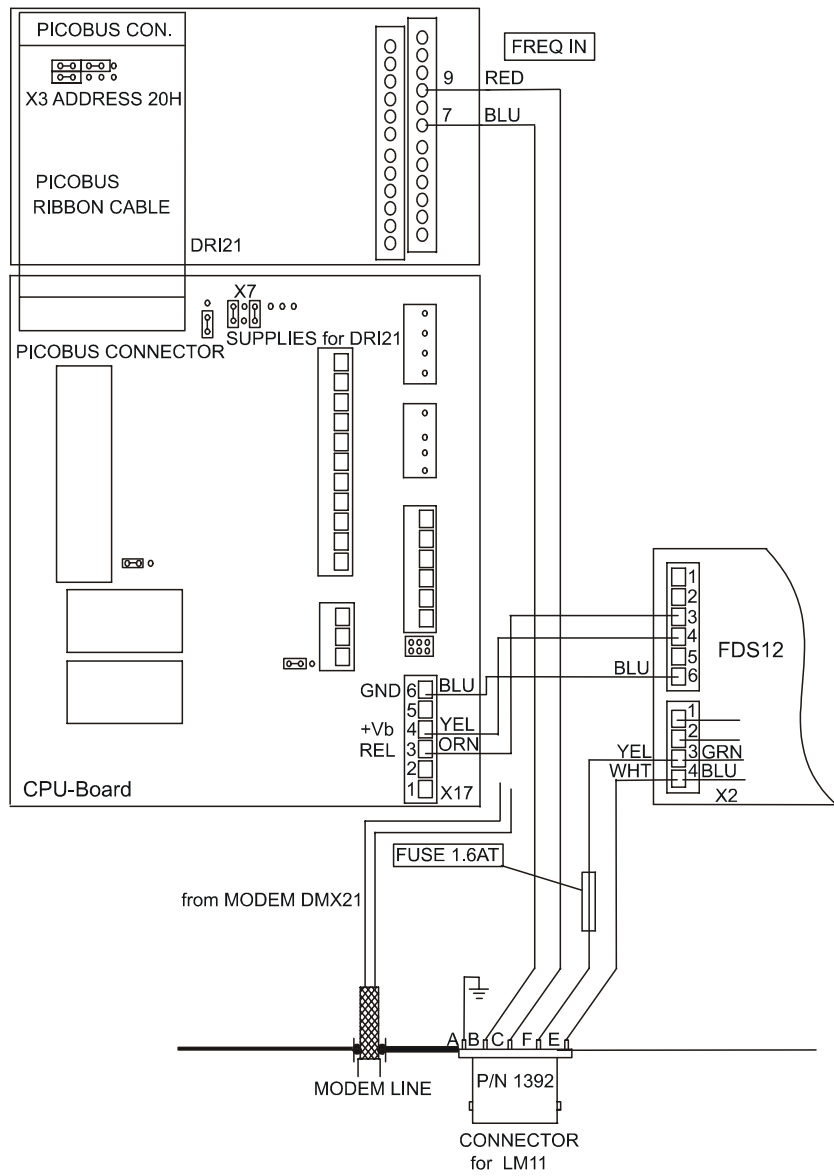

9610-006

**Figure 15** Wiring the Connector for the LM11 Background Luminance Meter

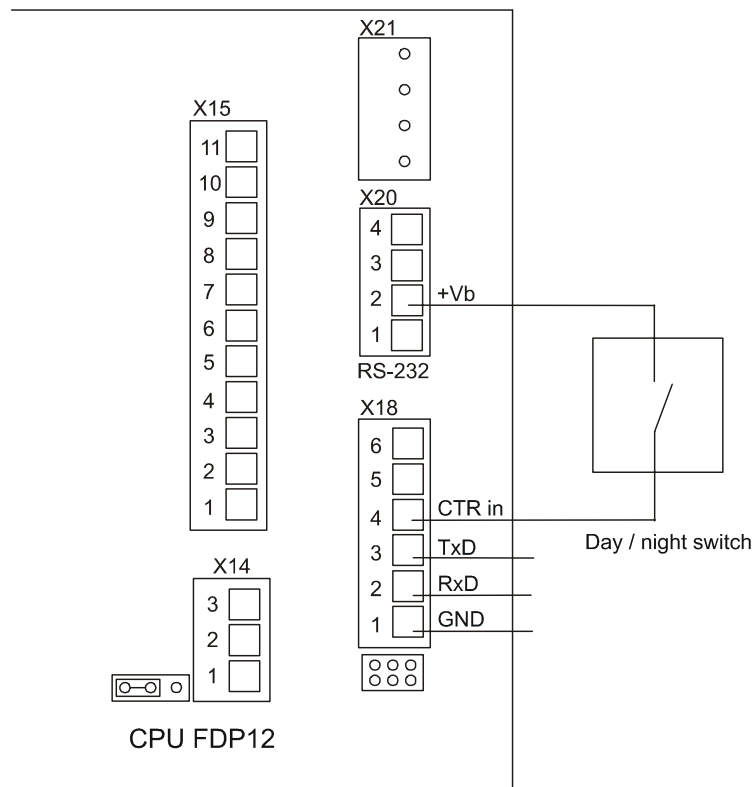

9610-007

**Figure 16** Wiring the Day/Night Photo Switch

## Communication Options

### Serial Communications Settings

**NOTE**

The factory default settings of the FD12P serial communications port are 300 baud. Even parity is 7 data bits, 1 stop bit.

### Serial Transmission RS-232

For the RS-232 communication, connect the signal wires to screw terminal X18 (CTR lines not needed) at CPU board FDP12. See Figure 17 on page 51.

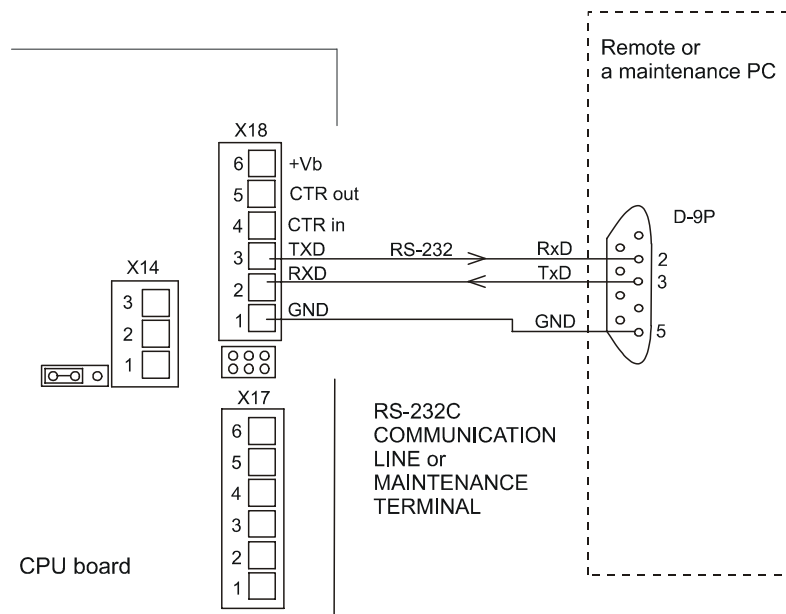

9509-013

**Figure 17 Communication Option**

The Vaisala recommendation for the maximum length of the RS-232 cable is 150 m (500 ft).

### Serial Multipoint Transmission RS-485

The RS-485 transmission standard allows several FD12Ps to communicate (half duplex) with the host computer using a single twisted pair. For the RS-485 communication, connect the signal wires to 4-pin screw connector X21 at the CPU board. See Figure 18 on page 52.

In the multidrop configuration, where several FD12P Weather Sensors are on the same communication line, units are differentiated by an ID. Set a different unit ID to each FD12P with the CONF command. Set FD12 P to the polling mode with the AMES 0 2 command. The host system must ask data messages by polling each FD12P.

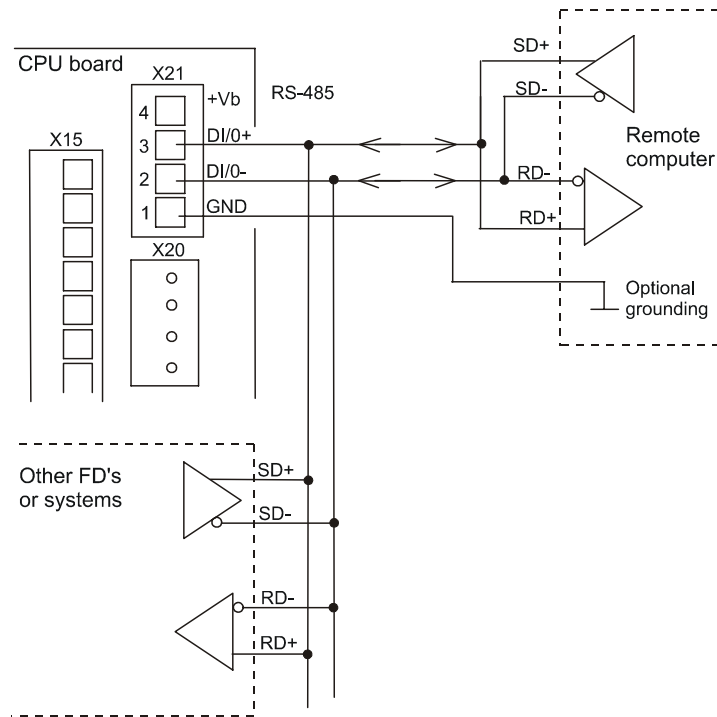

9509-014

**Figure 18 RS-485 Communication Option**

### Modem DMX21

The Modem DMX21 is a CCITT V.21 modem, operating at 300 bps. Connect the signal wires to MODEM LINE 1 and 2, and screw terminals 7 and 9 on Interface board 16127FD. See the wiring diagram in Figure 19 on page 53.

In the multidrop configuration, where several FD12P Weather Sensors are on the same modem line, the units are differentiated by an ID. Set a different unit ID to each FD12P with the CONF command. In the multidrop configuration, only one FD12P modem carrier can be active at the time. To set the modem carrier under the FD12P software control, set jumper X2 to position 1-3 in the modem interface board as shown in Figure 19 on page 53. If the X2 jumper is in position 3-4 and if the unit ID is not set, FD12P keeps the modem carrier signal on all the time. Set the FD12P to the polling mode with the AMES 0 2 command. The host system must ask data messages by polling each FD12P.

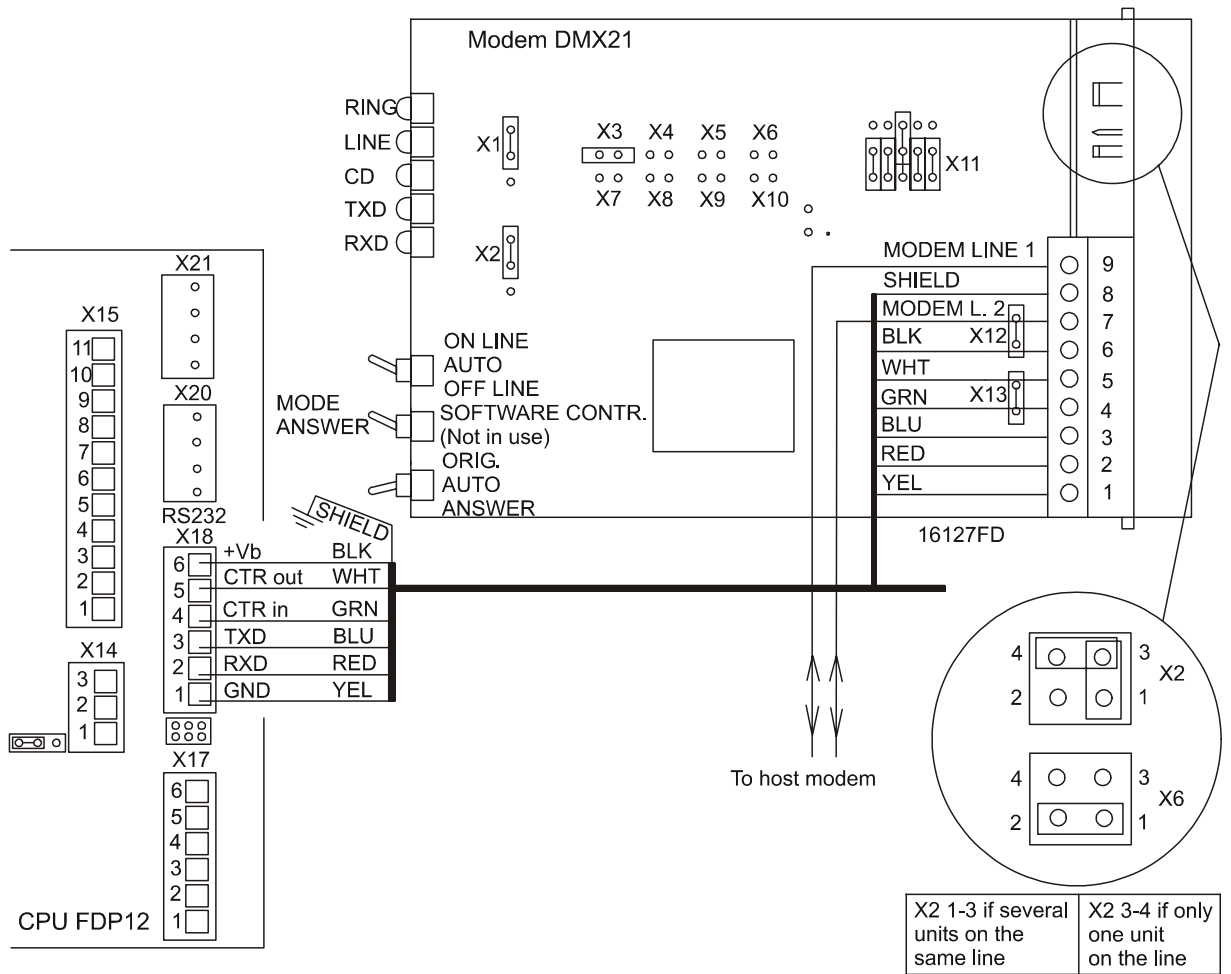

9509-012

**Figure 19 Wiring the Modem**

Usually, the modem of the FD12P operates in the answer mode, and the modem of the host computer in the originate mode. In the standard FD12P system, the S3 switch on the DMX21 board is in the DOWN position and the answer mode is selected. When the switch is in the UP position, the originate mode is selected. The transit frequencies of the DMX21 modem are presented in Table 7 below.

**Table 7 Transmit Frequencies of the DMX21 Modem Board**

	Originate Mode		Answer Mode	
TXD	0	1	0	1
CCITT	1180	980	1850	1650

## Indicators and Manual Controls

This section describes the alternatives of the indicators and manual controls available in the FD12P DMX21 modem.

### Indicators

The LED indicators of the DMX21 modem are listed and described in Table 8 below.

**Table 8 LED Indicators of the DMX21 Modem**

LED Indicator	Description
LED V16 R	Ring indicator, normally off.
LED V17 ON LINE	Normally lit when the S2 switch is in the UP position. The line, however, is permanently connected by jumper connections. The V17 LED may also be off although the modem is online. The S2 switch in the DOWN position switches the V17 LED off.
LeV18 CD	Indicates when a carrier frequency is detected. To make date interchange possible, the modems must first detect the carrier frequency.
LED V19 TxD	Transmitted data stream when the data is 1, the LED is lit.
LED V20 RxD	Received data stream. When the received data is 1, the LED is lit.

### Manual Controls

The manual controls and their positions are listed and described in Table 9 below.

**Table 9 Manual Controls of the DMX21 Modem**

Control	Position	Description
S2	UP	Line relay permanently on (recommended position).
	MIDDLE	Line relay controlled by software (switched lines).
	DOWN	Line relay permanently off.
S1	UP	
	MIDDLE	Software-readable switch (recommended position).
	DOWN	
S3	UP	ORIG mode permanently on.
	MIDDLE	ORIG/ANSWER modes under software control.
	DOWN	ANSWER mode permanently on (normally used). <sup>1</sup>

<sup>1</sup> The ORIG mode may also be used depending on the host computer modem. When they operate in the ORIGINATE mode, the modem of FD12 P should be set in the ANSWER mode and vice versa.

## Analog Transmission

For 4-20 mA analog visibility measurement only two wires are needed. Do the following:

1. Connect the voltage supply either from remote or internal supply (from  $+V_b = 12\text{ V}$  or  $+V_{bb} = 23\text{ V}$ ) to resistor  $R$  (for example, 100 ohm).
2. Connect the signal wire to screw connector X20 pin 3 "sink" at the CPU board. In the drawing, a remote voltage supply is used and the return signal is wired from pin 4 "gnd". See Figure 20 below.

For more information of the analog output port functioning and configuring, see section Analog Output Commands on page 91.

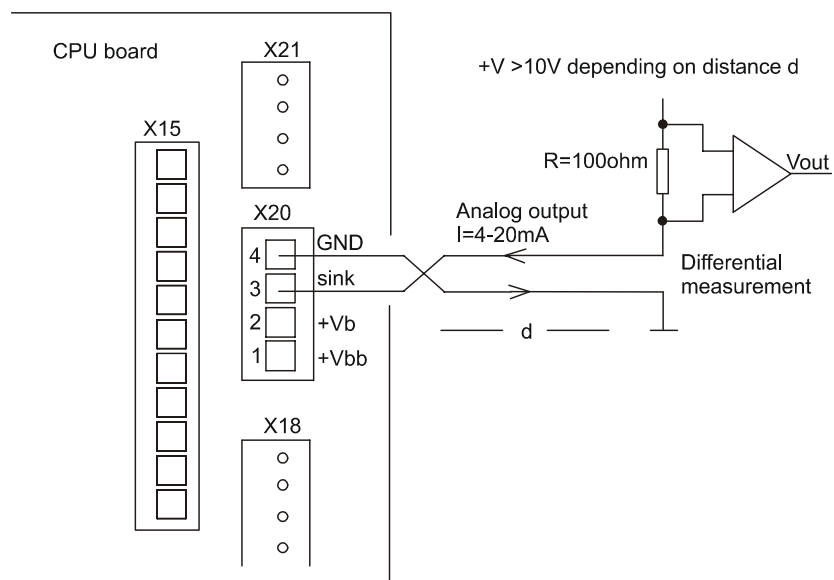

9607-007

**Figure 20** Analog Current Loop Option

## Connecting the Maintenance Terminal

Any computer equipped with a terminal emulation software or a VT100 compatible terminal with the RS-232 serial interface can be used as a maintenance terminal for the FD12P. The optional maintenance cable provides a 9-pin D-connector for the computer and a 3-pin connector for the FD12P.

To connect the maintenance terminal, do the following:

1. Disconnect the serial line screw connector or modem interfacing cable (or the RS-485) from X18.
2. Plug the maintenance cable into X18.
3. Refer to Figure 17 on page 51 (RS-232).

## Startup Testing

Before closing the cover of the electronics enclosure, a short startup must be done as follows:

1. Connect a terminal via serial line to the sensor (See sections Serial Transmission RS-232 on page 50 or Connecting the Maintenance Terminal on page 55). Set the terminal baud rate to 300 and set the data frame to contain 7 data bits and 1 stop bit, even parity.
2. Turn on the main switch at the power supply FDW13.
3. Check that the red LED on the CPU board is lit for a few seconds, after which the green LED should start blinking. If not, continue with troubleshooting.
4. After startup, the FD12P outputs:

```
VAISALA FD 12P V1.XX 19YY-MM-DD SN
```

(ID is also included, if configured.)

5. Wait for one minute and enter the command mode with the OPEN command. Check with the STA command that no hardware errors or warnings are detected.
6. Enter the automatic message mode by typing CLOSE and check that a message appears every 15 seconds in the display.

## Initial Settings

The FD12P Weather Sensor is typically interfaced to a host computer or a data logger in an automatic weather observing system. After the physical connection has been made, the communication details can be configured in the FD12P software. Suitable communication settings depend on the implementation of the whole system.

By default the sensor transmits a new ASCII data message through the serial line every 15 seconds. The user can change the interval and

message type. The sensor can also be used in a polled mode, that is, a data message is only sent when the host computer requests one with a special command. In addition, the baud rate of the serial line can be changed to a higher value. The default communications settings are listed in Table 10 below.

**Table 10 Default Communication Settings**

Setting	Default
Baud rate	300 baud (7E1)
Polled or automatic mode, message type	Automatic mode, message 2 interval 15
Sensor ID	No ID set

In multipoint communication where several sensors share the same communication line, the FD12P should be used in the polled mode and individual sensors must have distinct identifiers (ID).

The baud rate should not be changed if the optional 300-baud modem is used.

The commands for changing the default settings are listed in Table 11 below. Detailed descriptions of the commands can be found in Chapter 4 on page 59.

**Table 11 Commands for Changing the Default Settings**

Operation	Command
Baud rate selection	BAUD
Polled or automatic mode, message type setting	AMES
Sensor ID configuration	CONF

The FD12P has also several changeable parameters, which control the operation of the present weather algorithm and precipitation measurement. The factory set parameter values have been found appropriate in tests and usually do not need to be changed. However, there may be conditions where other parameter values give better results.

The commands for displaying and changing the parameters are listed in Table 12 below.

**Table 12 Commands for Displaying and Changing the Parameters**

Operation	Command
Parameter listing	WPAR
Parameter change	WSET

Local practice may require changes, especially in the precipitation intensity limits and the haze threshold value. For details, see the description of the WSET command in section WSET Command on page 73.

When the precipitation intensity and amount measurement is not factory calibrated, higher accuracy can be achieved by adjusting a scaling factor with the WSET command. The new scaling factor can be calculated by comparing the FD12P against a reference rain gauge. For details, see the description of the WSET command in section WSET Command on page 73.

## CHAPTER 4

# OPERATION

This chapter contains information needed to operate this product.

### Introduction

The FD12P Weather Sensor is a fully automatic instrument for continuous weather measurement. Normally, the FD12P Weather Sensor is either set to send a data message automatically or it is polled by a host computer. In addition, a set of user commands is provided for configuring and monitoring the system performance. These commands can be given in the command mode. See section Entering/Exiting the Command Mode on page 61.

The FD12P Weather Sensor has seven different standard message formats for data message output. The FD12P presents the weather type using the World Meteorological Organization (WMO) code table 4680 ( $W_aW_a$  Present Weather reported from an automatic weather station). Code numbers 77 (snow grains), 78 (ice crystals), and 89 (hail) are from the code table 4677 because the types are not included in the code table 4680. In addition, the United States National Weather Service (NWS) abbreviations are available. The list of NWS and WMO codes is presented in Appendix A on page 143.

### User Commands in Normal Operation

User intervention is not required in the normal operation of the FD12P Weather Sensor. Operator commands are used only in the initial set-up and during routine maintenance. Several commands are also available for troubleshooting.

When the sensor has been installed, the user may need to change some of the default settings. For details, see section Initial Settings on page 56.

Table 13 below lists the settings and the corresponding commands.

**Table 13 Settings and Corresponding Commands**

<b>Operation</b>	<b>Command</b>
Baud rate	BAUD
Polled or automatic mode, message type setting	AMES
Sensor ID	CONF
Weather algorithm parameters	WSET

Table 14 below lists the routine maintenance commands.

**Table 14 Routine Command for Maintenance**

<b>Operation</b>	<b>Command</b>
Sensor cleaning	CLEAN (optional)
Visibility calibration	CHEC, CAL
Temperature calibration	FREQ, TCAL
Weather algorithm parameters	WSET

The standard output messages contain a status character, which presents the results of the internal diagnostics to the host computer or the user. If the sensor indicates a warning or an alarm in a standard output message, the host computer or the user can obtain a detailed status report by using a special command (STA). The status report can also be polled (message 3) in place of the standard data message. Usually, the detailed status information is sufficient for locating the fault.

Table 15 below lists the status report command.

**Table 15 Status Report Command**

<b>Operation</b>	<b>Command</b>
Getting a status report	STA

## Markings Used in This Manual

The general format of the command is the following:

**COMMAND** *parl...parn* ↵

where

Command	=	An FD12P command given by the user
<i>parl...parn</i>	=	Possible parameters of the command
↵	=	Symbolizes pressing the ENTER key

### NOTE

All the command parameters are separated from each other by a space character. Every user command must be ended with ENTER, illustrated in this manual by ↵.

The system output is illustrated as Courier type font, for example,

```
BACKSCATTER INCREASED
```

## Entering/Exiting the Command Mode

Before any commands can be given to the FD12P, the communication line in the FD12P has to be assigned to the operator. Otherwise, it is assigned to automatic messages or polled communication. The user assigns the command mode with the OPEN command.

### OPEN Command

If no device identifier (*id*) is defined, type

```
OPEN ↵
```

If *id* is defined, for example as A, type

```
OPEN A ↵.
```

If *id* is defined but forgotten, type

```
OPEN ^C ↵
```

where ^ is the control key.

The FD12P answers

LINE OPENED FOR OPERATOR COMMANDS

If no input is given within 60 seconds, the FD12P closes the line automatically.

## CLOSE Command

Line can be released to automatic data messages by typing

CLOSE ↵

The FD12P answers

LINE CLOSED

## Automatic Message Sending

In the automatic (CLOSEd) mode, the FD12P sends the predefined message at selected intervals. The automatic message is selected by the AMES command.

AMES *Message\_number* *Message\_interval* ↵

where

*Message\_number*

- The valid range is 0 ... 7, refers to section Message Types on page 63.
- Selects the corresponding message. Any negative message number is converted to 0.
- If only the message number is given, the previous message interval setting is used.

*Message\_interval*

- Given in multiples of 15 seconds (= measuring interval). Therefore, intervals 15, 30, 45 ... are valid. Other intervals are converted to multiples of 15 seconds. The maximum sending interval is 255 seconds (4 minutes 15 seconds).

For example, typing

```
AMES 1 60 ↵
```

selects message number 1 to be sent once in a minute.

Messages can also be displayed in the command mode with the MES command, described in section MES Command on page 71.

## Message Types

All the data messages are of fixed length and the data is in fixed fields. Message 2 is intended to be used as the standard present weather message. The length of the status message depends on the possible alarm and warning states.

The FD12P adds frame strings to the polled and automatic messages. The content of the frame strings is presented in the following:

$$^{\text{S}_\text{H}}\text{FD id}^{\text{S}_\text{X}}\text{message body}^{\text{E}_\text{X}}\text{C}_\text{R}\text{L}_\text{F}$$

where

$\text{S}_\text{H}$	=	Start of heading (ASCII 1, non-printable character, in terminal screen typically seen as the □ mark)
FD	=	FD12P sensor identifier
	=	Space character
id	=	Unit identifier 2 characters, if ID is not defined characters space and 1 are shown
$\text{S}_\text{X}$	=	Start of text (ASCII 2, non-printable character)
$\text{E}_\text{X}$	=	End of text (ASCII 3, non-printable character)
$\text{C}_\text{R}\text{L}_\text{F}$	=	CR + LF (ASCII 13 + ASCII 10)

**NOTE**

The contents of messages 0, 1, 2, 5, 6, and 7 are illustrated as follows:

```

10  6800  110.96          <- The first row is the output.
↓↓      ↓      ↓
----- offset frequency   { Field
----- one minute average visibility { descriptions
- 1=hardware error, 2= hardware warning |
- 1= alarm 1 2= alarm 2
```

**Example with frames**

```

□FD 1□10  6800  110.96□

sHFD 1sx10  6800  110.96sxcrtF
012345678901234567890123456
```

**NUMBERS mark the character positions.**

**Message 0**

Message 0 displays only the one-minute average visibility truncated to 1990 and the offset frequency of the optical measurement hardware.

```

00  6800  126.87
----- offset frequency
----- one minute average visibility
- 1=hardware error, 2= hardware warning
- 1= visibility alarm 1, 2= visibility alarm 2
```

An example with frames is as follows:

```

□FD 1□00  6800  126.87□

sHFD 1sx00  6800  126.87sxcrtF
012345678901234567890123456
```

**Message 1**

Message 1 displays the instant precipitation type and the optical (volume) intensity. The intensity can be integrated to rain sum, but not snow.

```

00  6839 52  0.3
----- precipitation (volume) intensity, mm/h
--- instant precipitation type, 0 ... 99
----- visibility one minute average, max 50000m
- 1=hardware error, 2= hardware warning
- 1= visibility alarm 1, 2= visibility alarm 2
```

An example with frames is as follows:

```

□FD 1□00 6839 52 0.3□
%FD 1%00 6839 52 0.3%0F
0123456789012345678901234567

```

## Message 2

Message 2 is intended as the standard present weather message used in data loggers or display units and it is set as default at the factory.

```

00 6839 7505 L 52 61 61 0.33 12.16 0
-----cumulative snow
sum,0...999mm
----- cumulative water
sum,0...999mm
----- precipitation (volume)
intensity,mm/h
--- one hour present weather code, 0...99
--- 15 minute present weather code, 0...99
--- instant present weather code, 0 ... 99
---- instant present weather, NWS codes
----- visibility ten minute average, max 50000m
----- visibility one minute average, max 50000m
- 1=hardware error, 2= hardware warning
- 1= visibility alarm 1, 2= visibility alarm 2

```

An example with frames is as follows:

```

□FD 1□00 6839 7505 L 52 61 61 0.33 12.16 0□
%FD 1%00 6839 7505 L 52 61 61 0.33 12.16 0%0F
01234567890123456789012345678901234567890123456789012345

```

## Message 3

Message 3 is the same as the status message obtained by using the STA command. Refer to Table 22 on page 86 for possible error texts.

```

FD12P STATUS
SIGNAL      0.39 OFFSET      126.83 DRIFT      0.14
REC. BACKSCATTER      1281 CHANGE      -1
TR. BACKSCATTER      10.3 CHANGE      0.1
TE      2.7 VBB      19.4 VH      0.6
LEDI      5.6
P15      15.1 M15      -15.0 BGND      -0.1
AMBL      0.1 DUTY      1.6
DRI21 MEASUREMENTS
TS      1.8 DRD INST      811 DRY      915.6
HARDWARE :
OK

```

## Message 4

Message 4 is for hardware monitoring. The same data line is obtained by using the `FREQ` command.

```
0.51 126.82 0.91 15 3 5 2.7 5.6 1280 19.5 1.8 819
>FREQ
SIGNAL+  OFFSET DIST SWID MAXI OWID  TE LEDI BACKS  VBB  TS  DRD
0.59 126.83 0.91 17 2 6 2.7 5.6 1280 19.4 1.8 816
0.59 126.83 0.91 17 2 6 2.7 5.6 1280 19.4 1.8
817
```

## Messages 5 and 6

Messages 5 and 6 are for MITRAS transmissometer message emulation in VAISALA RVR systems.

An example of MES 5 is provided below:

```
%xID 1 V 1050 CV // B // S0101 CRFEx
--- <CR><LF><ETX>
-- receiver 2 status
  (two spaces)
-- receiver 1 status
-- transmitter status
-- S, status heading
----- background luminance value
  cd/m2(option)
-- B, background luminance heading
----- (contamination) compensated visibility
  (reserved, not supported by FD12P)
--- CV, compensated visibility heading
----- non-compensated visibility m
-- V, visibility heading
-- unit ID (one character only)
-- ID, start indicator
- <STX>

%xID 1 V 1050 CV // B // S0101 CRFEx
1234567890123456789012345678901234567890123
```

An example of MES 6 is provided below:

```
%xID 1 V 4550 B // S4101 CRFEx
--- <CR><LF><ETX>
-- receiver 2 status
-- receiver 1 status
-- transmitter status
-- S, status heading
----- background luminance value cd/m2
-- B, background luminance heading
----- non-compensated visibility m
-- V, visibility heading
-- unit ID (one character only)
-- ID, start indicator
- <STX>

%xID 1 V 4550 B // S4101 CRFEx
123456789012345678901234567890123
```

The status is in hexadecimal notation.

The status bits emulate the MITRAS status as shown in Table 16 and Table 17 below.

**Table 16 Transmitter Status Correspondence between MITRAS and FD12P**

BIT	MITRAS	FD12P
0	MEAS MODE	ON
1	ECON MODE	OFF
2	OPTICAL SURFACE	TRB warning or alarm
3	POWER SUPPLY	VBB (power supply)
4	HEATING	VH (lens heater current)
5	FLASH LAMP	LEDI (LED intensity control)
6	BL METER	BL meter interface (DRI21) connected
7	MEASUREM. LOOP SIGNAL	-

**Table 17 Receiver Status Correspondence between MITRAS and FD12P**

BIT	MITRAS	FD12P
0	MEAS MODE	ON
1	SPARE	
2	OPTICAL SURFACE	REC. BACKSCATTER warning or alarm
3	POWER SUPPLY	±15 V status
4	HEATING OK = OFF	
5	CALIBRATION	AMBL
6	TEST OK = OFF	
7	SPARE	

The MITRAS polling command is the following:

```
P<sp><ID><cr><lf>
```

## Message 7

Message 7 is meant mainly for aviation specific purposes. The message contents are as follows:

```
00 6839 7505 L 52 61 61 0.33 12.16 0 23.4 12345
-----background
          luminance cd/m2
----- surface temperature
----- cumulative snow sum
----- cumulative water sum
----- precipitation water intensity,mm/h
          (1 minute average)
--- one hour present weather code, 0 ... 99
--- 15 minute present weather code, 0 ... 99
--- instant present weather code, 0 ... 99
---- instant present weather, NWS codes
----- visibility ten minute average, max 50000m
----- visibility one minute average, max 50000m
- 1=hardware error, 2= hardware warning
- 1= visibility alarm 1, 2= visibility alarm 2

-RA , instant METAR weather codes

RERA , recent METAR weather (RE criteria used)
```

An example with frames is as follows:

```
□FD 1□00 6839 7505 R 61 61 61 0.33 12.16 0 23.4 //
-RA
RERA
□

shFD 1sx00 6839 7505 R 61 61 61 0.33 12.16 0 23.4 ///crF
-RAcrF
RERAcrF
excrF
```

Message 7 consists of four lines. METAR present weather codes are output on the second and third lines. These lines are not of fixed length because METAR codes can be combined in many ways. The METAR codes may also be left out but the lines of the message are always terminated by a carriage return and line feed characters.

The background luminance value displays the measured luminance in cd/m<sup>2</sup>, if the Vaisala LM11 Background Luminance Meter is attached to the FD12P (option FD12PLM11). If a day/night switch is connected to the processor board, the background luminance value displays the switch state (1 = day, 0 = night).

## Message Polling

In the polled (CLOSEd) mode, the FD12P sends a data message when the host computer transmits a polling command. The message polling mode is selected by the following command:

**AMES** *Message\_number* *Message\_interval* ↵

where

*Message\_number*

- The valid range is 0 ... 7, refer to section Message Types on page 63.
- Selects the corresponding message as the default polled message. Any negative message number is converted to 0.

*Message\_interval*

- Negative or zero interval is used to disable the automatic sending. This is used when messages are polled.

For example, AMES 0 0 ↵ selects message 0, and cancels the automatic sending.

The polling command format is the following:

```
<ENQ> FD <SP> id <SP> message_number <CR>
```

where

<ENQ> = ASCII character 05 hex  
 <SP> = ASCII character 20 hex (space)  
 id = Selected in the configuration  
 message\_ = Optional  
 number

If only one FD12P unit in on the line and no *id* is set, the command format is the following:

```
<ENQ> FD <CR>
```

When the FD12P unit number two (*id* = 2) is polled for message number 3, the command format is the following:

```
<ENQ> FD <SP> 2 <SP> 3 <CR>
```

This format is also used when several devices are on the same line. Use character 1 as the *id* if the *id* has not been set but a specific message type is polled.

The FD12P does not echo the polling character string.

The answer message format is the following:

```
<SOH> FD <SP> id <STX> text <ETX><CR><LF>
```

The *id* field always contains two characters. If only one character has been set as the *id*, the sensor will output an <SP> as the first character in the field.

When there are several devices on the same line, the polled unit turns the modem (DMX21) carrier on after it has acknowledged the request. When the carrier is switched on, additional characters will appear before the <SOH> (01 hex) character. The FD12P waits about 100 ms after turning the carrier on before it starts to send the message. When the FD12P has sent the message, it turns the carrier off. This will also generate additional characters, which have to be ignored by the host.

## FD12P Command Set

### HELP Command

The operator receives information about available commands by typing

```
HELP ↵
```

The HELP command sets are listed in Table 18 below.

**Table 18**      **HELP Command Sets**

Command	Description
OPEN	Assigns the line for operator commands
CLOSE	Releases the line for automatic messages
MES	Displays data message
AMES <i>Number Interval</i>	Automatic message (with parameters Number and Interval)
STA	Displays status
PAR	Parameter message
WPAR	Weather parameter message
PRW	Present weather message
CONF <i>Password</i>	Updates configuration
CLEAN	Sets clean references

Command	Description
CHEC	Displays average signal
CAL <i>Calibrator_frequency</i>	Calibration
CLRS	Clears precipitation sums
ACAL	Analog output calibration
TIME <i>hh mm ss</i>	Sets/displays system time
DATE <i>yyyy mm dd</i>	Sets/displays system date
BAUD <i>rate par</i>	Baud rate setting (Rate 300, 1200, 4800, 9600) (Par E(7E1) or N(8N1))
AN <i>channel</i>	Analog channel (0,1,3,8 ... 15 or ANALOG ID)
DAC <i>data</i>	(Without DATA = SWEEP)
RESET	Hardware reset by watchdog
WHIS	Present weather history
WSET	PRW reference values
DRY ON	Sets DRD dry offset
WET ON	Sets DRD wet scale
BLSC	Sets/Displays background luminance scale

## MES Command

After opening the line for operator commands (see section Entering/Exiting the Command Mode on page 61), a data message can be displayed using the MES command. There are eight messages available for different uses and they numbered from 0 to 7. Refer to section Message Types on page 63 for message type descriptions.

The command format is the following:

**MES** *Message\_number* ↵

with a valid range from 0 to 7. For example, when choosing the data message number 2, type

MES 2 ↵

## AMES Command

The AMES command defines the message, which the FD12P transmits as the automatic message or as the default polled message. Messages can also be displayed by the MES command, described in MES Command on page 71.

The format of the AMES command is the following:

**AMES** *Message\_number* *Message\_interval*

where

*Message\_number*

- The valid range is 0 to 7.
- Selects the corresponding message. Any negative message number is converted to 0.
- The message number is also the default number for the MES command and polling.
- If only the message number is given, the previous interval setting is used.

*Message\_interval*

- Given in multiples of 15 seconds (= the measuring interval). Therefore intervals 15, 30, 45 ... are valid. Other intervals are converted to integer multiples of 15 seconds. The maximum sending interval is 255 seconds (4 minutes 15 seconds).
- Negative or zero interval ignores the automatic sending. This is used when messages are polled. Refer to section Message Polling on page 69 for details.

For example, typing

```
AMES 1 60 ↵
```

selects message number 1 to be sent once in a minute.

Typing

```
AMES 0 0 ↵
```

selects message 0, and cancels the automatic sending.

The AMES command without parameters displays the current selection and it is the following:

```
AMES ↵
```

## Weather Related Commands

To display or set the weather analysis parameters and results, use the commands listed in Table 19 below.

**Table 19**      **Commands for Displaying or Setting Weather Analysis Parameters**

Command	Parameters and Results
WPAR	Weather parameter message
WSET	Prw reference values
PRW	Present weather message
CLRS	Clear precipitation sums
WHIS	Present weather history

### WPAR Command

Use the WPAR command to display the present weather analysis parameters. Typing `WPAR ↵` displays the following output:

```
WEATHER PARAMETERS
PRECIPITATION LIMIT          40
WEATHER UPDATE DELAY         6
HAZE LIMIT                    9000
RAIN INTENSITY SCALE         0.80
VIOLENT RAIN LIMIT           50
HEAVY RAIN LIMIT              8.0
LIGHT RAIN LIMIT              2.0
DRIZZLE LIMIT                 15
HEAVY DRIZZLE LIMIT          30
LIGHT DRIZZLE LIMIT           3
WARM LIMIT                    8.0
SNOW LIMIT                    5.0
HEAVY SNOW LIMIT              600
LIGHT SNOW LIMIT              1200
SNOW PELLETS LIMIT           30
SNOW GRAINS LIMIT             20
ICE CRYSTALS LIMIT            40
HAIL LIMIT                    300
DRD SCALE                     1.5
DRD DRY OFFSET                900.0
DRD WET SCALE                 0.0016
```

### WSET Command

The WSET command is used to modify the present weather analysis parameters.

The command asks for one parameter at a time, showing the parameter name and the current setting. Accept the current value by pressing ENTER. You can give a new value by typing the value before pressing ENTER.

## Type

WSET↵

and the output is as follows:

```
SET PRESENT WEATHER PARAMETERS
PRECIPITATION LIMIT ( 40 )
WEATHER UPDATE DELAY ( 6 )
HAZE LIMIT ( 9000 )
RAIN INTENSITY SCALE ( 0.80 )
VIOLENT RAIN LIMIT ( 50 )
HEAVY RAIN LIMIT ( 8 )
LIGHT RAIN LIMIT ( 2 )
DRIZZLE LIMIT ( 15 )
HEAVY DRIZZLE LIMIT ( 30 )
LIGHT DRIZZLE LIMIT ( 3 )
SNOW LIMIT ( 5.0 )
HEAVY SNOW LIMIT ( 600 )
LIGHT SNOW LIMIT ( 1200 )
SNOW PELLETS LIMIT ( 30 )
SNOW GRAINS LIMIT ( 20 )
ICE CRYSTALS LIMIT ( 40 )
HAIL LIMIT ( 300 )
DRD SCALE ( 1.5 )
WARM LIMIT ( 8.0 )
```

The parameters are described in detail below.

### Precipitation Limit

The *Precipitation limit* parameter is the threshold of accumulated particle magnitudes (in FD12P internal units) that reports the precipitation on state. The typical parameter value is 40. The smaller value represents a more sensitive operation and faster response at the beginning of an event.

### Weather Update Delay

The *Weather update delay* parameter is a time as multiple of 15 seconds, during which the instant precipitation type is not changed. The intensity may change faster.

### Haze Limit

The *Haze limit* parameter specifies the visibility threshold for reporting haze or mist. When the visibility is between 1000 m and the *Haze limit*, the FD12P will report either haze or mist depending on the air humidity.

## Rain Intensity Scale

The *Rain intensity scale* parameter is multiplied by the measured raw intensity, which gives the reported precipitation intensity (optical). The rain amount is scaled with the same coefficient because the amount is a direct integral of 15-second intensities.

The typical value for the *Rain intensity scale* is 0.8. as the optimal value is complex to determine; it depends on the optical, opto-electronic, and electronic parameters. No applicable factory calibration method has been developed yet.

The precipitation measurement can be calibrated by comparing the FD12P rain amount to measurements made with a suitable reference rain gauge. Make the comparison after a few rainfalls with 5 mm or more of total accumulated rain. A new scaling factor can be calculated using the following formula:

$$\text{Newscale} = \text{Oldscale} \times (\text{Ref\_Amount} / \text{FD12P\_Amount})$$

where

Oldscale	=	Old value of Rain Intensity Scale
Ref_Amount	=	Amount measured with the reference rain gauge
FD12P_Amount	=	Corresponding amount measured by the FD12P

## Violent Rain Limit

The *Violent rain limit* parameter defines the minimum rain intensity (mm/h), when the intensity is violent.

## Heavy Rain Limit

The *Heavy rain limit* parameter defines the minimum rain intensity (mm/h), when the intensity is heavy.

## Light Rain Limit

The *Light rain limit* parameter specifies the maximum rain intensity (mm/h), when the intensity is light. If the rain intensity is between the above heavy and light limits, it is moderate.

## Drizzle Limit

The *Drizzle limit* parameter refers to the maximum drop size (in FD12P internal units), which can be detected as drizzle. The typical value is 15, which has been found to be the optical signal from a 0.5 mm diameter droplet measured by typical FD12P hardware. The

parameter value relates to the square of droplet radius. The relationship is the following:

$$X = 240 \times R^2$$

where

X = Parameter value

R = Droplet radius

Parameter value 30 would correspond to about a 0.7-mm droplet diameter.

### Heavy Drizzle Limit

The *Heavy drizzle limit* parameter refers to the minimum number of drizzle droplets detected in 15 seconds. They must be detected before drizzle becomes heavy (dense).

### Light Drizzle Limit

The *Light drizzle limit* parameter defines the maximum number of droplets detected in 15 seconds, when drizzle is light.

### Snow Limit

The *Snow limit* parameter specifies the minimum ratio of optical precipitation intensity to surface sensor (DRD12) precipitation intensity, when the precipitation is snow. A half of this value is used for separating sleet and ice pellets.

The typical value for *Snow limit* is 5. A smaller value directs the FD12P to report more wet precipitation as snow.

### Heavy Snow Limit

The *Heavy snow limit* parameter defines the minimum visibility (m) on a two-minute average in heavy snow.

### Light Snow Limit

The *Light snow limit* parameter defines the maximum visibility (m) on a two-minute average in light snow. If snow is detected and the two-minute visibility average is between the above heavy and light snow limits, snow intensity is moderate.

### Snow Pellets Limit

The *Snow pellets limit* parameter specifies the minimum particle size (in FD12P internal units), which is detected as snow pellets. (Additional internal criteria are used before the precipitation type is determined to be snow pellets.)

### Snow Grains Limit

The *Snow grains limit* parameters refers to the maximum particle size (in FD12P internal units), which is detected as snow grains.

### Ice Crystals Limit

The *Ice crystals limit* parameters defines the maximum particle size (in FD12P internal units), which is detected as ice crystals. (Additional internal criteria are used before the precipitation type is determined to be ice crystals.)

### Hail Limit

The *Hail limit* parameters refers to the minimum particle size (in FD12P internal units), which is detected as hail. (Additional internal criteria are used before the precipitation type is determined to be hail.)

### DRD Scale

The *DRD scale* parameter is the scaling factor for the calculated intensity of the DRD12 surface sensor. The typical value for this parameter is 1.5. The value is also good for a very clean DRD12. When the DRD12 becomes dirty after some precipitation events, it becomes more sensitive, especially for light rain. Thus, a smaller value of the scale could be used.

### Warm Limit

The *Warm limit* parameter defines a more flexible, maximum snow reporting temperature limit, which is required in some areas. The nominal value is +8 °C.

## PRW Command

The Present Weather command (PRW) command, displays a verbal format message.



## System Configuration Commands

Table 20 below lists the commands that can be used to display system parameters and to edit current system configuration.

**Table 20**      **Commands for Displaying System Parameters and Editing the Current System Configuration**

Command	Description
PAR	Parameter message
CONF <i>password</i>	Update configuration
BAUD <i>rate par</i>	Set baud rate ( <i>rate</i> 300,1200,2400,4800,9600) Par E (7E1), N (8N1)
BLSC	Set/display background luminance scale

### PAR Command

The current system parameters can be displayed by using the PAR, the System Parameters, command.

When you type

```
PAR ↵
```

the system output is shown on the next page.

```
SYSTEM PARAMETERS
VAISALA FD12P V 1.83 1999-11-19 SN: 46401
ID STRING:
AUTOMATIC MESSAGE 2 INTERVAL 15
ALARM LIMIT 1 0
ALARM LIMIT 2 0
OFFSET REF 130.50
CLEAN REFERENCIES
TRANSMITTER 8.9 RECEIVER 1769
CONTAMINATION WARNING LIMITS
TRANSMITTER 1.5 RECEIVER 200
CONTAMINATION ALARM LIMITS
TRANSMITTER 5.0 RECEIVER 500
SIGNAL SCALE 1 1.485 SCALE 0 0.000
TE OFFSET 58.5
TS SCALE 1 0.058 SCALE 0 -58.969
ANALOG VISIBILITY MAX 20000 MIN 10
LINEAR MODE
ANALOG OUTPUT SCALE 1 0.143 SCALE 0 713.00
```

## CONF Command

The configuration command, CONF, is used to set or update system parameters and to adjust certain calibrations, reference values, and limits. You can limit the use of this command by protecting it with a password. New parameter values are saved in the non-volatile memory (EEPROM).

The CONF command displays the parameters one by one and asks for a new value. In most cases, the current value is shown as the default value. The parameter is not updated if the user only presses the ↵ key.

You can modify the following system parameters using the CONF command:

- *Vis Alarm Limits*
- *Offset Freq Reference*
- *Temperature TE Scale*
- *Password Characters*
- *Unit Id Characters (2)*
- *References And Limits for Contamination Monitoring*
- *Analog Output Minimum Visibility*
- *Analog Output Maximum Visibility*
- *Analog Output Lin/Log*

To prevent unauthorized change of the system parameters, a four-character password can be set at the beginning of the CONF setting. You can also modify the password then. When you do not want to set or modify the password, press ↵.

When a password has been set in the previous session, the command format is the following:

**CONF** *password* ↵

To change the password, type

**CONF** *password* N ↵ (N stands for new).

<b>NOTE</b>
-------------

You must also know the previous password.
---

When no password has been set, the command format is the following:

```
CONF ↵
```

The system response to the CONF command is presented below (The **bold** text refers to user actions.)

```
CONF. PASSWORD (4 CHARS MAX)
UPDATE CONFIGURATION PARAMETERS
UNIT ID (2 CHAR) ( 1)
SET REFERENCE PARAMETERS ( 25.9)
TE ( 127.48) Y
OFFSET
OFFSET REFERENCE UPDATED
ALARM LIMIT 1 ( 1000)
ALARM LIMIT 2 ( 200) 300
ALARM LIMIT 2 UPDATED
TRANSMITTER CONTAMINATION
LIMITS
WARNING LIMIT ( 1.0) 1.5
WARNING LIMIT UPDATED
ALARM LIMIT ( 5.0)
RECEIVER CONTAMINATION LIMITS
WARNING LIMIT ( 100)
ALARM LIMIT ( 500) 600
ALARM LIMIT UPDATED
ANALOG OUTPUT MODE
0 = LINEAR 1 = LN ( 0)
ANALOG OUTPUT RANGE
MAX VISIBILITY ( 10000)
MIN VISIBILITY ( 50)
END OF CONFIGURATION
```

The questions asked by the system are described below.

First the system asks for a new password:

```
CONF. PASSWORD (4 CHARACTERS MAX)
```

This question is asked when there is no valid password or the existing password is updated. If updating is requested by the *N* parameter and an empty line is given for an answer, the password is removed. Otherwise, the user gives a new password to the system.

The system asks the following:

```
UPDATE CONFIGURATION PARAMETERS
UNIT ID (2 CHAR)( 1)
```

If the FD12P unit is named by one- or two-character ID codes, the OPEN and POLLING commands use it as a parameter. The ID code is

also included in the data message heading. ID 1 is used as a default in the message heading if no other ID is given. The current ID can be removed by pressing " - " as an answer to the question.

In the multidrop configuration, where several FD12 Weather Sensors are on the same communication line, the units are differentiated by the ID.

The next CONF parameters are hardware- or system-dependent. They can be changed from the factory set values for better performance or maintenance purposes. The example configuration session is explained in the following.

The single point calibration of the TE backup temperature measurement can be done by giving the temperature.

```
SET REFERENCE PARAMETERS
```

```
TE ( 25.9 )
```

The default value is the current temperature. If it is not correct, a new value must be typed as the answer. The new value is used to correct the internal TE scaling factor. The TE temperature is used as a backup in FD12P. The temperature is used in the visibility measurement to control the precipitation effect correction algorithm. Snow and rain have a different kind of effect on the scattering signal when it is used for the visibility calculation.

The currently measured offset value (not a parameter) is shown in the brackets (see next page).

```
OFFSET ( 127.48 ) Y
```

```
OFFSET REFERENCE UPDATED
```

After receiving Y as an answer, the system accepts the offset frequency to be the reference parameter for hardware monitoring. The parameter value is further compared with the current value to detect drift or other failure in the optical signal measurement electronics.

The visibility alarm limits are checked. Limit 1 is expected to be higher than Limit 2. The limit values are expressed in meters.

```
ALARM LIMIT 1      ( 1000 )
ALARM LIMIT 2      ( 200 ) 300
ALARM LIMIT 2      UPDATED
```

In the above example, alarm Limit 2 receives a new value, 300 m. When the visibility now weakens below Limit 2, then the data message (0 to 2) data status is set to 2. The visibility alarm is not shown in the status message.

The backscatter/contamination control is done by comparing the current values of backscatter signal with the reference values given with the CLEAN command. The limits given here are limits for the change in backscatter signals.

```
TRANSMITTER CONTAMINATION LIMITS
WARNING LIMIT      ( 1.0) 1.5
WARNING LIMIT      UPDATED
ALARM LIMIT        ( 5.0)
```

The transmitter values are expressed in volt (V). The measurement range is 0 to 13 V, where 0 V is a blocked lens. The limit value is given as a positive value although the signal becomes smaller when contamination increases.

A contamination change of 5 V represents about a 10 % decrease in the transmitter's lens transmittance (as also does the same increase in the visibility indication).

```
RECEIVER CONTAMINATION LIMITS
WARNING LIMIT      ( 300)
ALARM LIMIT        ( 500) 600
ALARM LIMIT        UPDATED
```

The receiver values are expressed in hertz (Hz). The measurement range is from 0 to 10000 Hz, where 10000 Hz is a blocked lens. A contamination change of 500 Hz represents about a 10 % decrease in the receiver's lens transmittance.

The analog output mode and visibility range are set last. In the logarithmic mode, the minimum visibility must be different from 0 as LN(0) is not defined.

```
ANALOG OUTPUT MODE
0 = LINEAR 1 = LN ( 0)
ANALOG OUTPUT RANGE
MAX VISIBILITY     ( 10000)
MIN VISIBILITY     ( 50)
END OF CONFIGURATION
```

## BAUD Command

The baud rate and communication type can be changed by typing following the operator command:

**BAUD** *value communication\_type*

The baud rates are 300, 1200, 2400, 4800, and 9600. The communication types are E (7E1) and N (8N1).

The new value is saved in EEPROM and it is used also after reset or power up. The default baud rate set at the factory is 300 baud (7E1). Defining the communication type is optional. It does not change if the baud rate is changed. Other baud rates than 300 baud are not allowed with the DMX21 modem.

The BAUD command displays the current baud rate and communication type. For an example, see the following:

```
BAUD RATE: 300 E71
```

## BLSC Command

The Vaisala LM11 Background Luminance sensor can be connected to the FD12P for ambient light measurement. Each LM11 sensor has an individual scaling coefficient, which is defined at the factory. The scaling coefficient is written on a label in the LM11 sensor. This coefficient should be configured to the FD12P for correct scaling of the measured background luminance values.

The BLSC command is used to set or display the background luminance scale.

When you type

```
BLSC↵
```

it displays the current background luminance scale.

When you type

```
BLSC Scaling_factor ↵
```

it sets the new background luminance scale.

If the LM11 is not connected, the scaling factor should be negative. Value -1.0 has been set at the factory as the default value. If a positive value is used, the sensor expects a signal from the LM11.

For an example, see the following:

```
>blsc
BL SCALE  -1.000
>blsc 10.4
          BL SCALE  10.400
```

If a day/night switch is connected to the serial line control input on the FDP12 processor board, the FD12P can read the switch state and report it as a background luminance value of 1 (day) or 0 (night). The FD12P firmware will read the switch if the background luminance scaling factor is set to 0.

## Maintenance Commands

The maintenance commands are listed in Table 21 below.

**Table 21** Maintenance Commands

Command	Description
STA	Displays status.
CAL <i>Calibrator_frequency</i>	Calibration.
TCAL	Temperature measurement calibration.
CLEAN	Sets clean references.
CHEC	Displays average signal.
FREQ	Displays internal signals.
DRY ON	Sets DRD12 dry offset.
WET ON	Sets DRD wet scale.
AN CHANNEL	Analog channel (0,1,3,8 ... 15 or ANALOG ID).

### STA Command

The STA command displays the results from the built-in test system as a status message. Message 3 gives the same status message as the STA command.

When you type

```
STA ↵
```

the system output is the following:

```

SIGNAL      0.39 OFFSET      126.83 DRIFT      0.14
REC. BACKSCATTER      1281 CHANGE      -1
TR. BACKSCATTER      10.3 CHANGE      0.1
TE      2.7 VBB      19.4 VH      0.6
LEDI      5.6
P15      15.1 M15      -15.0 BGND      -0.1
AMBL      0.1 DUTY      1.6
DRI21 MEASUREMENTS
TS      1.8 DRD INST      811 DRY      915.6
HARDWARE :
OK

```

An asterisk (\*) before a value indicates an exceeded limit.

In the end, there are verbal comments on the combined errors detected. These comments can be one or many of the following listed in Table 22 below.

**Table 22 Hardware Error Texts**

Error text	Description
BACKSCATTER HIGH	The receiver or transmitter contamination signal has increased more than the ALARM limit given in the configuration.
TRANSMITTER ERROR	The LEDI signal is more than 7 V or less than -8 V.
+15 V POWER ERROR	The receiver/transmitter power is less than 14 v or more than 16 V.
OFFSET ERROR	The offset frequency is zero (cable is disconnected).
SIGNAL ERROR	The signal frequency is less than 50 % of the offset frequency.
RECEIVER ERROR	Too low signal detected in the receiver backscatter measurement.
DATA RAM ERROR	The error is in RAM read/write check.
EEPROM ERROR	This is an EEPROM checksum error.

The hardware warning texts are listed in Table 23 below.

**Table 23 Hardware Warning Texts**

Warning text	Description
BACKSCATTER INCREASED	The receiver or transmitter contamination signal has increased more than the WARNING limit selected in the configuration.
TRANSMITTER INTENSITY LOW	The LEDI signal is less than -3 v.
RECEIVER SATURATED	The AMBL signal is less than -9 v.
OFFSET DRIFTED	The offset has drifted more than $\pm 5$ Hz from the reference value.
LENS HEATER OFF	No current flowing to lens heaters.
DRI21 NOT	The DRI21 board cannot be detected.

Warning text	Description
CONNECTED	
TS SENSOR ERROR	The DTS14B measurement is off limits.
DRD12 ERROR	The DRD12 analog signal is close to zero.
LUMINANCE SENSOR ERROR	The LM11 signal is zero (not checked if the BLSC is negative).
TE SENSOR ERROR	Box temperature sensor TE measurement is off limits.
VISIBILITY NOT CALIBRATED	The visibility calibration coefficient has not been changed from the default value.

## CAL Command

The CAL command is used to calibrate the visibility measurement. The calibration is done by using opaque glass plates with known scatter properties.

The command type is the following:

```
CAL Calibrator_signal_value ↵
```

Type, for example, the following:

```
CAL 985 ↵
```

The calibrator signal value is printed on the labels of the glass plates. Typically, the signal is close to 1000 Hz. The FD12P calculates a new scaling factor and stores it in the non-volatile memory (EEPROM). Refer to section Calibration on page 119 for instructions.

## TCAL Command

The TCAL command is used to calibrate the sensor crossarm temperature (TS) measurement. Only 0 °C temperature is important in its accuracy because it is used in the identification of freezing rain.

When you type

```
TCAL ↵
```

the command displays the current scaling factors.

Without a parameter, the command displays the current scaling factors and current TS.

When you type

```
TCAL TS ↵
```

the command initializes the two-point calibration sequence, where two temperatures must be simulated.

When you type

```
TCAL TS DTS14B_temperature ↵
```

a single-point calibration to the TS is made. That is, the scaling factor TS 0 is adjusted by the command routine.

The following command

```
TCAL TS 0.0 ↵
```

makes a zero calibration, if the temperature sensor DTS14B is in an ice bath or otherwise at a temperature of 0 °C .

The following command

```
TCAL TS 0.0581 -59.0 ↵
```

sets both scaling factors.

The system output is as follows:

```
DRI TEMPERATURE SCALES  
  
TS 1 0.0581 TS 0 -59.0000 TS 2.8
```

## **CLEAN Command**

The CLEAN command has no parameters and it is used to set the clean references for contamination control. This command is given during maintenance procedures after cleaning the lenses or after replacing the transmitter or receiver board.

When you type

```
CLEAN ↵
```

the FD12P output is as follows:

```
CLEAN REFERENCES  
TRANSMITTER 12.0  
RECEIVER 1402  
UPDATED
```

## CHEC Command

The CHEC command is used in the visibility calibration procedure to display the two-minute average signal frequency in hertz. The command has no parameters.

The display is terminated by pressing ESC. Pressing any other key will pause the display. In the beginning, the eight-location buffer is filled with the first value. The buffer is used to calculate the average

When the FDA13 calibrator is installed, the value displayed in the message should be the same as printed on the calibrator glass plate. In clear air the value should be near zero.

When you type

```
CHEC ↵
```

the output is the following:

```
SCALED FREQUENCY AVE (2 MIN)
999.9938
999.9880
>
```

## FREQ Command

The FREQ command is for hardware monitoring. Message 4 gives the same data line as the FREQ command.

An example of the output is the following:

```
>freq
SIGNAL+  OFFSET DIST SWID MAXI OWID  TE LEDI BACKS  VBB  TS  DRD
      0.03 129.79 1.00  4  2  4  24.4  5.3 1303 19.5 23.1 900
      0.03 129.79 1.00  4  2  4  24.4  5.3 1303 19.5 23.1 900
```

A new line is printed every 15 seconds. The command output is terminated by pressing the ESC key. The first line is a title line with the signal names.

## DRY and WET Commands

The DRY and WET commands are used to check and adjust the operation of the Rain Detector DRD12 analog signal measurement.

The DRY command is used to set the dry signal end of the DRD12 signal normalization calculation.

When you type

```
DRY ↵
```

the output is, for example, the following:

```
DRD DRY OFFSET 915.6
```

The DRY OFFSET value must be between 850 and 980 when the DRD12 hardware operates normally. The DRY command shows this parameter. The parameter is set by the DRY ON command.

When you type

```
DRY ON ↵
```

the WET command without a parameter shows the scaling factor that normalizes the DRD12 signal change from the dry state to the wet state to 1.00. A typical value is 0.0015. An example is shown in the following:

```
WET ↵
```

```
DRD WET SCALE 0.00169
```

The WET ON command is used to set the parameter. The DRD12 measuring surfaces must be coated with a wet cloth or immersed in water, when the WET ON command is given. An example of the command is given below:

```
WET ON ↵
```

## **AN Command**

The AN command can be used continuously to display the selected analog monitor channel. The channel ID can be used as a parameter, instead of the channel number. Thus, the AN AMBL command is the same as AN 12.

The message consists of the raw binary number from the A/D converter and the corresponding scaled and filtered value.

## Type

AN AMBL ↵

WAITING FOR MULTIPLEXER

ANALOG INPUT,	AMBL
118	0.1
119	0.3

# Analog Output Commands

## Analog Output Calibration

The DAC output voltage is converted to current, 0 to 22 mA unscaled. This current is then software-calibrated to give 4 mA at the minimum visibility and 20 mA at the maximum visibility. The minimum and maximum visibility values are set in the configuration session. A hardware error is indicated by 0 mA.

The ACAL command sets two-bit values, 4000 and 800, to the digital-to-analog converter. The corresponding currents measured by a multimeter must be given as answers to the questions asked in the commands. The analog output scaling factors, which define the bits/mA relation, are then calculated by the software. The scaling factors are Scale 0 and Scale 1. The FD12 calculates them as follows:

$$\text{Scale 0} = 4 \times ((4000 - 800) / (\text{high current} - \text{low current}))$$

The bit value that gives 4 mA. Scale 1 depends on the mode.

In linear mode:

$$\text{Scale 1} = \text{bits}16\text{mA} / (\text{maximum vis} - \text{minimum vis})$$

In logarithmic mode:

$$\text{Scale 1} = (\ln(\text{max vis}) - \ln(\text{min vis})) / \text{bits}16\text{mA}$$

$$\text{bits}16\text{mA} = (3200 / (\text{high current} - \text{low current})) \times 16$$

When you type

ACAL ↵

the command gives, for example, the following output:

```
MEASURED CURRENT (mA)    22.16
MEASURED CURRENT (mA)    4.52
```

## Data Scaling

The FD12 scales the visibility value to a binary number for the DAC (= DACBITS) so that the minimum visibility corresponds to the 4 mA-calibrated value and maximum visibility to the 20 mA-calibrated value.

In linear mode:

$$\text{DACBITS} = (\text{visibility} - \text{min visibility}) \times \text{scale 1} + \text{scale 0}$$

In logarithmic mode:

$$\text{DACBITS} = (\ln(\text{visibility}) - \ln(\text{min visibility})) \times \text{scale 1} + \text{scale 0}$$

If visibility is less than minimum visibility then

$$\text{DACBITS} = \text{bits}_{4\text{mA}} = \text{scale 0}$$

If visibility is more than maximum visibility then

$$\text{DACBITS} = \text{bits}_{20\text{mA}}$$

## Hardware Check

The DAC bit value from 0 to 4095 can be given as a parameter. The value does not change until you press ESC. When the DAC command has been given without a parameter, the analog output sweeps slowly from 0 to maximum and from 0 until you press the ESC key.

For example:

DAC 800 ↵

## Other Commands

### TIME Command

The TIME command is useful for maintenance purposes.

To display the current system time, type

```
TIME ↵
```

The system output is, for example, the following:

```
10:11:12
```

To set the time, use the following command:

```
TIME hh mm ss ↵
```

where

```
hh = Hours  
mm = Minutes  
ss = Seconds
```

**NOTE**

Reset the time after a power break.

### DATE Command

The DATE command is used to display the current date.

Type

```
DATE ↵
```

To set a new system date, use the command:

```
DATE yyyy mm dd ↵
```

where

```
yyyy = Year  
mm = Month  
dd = Day
```

## **RESET Command**

The RESET command makes the hardware reset by the watchdog circuitry.

The command format is the following:

```
RESET ↵
```

## CHAPTER 5

# FUNCTIONAL DESCRIPTION

This chapter gives a functional description on the product.

### General

The FD12P Weather Sensor is an optical sensor that measures visibility (meteorological optical range, MOR), and precipitation intensity and type. The FD12P measures visibility using the forward scatter measurement principle. Light scatters from particles whose diameter is in the order of magnitude of the light wavelength. The amount of scatter is proportional to the attenuation of the light beam.

Larger particles behave as reflectors and refractors and their effect on the MOR must be handled separately. Usually, these particles are precipitation droplets. The FD12P optical arrangement allows for individual droplets to be detected from rapid signal changes. The FD12P software calculates the precipitation intensity by analyzing the amplitudes of these changes. This intensity estimate is proportional to the volume of the precipitation droplets.

The optical signal also contains some information about the precipitation type but not enough for reliable identification. Additional information is needed, especially in conditions where the precipitation is very light or the weather is windy. As the extra parameter, the FD12P measures an estimate of the water content of precipitation with the DRD12 rain detector. In rain, the water equivalent and the volume are equal. However, in snow the optical volume estimate is about ten times larger. This difference of approximately one decade is used to discern between rain and snow.

## Optical Measurement

### Optical Arrangement

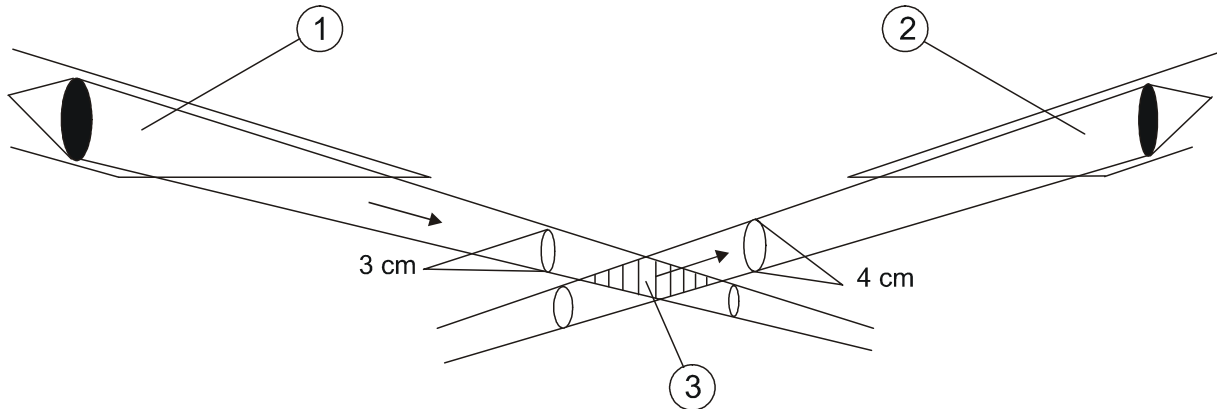

0110-185

**Figure 21** FD12P Optical System

The following numbers refer to Figure 21 above:

- 1 = FDT12 transmitter
- 2 = FDR12 receiver
- 3 = Sample volume

The FD12P measures light scattered at an angle of  $33^\circ$ . This angle produces stable response in various types of natural fog. Precipitation droplets scatter light in a different manner than fog. Thus, their contribution to visibility must be analyzed separately. The FD12P can detect and measure precipitation droplets from the optical signal and use this information in processing the scatter measurement results.

The FD12P has a small sample volume of about 0.1 liters (see Figure 21 above). This enables independent particles to be measured even at quite heavy precipitation intensities. The signal levels from even the smallest droplets can also be detected.

### FDT12B Transmitter Unit

The transmitter unit consists of an infrared LED, control and triggering circuits, LED intensity monitor, backscatter receiver, and analog multiplexer.

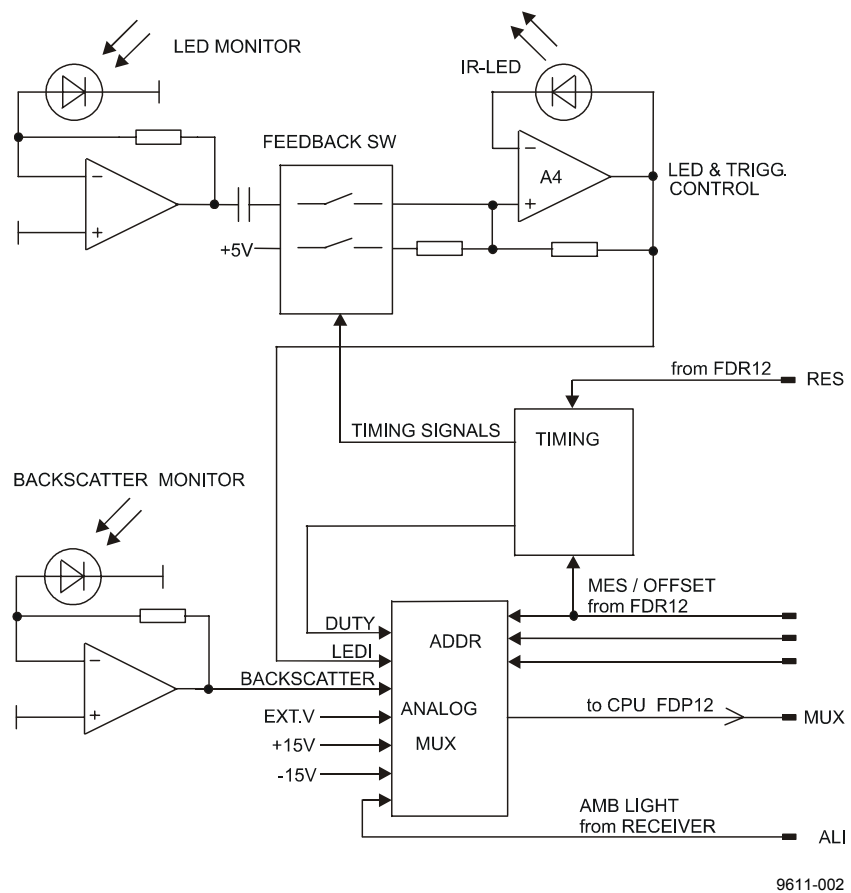

**Figure 22 FDT12B Transmitter Block Diagram**

The transmitter unit electronics pulses the IR-LED at a frequency of 2.3 kHz. One PIN-photodiode monitors the transmitted light intensity. The transmit level measurement is used to automatically keep the LED's intensity at a preset value. The "LEDI" feedback voltage is channeled through the analog multiplexer to the CPU for monitoring.

The feedback loop compensates for temperature and aging effects of the light-emitting diode. On the other hand, the active compensation slightly accelerates the LED aging. For this reason, the initial LED current is set to a value, which guarantees several years of maintenance-free operation.

A reset pulse (RES) from the FDR12 Receiver synchronizes the IR-LED timing with the receiver's lock-in amplifier. The CPU can also delay the transmitter firing for a special out-of-phase measurement. This feature is used in measuring the internal noise level (offset) of the circuitry.

An extra photodiode measures the light scattered backwards from the lens, other objects, or contaminants. This signal as well as several internal signals are monitored via MUX-line.

The CPU board supplies only one voltage  $V_b = 10 - 13 \text{ V}$  for both the transmitter and receiver. This is used for heating the lenses, for the transmitter LED heating and for producing both  $+5 \text{ V}$  digital and  $\pm 15 \text{ V}$  analog supplies. The  $\pm 15 \text{ V}$  supply is located on the FDT12B board.

## FDR12 Receiver Unit

The Receiver Unit consists of a light receiver, preamplifier, voltage to frequency converter, backscatter measurement light source LED, and some control and timing electronics.

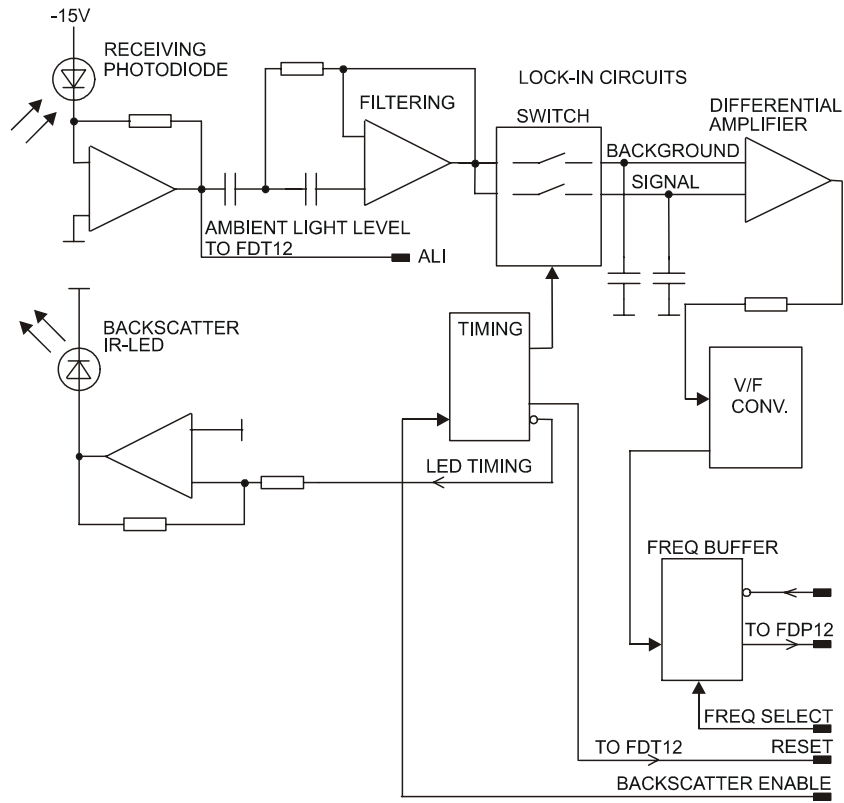

9611-003

**Figure 23 FDR12 Receiver Block Diagram**

The receiving PIN photodiode senses the transmitted light pulses scattered from the aerosol particles. The signal voltage is filtered and detected by a phase-sensitive, lock-in amplifier synchronized with the transmitter.

The lock-in circuits take two samples of the background level and one sample of the active signal level while the transmitter LED is lit. The difference between the sampled voltages is amplified and then converted into frequency.

The frequency signal is buffered by a differential line driver and sent to the CPU board for accurate counting.

An ambient light level as high as 30 kcd/m<sup>2</sup> does not influence the detection of the photo diode, neither does it saturate the A4 pre-amplifier. The Ali signal (proportional to the ambient light) is led to the CPU for monitoring.

An extra IR-LED is needed for backscatter or contaminant measurement. The light level is sampled and converted into frequency using the same method of detection described with the scattering signal measurement.

## Additional Measurements

### General

The FD12P includes the DRD12 Rain Detector for estimating the water content of precipitation and the DTS14B Temperature Sensor for measuring the sensor crossarm temperature (TS). Both additional sensors are measured using the DRI21 Interface Board, which is coupled on the FD12P PICOBUS.

### DRI21 Interface Board

The DRI21 is a Vaisala general-purpose sensor interface with several analog and digital input channels. One of the DRI21 temperature input channels (Pt100) is used to measure the crossarm temperature (DTS14B). One 10-bit analog input channel is used to measure the DRD12 analog signal. In addition, the DRI21 controls the DRD12 heating and reads the rain ON/OFF status.

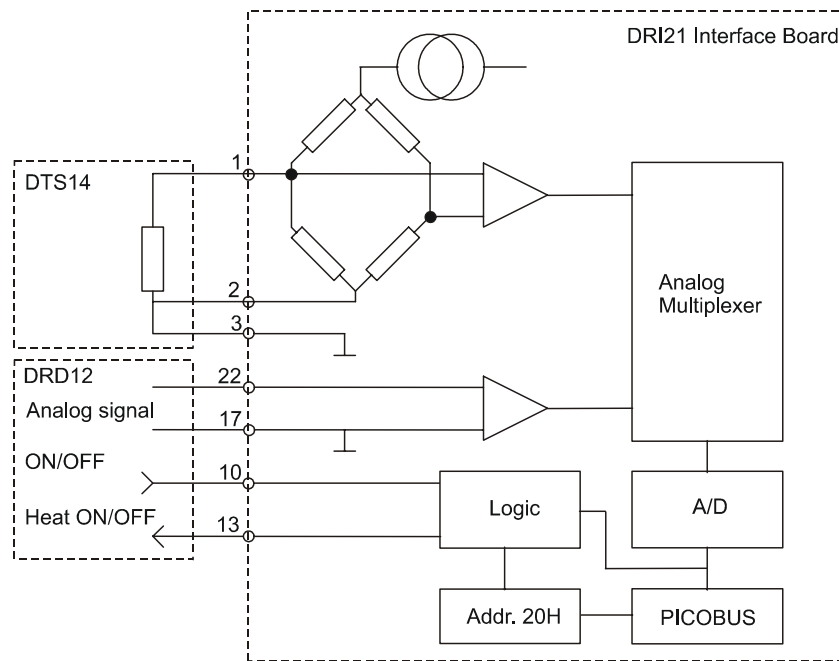

9807-031

**Figure 24 DRI21 Block Diagram in the FD12P Application**

## DRD12 Rain Detector

The DRD12 analog signal is proportional to the water amount on the sensing surfaces. Water on the DRD12 changes the capacitance of the sensor elements. The capacitance of the elements controls the output frequency of an oscillator. This frequency is amplified and also converted into a voltage signal for direct analog measurement. With dry surfaces, the DRD12 outputs about 3 V and with totally wet surfaces 1 V. Refer to Figure 29 on page 104, section DRD12 Signal Processing on page 104.

A droplet detector monitors the voltage signal. When a new droplet hits the DRD12 sensing surface, the voltage changes rapidly and the detector circuit reacts. The detector triggers a delay circuit, which controls the precipitation ON/OFF output. When new droplets are detected often enough, the delay circuit output will stay constantly on.

The voltage signal is measured once a second by an analog channel of the DRI21 interface board. In addition, the precipitation (ONN/OFF signal) is read with a digital input.

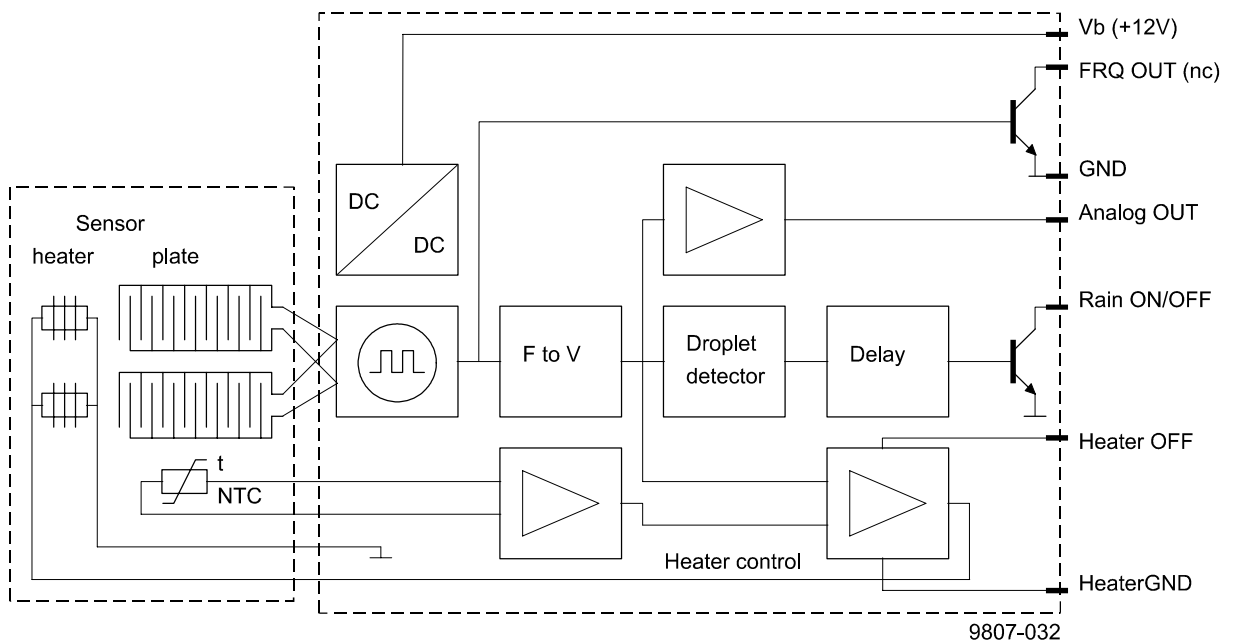

**Figure 25 DRD12 Block Diagram**

The DRD12 sensing surfaces are heated by heating elements built into the surfaces. The heating power varies automatically (by built-in temperature control), but it can be switched off with a digital control signal. When the heating is off, the surfaces become extremely sensitive to all moisture in the air.

## DTS14B Temperature Sensor

The DTS14B is a PT100 temperature sensor with a special mechanical construction. The temperature is measured once a minute using the DRI21 temperature channel.

The DTS14B is attached to the sidewall of the mast to achieve direct thermal contact with the mast surface. The temperature (TS) is used to select the default precipitation type and to separate freezing rain from non-freezing rain.

## FDP12 Control Unit

The FDP12 Control Unit consists of the microprocessor, communication interface, memory, frequency measurement circuitry, watchdog, monitoring circuitry, and digital-to-analog converter.

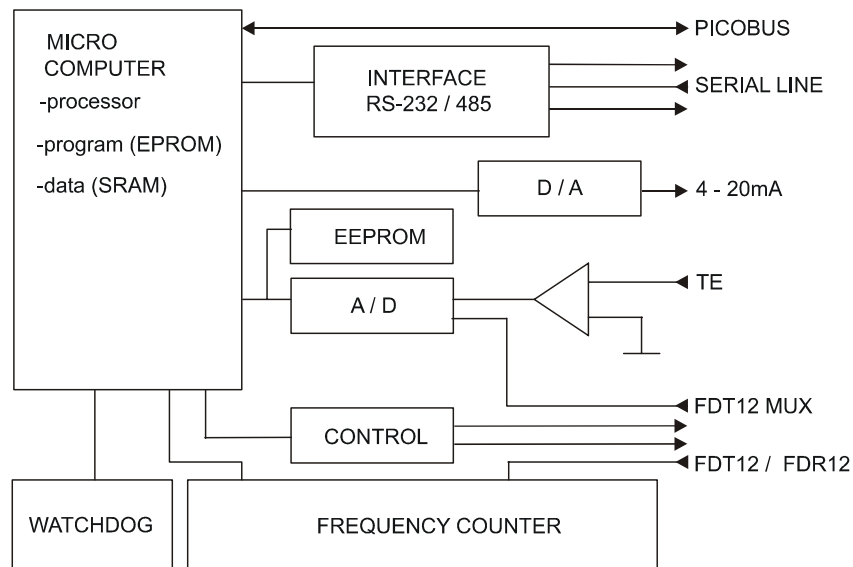

9611-004

**Figure 26 FDP12 Control Unit Block Diagram**

The controller is based on an Intel® 8031 microprocessor. Besides data acquisition and internal controlling, the FDP12 takes care of communication through the RS-232 serial port. The alternative RS-485 interface allows a simple method for multiple FDP12P Weather Sensors to communicate on the same line. The PICOBUS interface facilitates a connection to a number of Vaisala peripheral units. The memory includes a 512-kbit EEPROM for program code and a 256-kbit static RAM for data and working parameters. For configurable parameters, there is a serial non-volatile EEPROM.

The special frequency measurement circuitry measures the optical signal that is converted into frequency in the Receiver Unit FDR12.

The watchdog circuit monitors the +5 V level as well as the system operation creating a hardware reset when necessary. For internal monitoring of analog signals, the CPU board contains an 8-bit A/D converter. Along with Mux-signals from the crossarm, the lens heating current and the ambient temperature are sampled. The Control unit further includes an accurate, 12-bit D/A converter, which can be configured for two-wire, 4 to 20 mA-current output.

# Measurement Signal Processing

## Optical Signal Processing

The software running in the FDP12 CPU controls the measurement hardware and reads the data samples. The FDP12P measures in 15-second cycles as follows:

- 10 s signal frequency and analog monitoring voltages are measured
- 1 s receiver backscatter frequency
- 4 s offset frequency (internal noise level)

The hardware outputs an optical measurement sample every 8 ms (on the average). The raw samples are first classified by frequency to get a signal distribution. The distribution is then analyzed with a proprietary algorithm, which selects a part of the distribution for signal average calculation (Figure 27 below). The difference of the signal average and offset average is used in the visibility calculation.

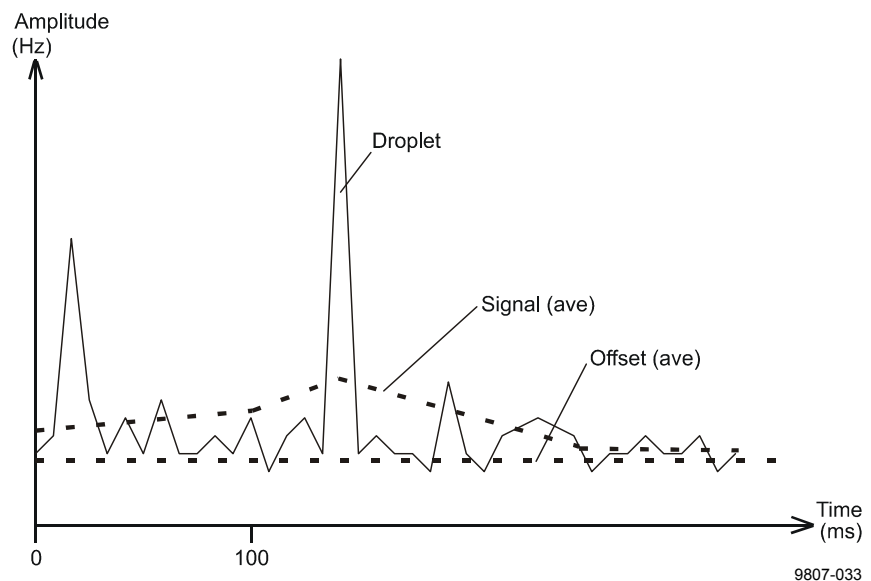

**Figure 27 Optical Raw Data (in Rain)**

Precipitation causes peaks in the optical signal. These peaks are analyzed by calculating an amplitude change distribution from the samples. Because the signal amplitude is proportional to the droplet size, the amplitude change distribution can be interpreted as the droplet size distribution. The droplet size distribution is an important parameter in determining the form of precipitation.

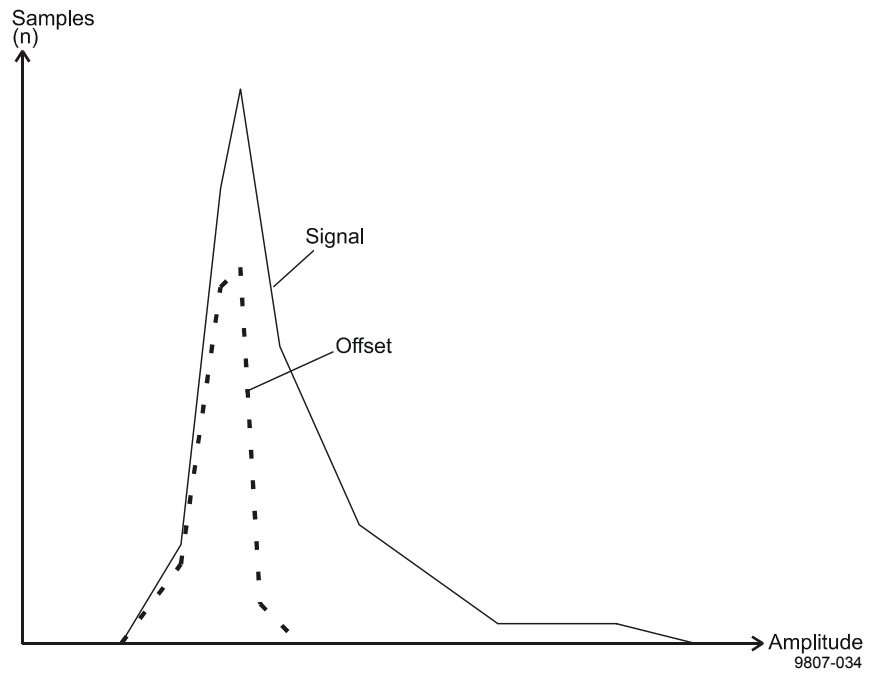

**Figure 28 Optical Signal Amplitude Distribution (in Rain)**

## DRD12 Signal Processing

The DRD12 output voltage is measured once a second by the DRI21 interface board. With dry surfaces, the voltage is approximately 3 V and drops when the sensing elements become wet (Figure 29 below).

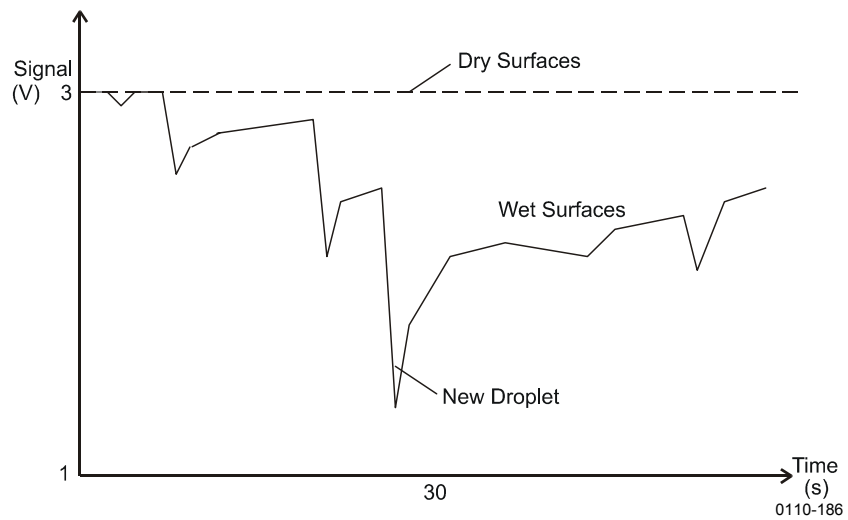

**Figure 29 DRD12 Surface Signal (Heavy Rain Beginning)**

The software normalizes the measured signal and then estimates the precipitation intensity using an empirical algorithm. The estimate is proportional to the amount of water on the DRD12 surfaces. The signal normalization is calibrated at the factory with dry and completely wet surfaces.

When the heating of the sensor elements is switched off, the sensor elements become very sensitive to ambient moisture. If the relative humidity of the air is more than about 70 % , the surfaces produce a measurable signal even with no precipitation. This is used as an estimated humidity measurement in the FD12P. The estimated humidity is used to separate between haze and mist.

As the FD12P can detect the beginning of precipitation from the optical signal, the DRD12 heating can be turned off when there is no precipitation. The software disconnects the heating after one hour from the previous precipitation detection. When precipitation or moisture is detected again, the heating is turned on for at least one hour.

## Algorithm Description

### Visibility

The optical signal analysis calculates the difference of the measurement signal and offset averages for the visibility algorithm. The difference value (frequency) is given as a parameter to a calibrated transfer function. The transfer function converts frequency into visibility (MOR). A signal of one hertz corresponds to a visibility of about 4500 m and 100 Hz about 150 m. The exact form of this transfer function has been defined using an accurate transmissometer (Vaisala MITRAS) as a reference.

The instantaneous (15 s) visibility values are averaged to get one- and ten-minute average output values. The averages are calculated from extinction coefficient values to better emulate human observations. The extinction coefficient ( $\sigma$ ) is defined as follows:

$$\sigma \text{ (1/km)} = 3000/\text{MOR (m)}$$

If the signal level is less than 0.23 Hz (visibility over 15 km), the FD12P uses extra filtering in the one-minute average MOR value. The filter function is the following:

$$\text{MOR} = (4 \times \text{signal} + 0.1) \times \text{NEW MOR} + (1 - (4 \times \text{Signal} + 0.1)) \times \text{OLD MOR}$$

where

OLD MOR = The previous average value

NEW MOR = A new instantaneous value

The lower the signal value, the less the new instantaneous value is included in the average. The minimum influence of the new sample is 10 %. This filtering reduces noise in the output values.

## Detecting Precipitation

The precipitation onset detection is based on measuring the signal peaks caused by precipitation droplets. The peak amplitudes that are detected during 10 minutes are summed. When the sum exceeds a threshold value, the sensor will indicate precipitation. The threshold value is the *Precipitation limit* parameter and can be changed by the operator.

In addition to the optical detection, the DRD12 ON/OFF signal is used in lowest precipitation intensities. The DRD12 is also used for some cross-checking of the optical detection.

The precipitation ending is detected when the summed optical signal amplitudes decrease below another, lower threshold value. The summing interval depends on the detected precipitation intensity. Typically, the FD12P will detect precipitation ending within a few minutes but in low intensity precipitation the detection time may reach 10 minutes.

## Precipitation Intensity

The light scattering from a precipitation particle is proportional to the volume of the particle. This proportionality is quite stable for rain because the droplets are all quite spherical. In solid precipitation, the shape of particles varies but is proportional to the average volume of the particles.

The optical value of the precipitation intensity is calculated from the distribution data of signal change and then scaled by multiplying with the *Rain intensity scale*, which is an adjustable parameter. The optical intensity value is proportional to the volume of the detected particles.

The DRD12 data is used to calculate another estimate of the precipitation intensity. This intensity is calculated from low pass and high pass filtered, one-second samples. The intensity is scaled with the *DRD scale* parameter. For normal operation in liquid precipitation, the scaled DRD12 intensity estimate should be higher than the optical intensity.

In snow, the DRD12 intensity is proportional to the water content of the snow. Due to undercatch, however, the values are often lower than the real water content. Also, different types of snow particles have characteristic behaviors on the warm sensing surfaces.

The precipitation intensity in the output messages is based on both the optical and capacitive measurements. In liquid precipitation the optical intensity is reported as such. When frozen precipitation is detected, the FD12P multiplies the optical intensity with a scaling factor to get an estimate of the water equivalent intensity. This scaling factor is calculated from the DRD12 and optical intensities. New intensity estimates are calculated every 15 s and averaged to get the one-minute intensity value, which is shown in the output messages.

## Precipitation Accumulation

The FD12P calculates the accumulation of water (including the water content of snow) and snow. The water sum is automatically reset when it reaches 99 mm and the snow sum at 999 mm. There is also a command for forced resetting by the operator or the system host computer.

Two methods are used in calculating the water sum. In rain, the optical intensity values are directly scaled to sum increments and added to the accumulated sum. In other types of precipitation, an internal scaling factor is used to get the water increment. The scaling factor is calculated from optical and DRD12 intensities.

The snow sum is accumulated from the optical intensity when snow is detected. The snow sum is only a coarse estimate of the thickness of snow. In a shorter period, the accumulated snow value is a reasonable measure of the new snow on the old snow.

# Present Weather

## Precipitation Types

The ratio of the optical intensity and the DRD12 intensity estimates is the key factor used in the precipitation type decision (see section Precipitation Intensity on page 106). Some filtering is used in calculating intensity ratio to get the parameter that is used in the type finding procedure. The *Weather delay* parameter is also used to eliminate unrealistically quick changes in the precipitation type. The sensor surface temperature (TS) is used in selecting the default precipitation type. Above *Warm limit* (+8 °C), the "default" precipitation type is rain. Below -5 °C it is snow and between -5 °C and *Warm limit* (+8 °C) it is unknown (P or 40).

In some areas, a more flexible snow reporting temperature limit is required. The *Warm limit*, which is the upper limit for reporting snow, is a user-definable parameter with the nominal value of +8 °C. The parameter can be defined between +4 °C and +8 °C. Changing the limit temperature affects the discrimination of the following parameters:

- Snow and hail if the ratio of optical and DRD intensity is over the *Snow limit* value.
- Rain&snow and Rain when the intensity ratio is between one and *Snow limit*.

If this temperature limit is set higher (towards +8 °C), the FD12P reports snow and rain&snow more often (but not above this limit temperature).

If the temperature limit value is set lower (towards +4 °C), the default precipitation rain is reported more often.

The precipitation code P (unknown type) is selected in cases where the precipitation intensity (optical) is very low and the intensity ratio appears to indicate liquid precipitation below or solid precipitation above 0 °C.

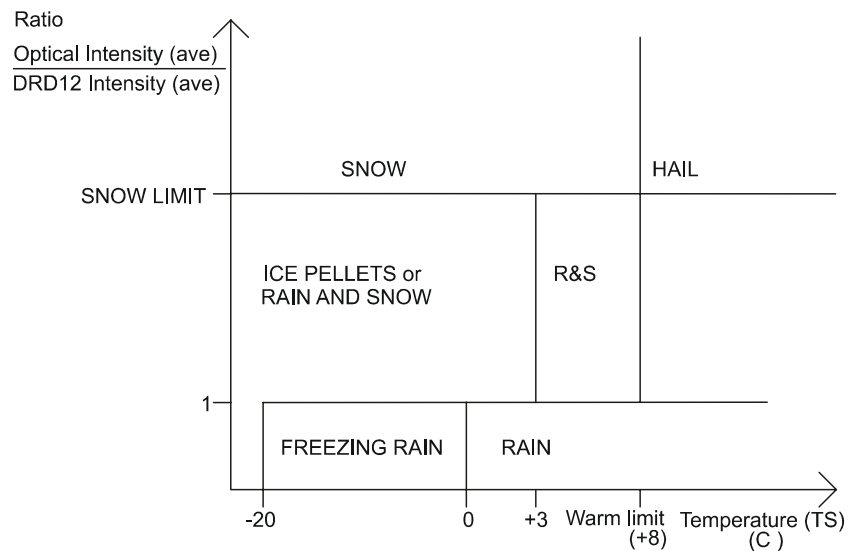

0201-092

**Figure 30 Precipitation Type Determination Principle**

The precipitation types can be divided into four main categories:

- Liquid precipitation
- Frozen precipitation
- Mixed precipitation
- Unknown precipitation

The types and their detection criteria are listed below.

#### Liquid Precipitation

In liquid precipitation, the optical and the DRD12 intensities are near each other, or the DRD12 intensity is higher. Rain and drizzle are separated by the highest peak signal (largest droplet). If liquid precipitation is detected below 0 °C (TS), it is indicated as freezing rain or freezing drizzle (ZR, ZL).

#### NOTE

The FD12P freezing precipitation detection is based on the practical definition of "rain (or drizzle) freezing on surfaces", not on detecting supercooled water.

- a. Rain: If the maximum droplet size is bigger than the *Drizzle limit*, the precipitation type is rain. The *Light rain limit* and *Heavy rain limit* are (approximately) the two-

minute average intensity limits in mm/h used to set the rain intensity type.

- b. Drizzle: Drizzle consists only of small droplets. The maximum droplet size allowed for drizzle is set by the *Drizzle limit* parameter. The *Light drizzle limit* and *Heavy drizzle limit* are the number of droplets in 15 s (average) that are used to determine the drizzle intensity. The intensity ratio (optical/DRD12) must be similar to that of rain.

**NOTE**

By definition, drizzle cannot be identified only by its size, but also by its origin (stratus cloud). The FD12P reports the instant weather code by the size information only. The 15-minute weather code in the FD12P report is drizzle, when at least ten minutes of only drizzle precipitation has been observed. The one-hour code is generated by the majority principle.

### Frozen Precipitation

Precipitation is frozen, if the ratio of optical intensity measurement to DRD12 is high.

- a. Snow: For snow, the intensity ratio (optical/DRD12) must be larger than the *Snow limit* parameter and crossarm surface temperature (TS) less than +8 °C (warm limit).
- b. Snow grains: For snow grains, the droplet signal size must be less than the *Snow grains limit* in size. Also the DRD12 intensity must be very small as the small snow grains easily bounce off the sensing surfaces.
- c. Snow pellets: Snow pellets are bigger than snow grains, but also cause very little signal on the DRD12. The *Snow pellets limit* sets the minimum of the biggest particle detected within a period of about two minutes.
- d. Ice crystals: Ice crystals are even smaller than snow grains. The *Ice crystals limit* sets the maximum particle size for ice crystals. The ice crystals are identified from the snow grain class by size. Almost no signal is detected from the DRD12.
- e. Hail: In principle, the intensity ratio is very high for hail because hail is not melted by the DRD12 surfaces. In practice, there is usually heavy rain with hail, which makes the hail detection a little uncertain. *Hail limit* sets the minimum particle size that is required for hail.

### Mixed Precipitation

The FD12P reports either rain and snow (WMO codes 67 and 68) or ice pellets (WMO codes 74, 75, and 76) when the intensity ratio is between one and *Snow limit*. The intensity is determined by estimating the water equivalent intensity and using the rain intensity limits.

- a. Ice pellets: Ice pellets is reported if the sensor crossarm temperature (TS) is below +3 °C and the maximum droplet size in internal units is less than 50.
- b. Rain and snow: Rain and snow is reported when the TS is below +8 °C (warm limit) and the criteria for ice pellets are not met (see above).

### Unknown Precipitation

Precipitation type is unknown in the following cases:

- When the default value is shown.
- When the TS is between -5 °C and +8 °C (warm limit).
- Before enough data is available for better analysis.
- When intensity is very low.
- When the intensity ratio is not reliable.

### Visibility Types

When precipitation is not detected, the weather type is determined from visibility. The visibility types for FD12P can be divided into two main categories:

- Fog
- Haze and mist

The visibility types and their detection are listed below.

#### Fog

Fog codes are reported when there is no precipitation but the visibility is less than 1 km in an average of 10 minutes. The fog trend is calculated from the one-hour data. The average of the latest and earliest 20 minutes the data are calculated. The change in these averages determines the trend. Code 20 is reported, when fog has been reported during the preceding hour but visibility is now better than 1 km and no fog patch detection is on.

- a. Fog patches: Fog patches (code 31) are detected from rapid changes in visibility across the one-kilometer fog limit. If the visibility of the one-minute average is more than twice or less than half of the two-minute average, then the internal patch indicator is set for about 30 minutes.
- b. Thinner fog: Fog is reported to become thinner (32) if (latest 20-minute average - earliest 20-minute average) > 0, and the difference is greater than 30 % of the earliest 20-minute average.
- c. Stable fog: Fog has been stable (33) if the *Absolute* (latest 20-minute average - earliest 20-minute average) is less than 20 % of the lower average visibility.
- d. Thicker fog: Fog is reported to become thicker (34) if (latest 20-minute average - earliest 20-minute average) is less than zero and the difference is more than 30 % of the new 20-minute average.

### Haze and Mist

If no precipitation is detected, a visibility code is generated. The HAZE code (04) is used when the DRD12-estimated, relative humidity is low and the visibility during the 10-minute average is less than the *Haze limit*. If the estimated humidity is high, the MIST code (10) is used instead of HAZE. If the estimated humidity is low and the visibility during the 10-minute average is less than 1000 m, then code 05 (smoke, dust, or sand) is used.

When visibility increases above  $Haze\ limit \times 1.2$ , the FD12P will report CLEAR (code 00).

### Weather Classes

The weather classes are continuous, showers, or intermittent.

The weather class is:

- Continuous, when there are less than two clear (no precipitation) periods during the preceding hour, the precipitation is continuous.
- Showers or intermittent, when there are more than two clear periods during the preceding hour in the precipitation, the weather type is intermittent.

However, if more than 30 minutes has elapsed from the last detected precipitation, the PRECIPITATION DURING THE PRECEDING HOUR code is used.

## Weather Code Selection

The FD12P presents the weather type using the World Meteorological Organization (WMO) code table 4680. Some code numbers have been adopted from code table 4677 as these codes are not included in table 4680. Precipitation type is also reported using the United States National Weather Service (NWS) abbreviations. The complete list of the WMO and NWS codes used in the FD12P is presented in Appendix A on page 143. The FD12P outputs present weather data also in the METAR present weather codes (code table 4678).

The weather type is selected every 15 seconds using the principles described earlier. The instant weather will be selected from the 15-second types according to the WEATHER DELAY number of samples by majority occurrences. The instant type is reported using both the NWS and WMO codes.

For the 15-minute and one-hour WMO weather codes, the latest one hour of instant precipitation types is stored in a buffer. The last 15-minute and one-hour parts of this table are then analyzed. The number of each precipitation type in the buffer is counted.

The counts are stored in a table in decreasing order by the code value (that is, the highest SYNOP code number first). This table is then analyzed from top down by adding the counts together until a minimum sum is obtained. The code number associated with the last added count is the 15-minute or one-hour WMO code. The minimum sum is different for the 15-minute code and the one-hour code.

## Applications

In the SYNOP group  $7W_aW_aW_1W_2$ , code  $W_aW_a$  is for weather at the observation time, and  $W_1$  and  $W_2$  are for weather after the last main observation (00, 06 ...). The FD12P codes are directly intended to be used for  $W_aW_a$ . The automatic weather station will generate  $W_1$  and  $W_2$ .

The (automatic) weather station that uses the FD12P data, can in many cases also use other weather parameters to select from the three codes from the FD12P or even correct them. For example, the humidity

measurement can be used to select between smoke, fog, mist, and haze.

The 15-minute code might be a good selection for  $W_aW_a$ . The one-hour values can then be used for  $W_1$  and  $W_2$  coding. Drizzle should not be reported until all the three codes show a drizzle type. This prevents the small droplets at the beginning and end of a shower or in intermittent rain to be reported as drizzle.

Code table 4680 does not separate between intermittent precipitation and showers. The FD12P data combined with the ceilometer data would make it possible to identify showers. The extra processing should be done in the automatic weather station software.

## Internal Monitoring

### Built-in Tests

Extensive, built-in tests are included in the FD12P operation. Various voltages are measured and corresponding alarm and warning limits are checked. Optical contamination of both the transmitter and the receiver is continuously monitored by measuring the backscattered light. For this purpose, an additional transmitting LED is installed in the receiver.

The software generates alarms, if visibility is less than the given limits. The FD12P generates warnings of suspected faulty hardware. If a fatal hardware failure is detected, visibility data is not output (it is substituted with `////`). A status message displays the cause of the error in status bits and the analog output is set to zero (0).

Built-in tests include a memory test, analog monitoring, and signal measurement monitoring. The results of the monitoring measurements are displayed in volts or hertz depending on their origin.

The program operation is monitored by the watchdog circuitry. If the circuit is not triggered in about two seconds, it will do a hardware reset.

Normal operation is indicated by the green LED blinking once every second. The yellow LED is on when the FD12P measures the visibility signal.

During the offset measurement, the yellow LED is off. In normal operation, the red LED is off.

## Memory Tests

After resetting, the FD12P tests and clears its SRAM data memory. It indicates an error by the red LED blinking. After 50 blinks, the FD12P tries to start the program anyway. Usually, this causes a watchdog reset, if the SRAM is really faulty.

The data SRAM test is also done continuously in the background in normal operation. If an SRAM error is detected, the watchdog resets the system

The checksum of the parameter memory (EEPROM) is calculated and checked for test. An error in the checksum is fatal (visibility is output as `////`). The cause is displayed in the status message.

The EEPROM checksum is calculated and checked during every updating of saved parameters.

## Signal Monitoring

The FD12P measures signal, receiver backscatter, and offset as frequencies in about eight-millisecond samples. As the measuring times are 10 s, 1 s, and 4 s correspondingly, they must have different numbers of samples in a batch. The FD12P checks that the frequencies are not zero and signal sample count is bigger than the offset sample count.

Errors in signal or offset are fatal and the data is set to `////`.

The offset drift is monitored separately. The reference offset frequency is given in the configuration session. If the drift is more than 2.5 Hz, the software generates a warning.

## Hardware Monitoring

A four-channel, analog-to-digital converter with an eight-channel multiplexer is used to measure some signals and various voltages from the hardware. The STA command displays the internal monitoring values. For more details on troubleshooting, see section Values for Internal Monitoring on page 137.

## Contamination Monitoring

The FD12P monitors both the transmitter and receiver contamination by measuring the backscattered signal. The CLEAN command is used to set the clean reference values of the backscatter signals. The deviation of the backscatter signal from the clean values is proportional to the contamination on the lenses.

The alarm and warning limits are given in the configuration session. If the alarm limit is exceeded, data is set to // and an alarm is generated. The measured values are used only for warnings and alarms. No compensation for the visibility signal is calculated.

Transmitter backscatter is measured by an analog circuit using the transmitter LED as a light source. Its identifier is TRB in the status message. The TRB is smaller for higher backscatter signals. Receiver backscatter is measured with the signal receiver using an additional, controlled LED as a transmitter. The result is in hertz. It is bigger when more light is scattered back (REC. BACKSCATTER).

## CHAPTER 6

# MAINTENANCE

This chapter describes the overall maintenance of the product.

## General

No initial calibration of the FD12P is needed because the sensor has been calibrated at the factory. The periodic maintenance of the FD12P Weather Sensor includes:

- Cleaning the transmitter and receiver lenses and hoods.
- Cleaning the DRD12 Rain Detector.
- Visibility calibration check and calibration if needed.
- Calibration of the DTS14B Temperature Sensor.

Before any commands can be given to the FD12P, the communication line must be opened. Open the communication line by typing the following:

```
OPEN ↵
```

The FD12P answer is as follows:

```
LINE OPENED FOR THE OPERATOR
```

The line can be released to automatic messages by typing the following:

```
CLOSE ↵
```

For details, see Chapter 4 on page 59.

## Cleaning

### Cleaning Lenses and Hoods

The lenses of the FD12P transmitter and receiver units must be relatively clean to obtain reliable results. Dirty lenses give too high visibility values. Clean the lenses every six months or more often depending on the conditions (for example, if there are roads nearby).

Use the STA command for monitoring the system performance.

Usually, a data message is announced if there are some warnings. Clean the lenses when the following warning appears:

BACKSCATTER INCREASED

To clean the lenses, do the following:

1. Moisten a soft, lint-free cloth with isopropanol alcohol and wipe the lenses. Be careful not to scratch the lens surfaces. The lenses should dry up indicating that the lens heating is functioning.
2. Check that the hoods and lenses are free of condensed water or ice and snow deposits.
3. Wipe the dust from the inner and outer surfaces of the hoods.
4. After the optical surfaces are properly cleaned, type

CLEAN ↵

**NOTE**

It is not necessary to give the CLEAN command always after the cleaning. Choose the STA command and check only that the BACKSCATTER CHANGE value of both the receiver and the transmitter is close enough to zero (set to zero by the previous CLEAN command).

### Cleaning DRD12 Rain Detector

The Capacitive Rain Detector DRD12 should be cleaned every six months or more often depending on the conditions.

To clean the rain detector, do the following:

1. Clean the DRD12 rain detector carefully with a soft, lint-free cloth moistened with a mild detergent. Be careful not to scratch the surface.
2. Check that the detector and the windshield are free of ice and snow deposits.

## Calibration

### General

The FD12P has been calibrated at the factory. Normally, the FD12P needs no recalibration as long as the circuit boards are not changed or there is no call for warnings and alarms. The circuit boards need no hardware calibration.

A periodic check every year is recommended. The user checks the visibility calibration using the FDA13 calibration kit. If the check shows less than a  $\pm 3\%$  change, recalibration is not recommended as the change is within the repeatability of the calibration procedure.

If any mechanical damage changes or weakens the optical measurement path, that is, either the receiver or the transmitter heads or the crossarm supporting them, recalibration is needed. If the receiver unit (FDR12), transmitter unit (FDT12B), or the CPU unit (FD12P) is changed, both visibility and contamination measurements need recalibration.

Also calibrate the DTS14B Temperature Sensor once a year.

### Visibility Calibration

Calibration is checked and adjusted with the FDA13 calibration kit. The kit consists of a blocking plate and two opaque glass plates with known scatter properties. The CHEC and CAL commands are used in the procedure. The calibration procedure checks the zero scatter signal and the very high scatter signal. The zero signal is obtained using a blocking plate and the high signal using opaque glass plates.

When the visibility measurement is calibrated, visibility should be better than 500 m. Calibration is not recommended to be carried out in heavy rain or in bright sunshine. However, light rain is of no harm.

When the calibrator is used in precipitation, the error will be proportional to the area of the scatter plates, which are covered by droplets. Make sure that this area is negligible compared with the total area. Bright sunlight shining on the calibrator plates will increase noise in the scatter measurement and make the CHEC command output less stable. If calibration needs to be carried out in bright daylight, we recommend that the crossarm be turned so that sunlight intensity on the calibrator plates is minimized (that is, the plates are parallel to the sunrays).

## Calibration Check Procedure

Clean the lenses before the calibration. Check the cleaning procedure in section *Cleaning Lenses and Hoods* on page 118. Check also the condition of the opaque glass plates and clean them if needed.

To check the calibration, do the following:

1. For blocking the light path, place the blocking plate near either of the lenses, preferably near the receiver.
2. Wait for 30 seconds.
3. Give the CHEC ↵ command. Then wait at least two minutes. The signal value must be between  $\pm 0.1$  Hz. If it is not, there may be a hardware error. Check the connectors.
4. Remove the blocking plate and terminate the CHEC command by pressing the ESC key.

To install the calibrator, do the following:

1. The calibrator clamp is permanently installed. If the clamp is not installed or the old FDA12 calibrator is used, install the calibrator clamp in the middle of the transducer crossarm. The correct place is marked by two grooves on the crossarm. Refer to Figure 31 on page 122. Do not tighten the clamp bolts, the clamp needs to be adjusted later.
2. Fasten the opaque glass plates to the tie rod. The labels with signal values should face outwards. Take note of the signal value printed on the plates because it is needed during the following steps.
3. Attach the calibrator to the clamp, tighten the rod knob. Position the calibrator plates by lifting or lowering the tie rod. The transmitter and receiver should point to the middle of the glass

plates. In the correct position, the upper edges of the plates are at the same level with the receiver and transmitter hood tips (see Figure 31 on page 122). Tighten the clamp bolts.

**NOTE**

Take a 30-cm ruler or equivalent and place it between the hood tips. Then lift the glass plates until they touch the ruler. Tighten the clamp bolts. Leave the calibrator clamp in place for the next calibrations. Extra clamps can be purchased as optional items.

4. Move away from the optical path, and wait for 30 seconds.
5. Give the `CHEC ↵` command.
6. After two minutes read the displayed signal.
7. The signal value must be close to the one printed on the plates. If the difference is less than 3 %, the calibration is correct. If not, continue with the calibration procedure.
8. Terminate the `CHEC` command by pressing the `ESC` key.

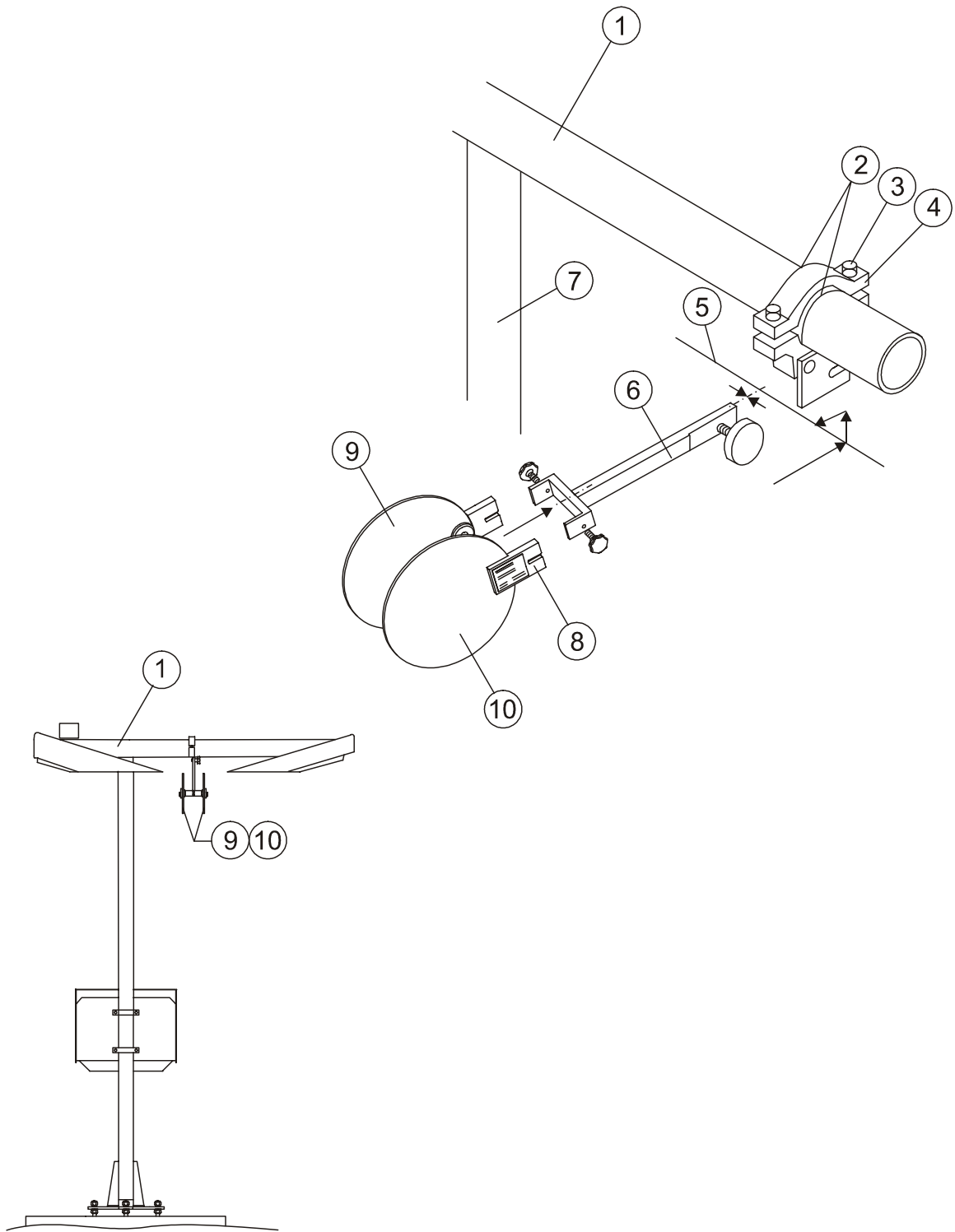

0201-087

**Figure 31 Assembling the FDA13 Calibrator**

The following numbers refer to Figure 31 on page 122:

- 1 = Crossarm
- 2 = Grooves
- 3 = M8 x 40 DIN912, 2 pieces
- 4 = Calibrator clamp
- 5 = Center of crossarm
- 6 = Tie rod
- 7 = Pole mast
- 8 = Label
- 9 = Left opaque glass plate
- 10 = Right opaque glass plate

## Calibration Procedure

If calibration is needed according to the calibration check (see section Calibration Check Procedure on page 120), follow the instructions below. The opaque glass plates are installed on the crossarm as described in the previous paragraph.

To perform calibration according to the calibration check, do the following:

1. Give the `CAL calibrator signal value ↵` command, for example, `CAL 985`.

The calibrator signal value is printed on the labels of the glass plates. Typically the signal is close to 1000 Hz. The FD12P calculates a new scaling factor and stores it in the non-volatile memory (EEPROM).

2. Type `CHEC` to learn the new scaling factor that should be equal to the calibrator signal value. If the difference between the new scaling factor and the factory calibrated one is more than 20 %, the `CAL` command will be ignored. Check the FD12P and the calibrator for hardware or mechanical errors.

If optical units FDT12B or FDR12 have been replaced, the new scaling factor might change more than 20 % from the original scaling factor value and thus, the `CAL` command is ignored. In this case, use the `FCAL` command (factory calibration) during the calibration procedure.

## Calibrating the DTS14B Temperature Sensor

Calibration of the DTS14 Temperature Sensor is recommended to be carried out once a year. For the sensor accuracy, only 0 °C temperature is important as this temperature is used to identify freezing rain. The TCAL command is used for the calibration of the surface temperature (TS) measurement.

For the calibration, prepare an ice bath into a thermos flask and remove the DTS14 sensor from the mast.

Remove the holder from the mast in the following way:

1. Open the fixing screw fully (part 3).
2. Push the screw head to the hole with your finger.
3. Slide the holder downwards as long as it goes.
4. Pull the holder and sensor away from mast hole.
5. Open the screw holding the DTS14 and pull the sensor out of the holder.
6. Hang a thermos flask with a S-shaped hook to the hole for example.
7. Put the DTS14B temperature sensor into the ice bath.
8. To see the current scaling factors and current TS, give the `TCAL ↵` command. Then give the `FREQ ↵` command. Wait for five minutes to allow the measurement stabilize. If the TS is  $0.0^{\circ}\text{C} \pm 0.1^{\circ}\text{C}$ , adjustment is not necessary. Otherwise, continue with the calibration procedure.
9. Terminate the command by pressing the ESC key.
10. Give the `TCAL TS 0.0` command. The command makes the zero calibration, if temperature sensor DTS14 is at  $0^{\circ}\text{C}$  temperature. Give the `FREQ` command and wait again to see that the new TS value is correct.
11. Terminate the command by pressing the ESC key.
12. After calibration, fix the DTS14 to the sensor holder and mount the holder to the mast.

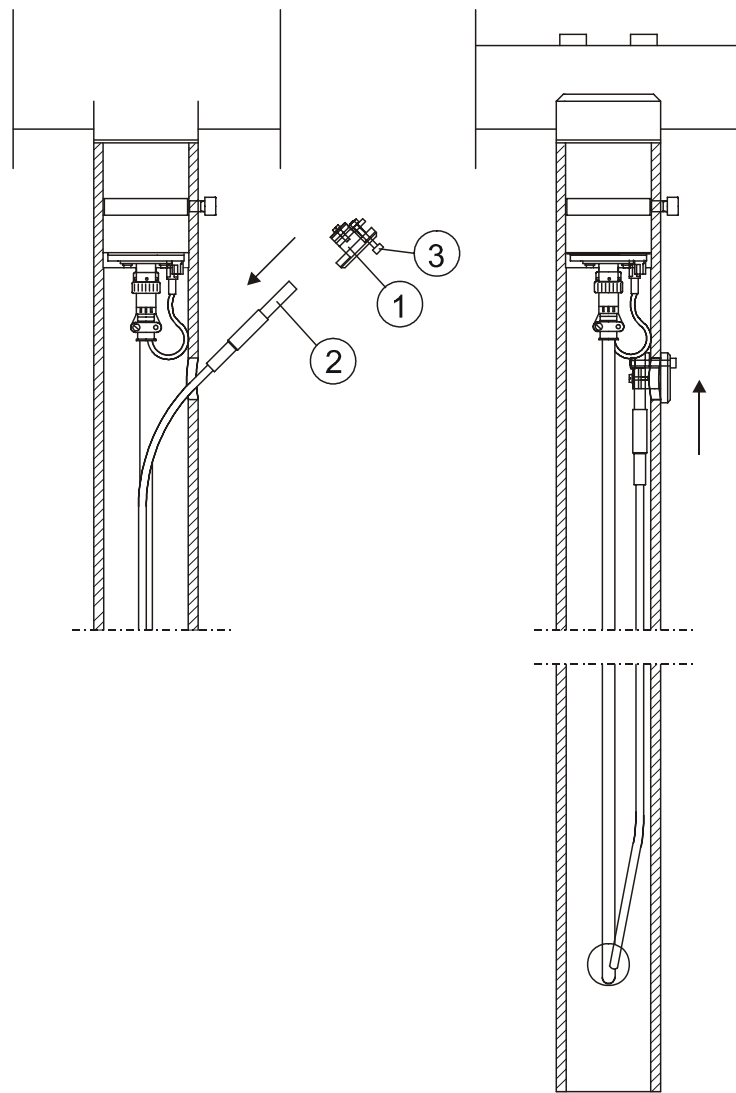

0201-088

**Figure 32 DTS14 Sensor Holder Assembly to Mast**

The following numbers refer to Figure 32 above:

- 1 = Sensor holder
- 2 = DTS14
- 3 = Fixing screw

## Removing and Replacing

This section describes in detail how to remove and replace the optical units, the FDT12B Transmitter, FDR12 Receiver, and the Rain Detector DRD12. You can remove the units when you suspect that malfunction of the FD12P is caused by faults in the optical units or the rain detector.

### Removing and Replacing Optical Units

**WARNING**

The equipment contains dangerous voltage of 230 VAC.

**CAUTION**

Servicing the equipment must be performed by qualified personnel.

To remove the unit, do the following:

1. Remove the cover at either end of the crossarm by loosening the four screws holding the cover. Use the Allen key for removing the screws.
2. Remove the black, round flange that covers the optical unit by pulling the screw in the middle of the flange. See Figure 33 on page 127.
3. Loosen the three-hexagon socket locking bolts with the 5-mm, T-handle Allen key until the optical unit is loose.
4. Disconnect the ribbon cable connector from the unit. Take note of the position of the optical unit by looking from the lens side.
5. Pull the receiver/transmitter unit carefully out of the hood tube. If a thin metal piece comes out when removing the unit, set it back to the tube end. The purpose of the metal piece is to hold the unit in the right place.

Inspect the condition of the FDT12B and FDR12 optical units visually. The circuit board test points of the FDT12B and FDR12 units are described in Appendix C on page 151.

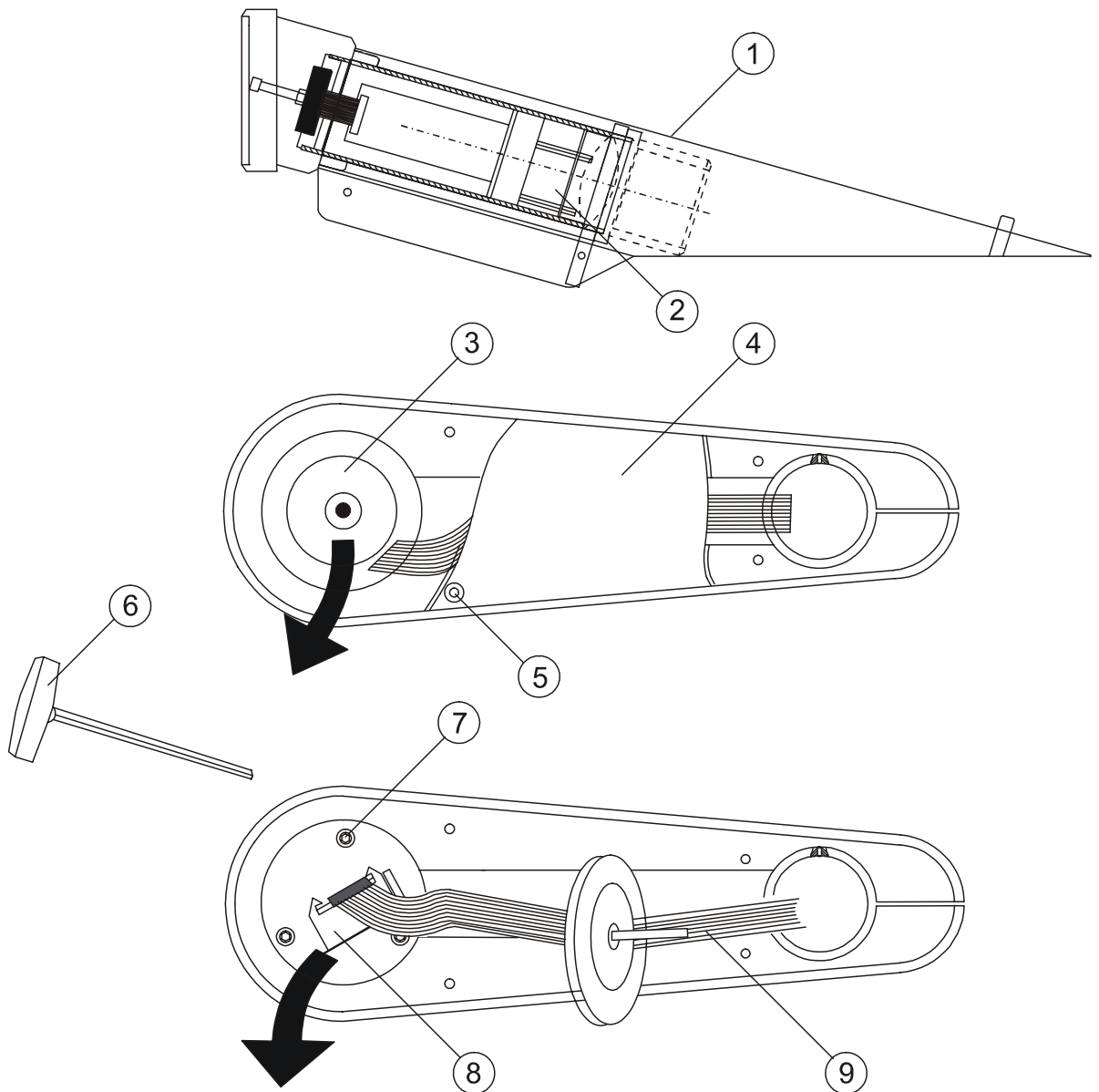

0110-187

**Figure 33 Removing the Optical Units**

The following numbers are related to Figure 33 above:

- 1 = Hood tube
- 2 = FDT12B transmitter/FDR12 receiver
- 3 = Round flange
- 4 = Cover
- 5 = 4 screws (M6 x 16 DIN7991)
- 6 = 5 mm Allen key
- 7 = 3 locking bolts
- 8 = Connector
- 9 = Ribbon cable

To replace the optical unit, do the following:

1. Insert the FDT12B Transmitter/ FDR12 Receiver unit into the hood. Note that the position of the unit is correct, see Figure 34 below.
2. Connect the ribbon cable connector with the optical unit.
3. Tighten the three-hexagon socket locking bolts with a 5-mm, T-handle Allen key.
4. Replace the round flange firmly. Note the ribbon cable path and make sure the cable is run along the path safely.
5. Finally, fasten the outer cover with four screws.
6. Perform visibility calibration.

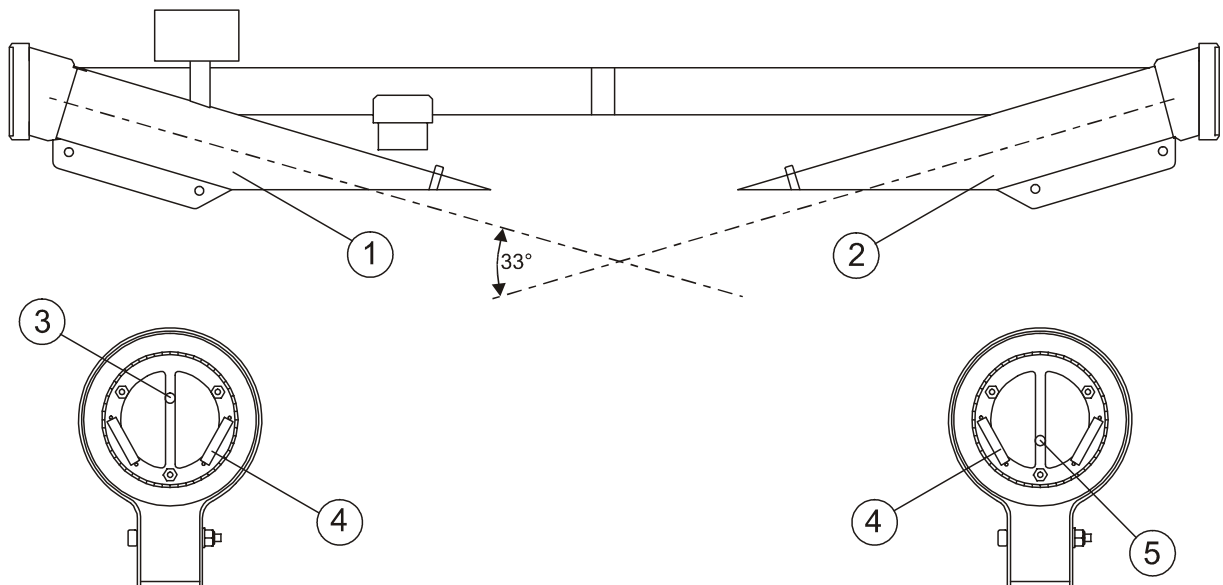

**Figure 34 Replacing the Optical Units**

The following numbers refer to Figure 34 above:

- 1 = FDT12B transmitter
- 2 = FDR12 receiver
- 3 = Photodiode
- 4 = Heating elements
- 5 = LED

## Removing and Replacing the DRD12 Rain Detector

To remove the DRD12, do the following:

1. Remove the two nuts of the assembly clamp. Refer to Figure 35 below. The DRD12 Rain Detector is attached to the crossarm with its cable only.
2. Detach the windshield by loosening the bolt.
3. Remove the cover of the DRD12 unit by loosening the four screws.
4. Loosen the hexagon nut of the cable feedthrough and detach the wires from the screw terminal inside the DRD12 unit. Then pull the DRD12 cable out of the unit.
5. Deliver the entire DRD12 unit to Vaisala.

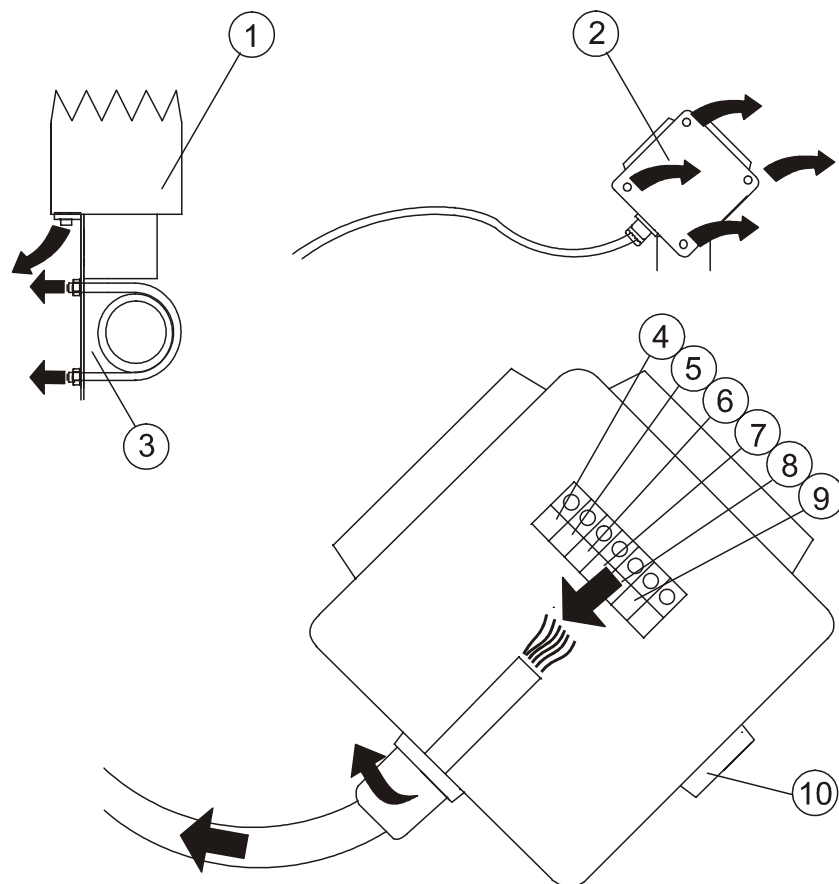

0110-189

**Figure 35** Removing the DRD12 Rain Detector

The following numbers refer to Figure 35 on page 129:

- 1 = Wind shield
- 2 = Two RainCap™ elements
- 3 = Assembly clamp
- 4 = White
- 5 = Red
- 6 = Blue
- 7 = Yellow
- 8 = Green
- 9 = Black
- 10 = Pressure compensation element

To replace the DRD12, do the following:

1. Pull the DRD12 cable through the feedthrough of the DRD12 unit and attach the six wires to the screw terminal as shown in Figure 35 on page 129.
2. Tighten the hexagon nut of the feedthrough.
3. Place the cover on the DRD12 unit and fasten the four screws.
4. Fix the windshield with the bolt. Place the assembly clamp and fasten the DRD12 to the crossarm by tightening the two nuts.

## **Calibrating FD12P Weather Sensor after Unit Replacement**

The hardware of FD12P electronics unit has been checked and tuned at the factory. All adjustments specific to a complete sensor are made in the software. The sensor stores the calibration factors and several internal monitoring values in the EEPROM memory on the processor board. The parameters in question are listed in Table 24, Table 25, and Table 26 on page 131.

**Table 24 Parameters for Optical Measurement**

Parameter	Type of Parameter	Command to Change the Parameter
Transfer function scaling factor	Calibration constant	CAL (FCAL)
Offset reference value	Internal monitoring	CONF
Transmitter backscatter reference value	Internal monitoring	CLEAN
Receiver backscatter reference value	Internal monitoring	CLEAN

**Table 25 Parameters for DRD12 Precipitation Detector**

Parameter	Type of Parameter	Command to Change the Parameter
Dry state offset value	Calibration constant	DRY
Output scaling factor	Calibration constant	WET

**Table 26 Parameters for DTS14 Temperature Sensor**

Parameter	Type of Parameter	Command to Change the Parameter
Offset value	Calibration constant	TCAL TS
(Scaling factor	Calibration constant	TCAL TS)

If any electronics units are replaced, some (or all) of the parameters may need to be updated. Table 27 below describes the necessary operations for each unit.

**Table 27 Updating Parameters**

Unit	Necessary Operations	Commands
FDT12B Transmitter Unit	Update optical calibration, offset reference value and backscatter reference.	CAL (FCAL) CONF CLEAN
FDR12 Receiver Unit	Update optical calibration, offset reference value and backscatter reference.	CAL (FCAL) CONF CLEAN
DRD12 Precipitation Detector	Update dry offset value (and scaling coefficient.) Note! Scaling coefficient can be left unchanged without practically any harmful effects.	DRY (WET)
DTS14 Temperature Sensor	Update offset value.	TCAL TS
DRI21 Sensor Interface	Update temperature offset.	TCAL TS
FDP12 Processor Board	All of the above (including WET).	

The parameters controlling the operation mode (automatic or polling), message type, and weather type decision thresholds are also stored in the EEPROM. If the processor board is replaced, these parameters should also be checked and updated. The parameters and commands are listed in Table 28 on page 132.

**Table 28 Parameters and Commands**

<b>Parameter</b>	<b>Checking Command</b>	<b>Changing Command</b>
Sensor ID	PAR	CONF
Message type		
Sending mode	PAR	AMES
Weather parameters	WPAR	WSET

## CHAPTER 7

# TROUBLESHOOTING

## Warnings

**WARNING** The equipment contains dangerous voltage of 230 VAC.

**CAUTION** Servicing the equipment must be performed by qualified personnel.

## Troubleshooting Examples

### Message Indicating Warning or Alarm

1. Open the command mode and check the status information with the STA command or poll Message 3 for the same information.
2. See section STA Command on page 85 for descriptions of the status message errors and warnings.
3. Check the monitoring values against the internal monitoring limits.

## Message Missing

1. Check that your terminal has the correct settings. The FD12P default is 300 bit 7E1.

If the settings are not correct, you can

- Change the baud rate, for example, to 300 baud.
  - Check that you have seven data bits, even parity, one stop bit.
2. Try the OPEN command (see section Entering/Exiting the Command Mode on page 61) and try other commands to see if the FD12P is already in the command mode.
  3. Go to the site with the maintenance PC (terminal), terminal cable, tools, and the calibrator set.
  4. Check that the FD12P powered by opening the FD12P electronics enclosure cover to check if the LEDs are blinking.
  5. If no LED is on, do the following:
    - Check that the main switch is on (FDW13).
    - Check the mains fuse (250 mA) and replace it if needed.

<b>WARNING</b>	The main fuse contains dangerous voltages of 230 VAC.
----------------	---

- Check the low voltage fuse on the regulator board and replace it if needed.
  - Check that all the connectors are properly inserted.
  - Check the power cable and connections.
  - Measure the mains voltage.
6. If the green LED is blinking (once per second for correct operation), do the following:
    - Connect a maintenance terminal to the RS-port.
    - Check steps 1 and 2.
    - Try resetting by turning off power or disconnecting the fuse on the regulator board for a few seconds.
  7. When only the red LED is lit or blinking, do the following:
    - Try resetting as above.
    - If the state continues, it is probably caused by either the program memory or CPU fault.

## Visibility Value is Missing

1. The FD12P control electronics is probably working. Check the following:
  - Check the status information with the STA command (see section STA Command on page 85). If there are active hardware alarms, visibility values are removed from data message.
  - Check especially P15, M15, BACKSCATTER and LED1. See section Values for Internal Monitoring on page 137 for the limits.
2. Go to the FD12P site and do the following:
  - Check the cable connector at the control board.
  - Check the receiver and transmitter units. Follow the instructions in section Removing and Replacing on page 126 when removing the units.
  - Check that the ribbon cable connector is properly connected.
  - Pull out the circuit boards, first of the receiver (loosen the bolts) and then the transmitter.
  - Visually inspect the condition of the electronics.

## Visibility Value is Continuously Too Good

This can be caused by several reasons, some of which are listed below. Most probably the light path from the transmitter to the receiver is disturbed.

- a. The lenses may be excessively contaminated, which produces a warning. Clean the lenses (see section Cleaning on page 118).
- b. One of the hoods has been filled with snow, leaves, or other things, for which a warning is generated. Clean the hoods.
- c. There is condensation on the lens surfaces, which is a sign of heating failure.
- d. An electrical fault has occurred in the transmitter or receiver. See items in section Visibility Value is Missing on page 135.

## Visibility is Constantly Too Low

Usually there is something disturbing in the sample volume. Check the following:

1. Check the condition of the hoods. If the hoods are slightly twisted, try to align them as well as possible.
2. Try to find a better direction for the receiver/transmitter optics. See section Location and Orientation on page 30.
3. There may be an electrical fault. See items in section Visibility Value is Missing on page 135.

## FDP12 Reports Precipitation When There Is None

When temperatures are below 0 °C, only the optical measurement is used in precipitation detection. When the temperature is above 0 °C, the DRD12 detection is used in cross-checking the optical detection and false detection can only be caused by problems in both measurements.

1. Check that there are no flashing lights close to the FD12P. Flashing lights may cause the FD12P to detect peaks in the optical signal.
2. Check that there are no foreign objects in the sample volume. Tree branches or any other moving objects in the sample volume may cause sudden changes in the scatter signal.
3. If a false detection has occurred in a temperature above 0 °C, the DRD12 does not function correctly. Do the following:
  - Clean the DRD12 sensing surfaces thoroughly.
  - Check the DRD12 operation.

## FD12P Reports Frozen Precipitation during Rain

The ratio of optical intensity measurement to DRD12 measurement is too high. Do the following:

1. Check the optical calibration and DRD12 operation.
2. Check the TS temperature sensor operation.

3. If everything else seems to be functioning correctly, change the parameter settings as follows:
  - If possible, check the accumulated water sum against a reference rain gauge. This will indicate how close *Rain intensity scale* is to the optimal value. Decrease the scaling factor if the FD12P rain amount is too high.
  - Otherwise, increase *DRD scale*.

## Have Jumper Settings Been Changed?

If you have reason to believe that the original jumper settings have been changed, see Appendix B on page 147.

## Values for Internal Monitoring

The typical values are according to factory testing and are allowed to be changed within the given minimum/maximum limits. For example, the LEDI value is dependent on ambient temperature of more than +25 °C and aging of the IR-LED.

The fault limits give hints for troubleshooting.

The values for internal monitoring are listed in Table 29 on page 138.

**Table 29 Values for Internal Monitoring**

Message	Typical	Min/ Max	Fault	Description	Action
DUTY Indicates the pulse ratio in lock-in amplifier circuit.	1.6 V	+1 V/ +2.5 V	<1 V >2.5 V  0.0 V or 5 V	Synchronizing signal from the receiver to the transmitter is missing.  The oscillator of the transmitter is not working.	1. Check condition and contact of -flat cable -connectors 2. Change the receiver.  1. Change the transmitter.
AMBL Ambient light.	-0 V	-9 V/ +3 V	>3 V  <-9 V	Preamplifier is not working.  The sun is shining directly or from reflecting surface (water, window, etc.) to the receiver.	1. Change the receiver.  2. Check orientation of FD12P.
VH Lens heater.	0.8 V	+0.6 V/ +1.2 V	<0.2 V	No heating current is flowing.	1. Check that the jumper X13 (CPU) is 1-2 or 2-3.
OFFSET The lowest frequency for measurement signal.	130 Hz	120 Hz/ 150 Hz	<120 Hz >150 Hz		1. Check other parts of the STA message. 2. Change the receiver.
REC. BACKSCATTER Measurement signal from the receiver contamination control circuit. Clean value.			Rec. backscatter CHANGE (Instant backscatter - clean back scatter > alarm limit 'BACK- SCATTER HIGH'.	Alarm that there is obstruction in the light path. Rising value can be caused by - contamination of receiver optics - snow inside the receiver hood - spider net in front of the hood, etc. Check also the contamination limits.	Clean outside of optical surfaces and remove possible disturbances from the optical path.
			Rec. backscatter CHANGE (Instant backscatter - clean back scatter > warning limit 'BACK- SCATTER INCREASED'.	Warning that there is small obstruction in the light path or increased contamination on the lens surface. Indication that optical surface should be cleaned in the near future.	Clean the optical surfaces in the near future. The measurement values are still reliable.

Message	Typical	Min/ Max	Fault	Description	Action
TR. BACKSCATTER Control signal for the transmitter contamination. Clean value.			<-15 V >14 V 'TRANSMITTER ERROR'	Decreasing value can be caused as above (REC. BACKSCATTER)	
LEDI Actuating signal for the LED control (transmitter).	0 V ... 6.5 V	-8 V/ +7 V	>+7 V <-8 V	Changes in the voltage can be caused by -aging of the LED (voltage decreases) -rising temperature (voltage decreases) -changes depending on ambient temperature (temperature control is possibly not working). If the voltage is between -3 V ... -8 V, the control loop is operating properly but the IR LED may change for the worse in the near future.	Change the transmitter.
TE Ambient temperature.	-40°C ... +50°C		<-60°C  >+50°C at any rate	Sensor disconnected.  Sensor or cable is short circuit.	Check X14 connection on CPU board.  Check temperature sensor cable on CPU board.
SIGNAL Frequency of the transmission signal between transducer and CPU (Hz) is inversely proportional to visibility.  Freq.    Corr. Visibility 1 Hz    4.5 km 10 Hz   800 km 100 Hz   150 km	0.00 Hz ... 10000.00 Hz			Connect jumper X11 1-2 on CPU board for sound. (Speaker not normally installed on CPU board. Audible sound repeats the frequency signal. Move your hand in the sampling volume, and you can check the operation of FD12P. Sound changes in range 130 ... 10000 Hz depending on the object movements in the sample volume.	If no sound or no change, check other information of the STA message.
VBB absolute $V_{BB}=V_b*2 - 1.2$ V  when $V_b=12$ V	22.8 V	16 V / 25 V	<16 >25  <21 V >24 V	Power input for the electronics is on the CPU board, connector X17, pin 4, pin 6: GND. Vb voltage value is +8.6 ... +13 V.	

Message	Typical	Min/Max	Fault	Description	Action
P15 Positive voltages of the DC / DC converter for the transmitter/receiver .	+15.0 V	+14 V/ +16 V	<+14.0 V >+16.0 V	DC/DC converter is overloaded or working wrong.	1. Check flat cable between transmitter/receiver. 2. Change the transmitter. 3. Change the receiver.
M15 Negative voltages of the DC/DC converter for the transmitter/receiver	-15.0 V	-16 V/ -14 V	>-14.0 V <-16.0 V	DC/DC converter is overloaded or working wrong.	1. Check flat cable between transmitter/receiver. 2. Change the transmitter. 3. Change the receiver.
BGDN Ground potential for the transducer, i.e., voltage loss in transducer cable.	~0 V	-0.5 V/ +1 V	<-0.5 V >+1 V		Check transducer cable.

## Getting Help

For technical support or comments on the manual, contact the Vaisala technical support:

E-mail            [helpdesk@vaisala.com](mailto:helpdesk@vaisala.com)

Telephone        +358 9 8949 2789

Fax                +358 9 8949 2790

## Return Instructions

If the product needs repair, please follow the instructions below to speed up the process and avoid extra costs.

1. Read the warranty information.
2. Write a Problem Report with the name and contact information of a technically competent person who can provide further information on the problem.

3. On the Problem Report, please explain:
  - What failed (what worked/did not work)?
  - Where did it fail (location and environment)?
  - When did it fail (date, immediately/after a while / periodically/randomly)?
  - How many failed (only one defect/other same or similar defects/several failures in one unit)?
  - What was connected to the product and to which connectors?
  - Input power source type, voltage and list of other items (lighting, heaters, motors etc.) that were connected to the same power output.
  - What was done when the failure was noticed?
4. Include a detailed return address with your preferred shipping method on the Problem Report.
5. Pack the faulty product using an ESD protection bag of good quality with proper cushioning material in a strong box of adequate size. Please include the Problem Report in the same box.
6. Send the box to:  
Vaisala Oyj  
SWD Service  
Vanha Nurmijärventie 21  
FIN-01670 Vantaa  
Finland

This page intentionally left blank.

## APPENDIX A

**NWS AND WMO CODES USED IN  
FD12P****The NWS Codes****Table 30 Internal Weather Types, NWS Code**

<b>Weather Type</b>	<b>Code</b>
No precipitation	C
Precipitation	P
Drizzle	L
Rain	R
Snow	S
Ice pellets	IP
Sleet	IP
Hail	A
Ice crystals	IC
Snow grains	SG
Snow pellets	SP
Freezing drizzle	ZL
Freezing rain	ZR

The NWS codes are used with intensity indicator '+' for heavy, '-' for light, and none (space) for moderate. For example, 'R+' means heavy rain.

**Table 31 WMO SYNOP Codes (4680, W<sub>a</sub>W<sub>a</sub>)**

<b>Code</b>	<b>Weather type</b>
00	Clear.
04	Haze or smoke, or dust in suspension in the air, visibility equal to or greater than 1 km.
05	Haze or smoke, or dust in suspension in the air, visibility less than 1 km.
10	Mist.

Code figures 20 to 25 are used, if precipitation or fog was observed during the preceding hour but not at the time of observation.

**Table 32 WMO SYNOP Codes (4680,  $W_aW_a$ )**

Code	Weather type
20	Fog
21	PRECIPITATION
22	Drizzle (not freezing) or snow grains
23	Rain (not freezing)
24	Snow
25	Freezing rain or freezing drizzle

The following code figures are used if precipitation or fog is observed at the time of observation.

**Table 33 WMO SYNOP Codes (4680,  $W_aW_a$ )**

Code	Weather type
30	FOG
31	Fog or ice fog, in patches.
32	Fog or ice fog, has become thinner during the past hour.
33	Fog or ice fog, not applicable change during the past hour.
34	Fog or ice fog, has begun or become thicker during the past hour.
40	PRECIPITATION
41	Precipitation, slight or moderate
42	Precipitation, heavy
50	DRIZZLE
51	Drizzle, not freezing, slight
52	Drizzle, not freezing, moderate
53	Drizzle, not freezing, heavy
54	Drizzle, freezing, light
55	Drizzle, freezing, moderate
56	Drizzle, freezing, heavy
60	RAIN
61	Rain, light
62	Rain, moderate
63	Rain, heavy
64	Rain, freezing, light
65	Rain, freezing, moderate
66	Rain, freezing, heavy
67	Rain, (or drizzle) and snow, light
68	Rain, (or drizzle) and snow, moderate or heavy
70	SNOW
71	Snow, light
72	Snow, moderate
73	Snow, heavy
74	Ice pellets, light
75	Ice pellets, moderate
76	ice pellets, heavy
77	Snow grains (from WMO 4677)
78	Ice crystals (from WMO 4677)

Code	Weather type
80	SHOWERS OR INTERMITTENT PRECIPITATION
81	Rain showers, light
82	Rain showers, moderate
83	Rain showers, heavy
84	Rain showers, violent (>32 mm/h)
85	Snow showers, light
86	Snow showers, moderate
87	Snow showers, heavy
89	Showers of hail, with or without rain or rain and snow mixed, not associated with thunder (from WMO 4677)

**Table 34 WMO Code Table 4678. Codes Used by FD12P**

Qualifier		Weather Phenomena	
Intensity 1	Descriptor 2	Precipitation 3	Obscuration 4
-Light	BC Patches	DZ Drizzle	BR Mist
Moderate (no qualifier)	SH Shower(s)	RA Rain	FG Fog
+Heavy	FZ Freezing	SN Snow	DU Widespread dust
		SG Snow Grains	HZ Haze
		IC Ice Crystals	
		PL Ice Pellets	
		GR Hail	

This page intentionally left blank.

## APPENDIX B

# JUMPER SETTINGS AND INTERNAL WIRING

See Figure 36 on page 148.



## CPU Board

**Table 35 CPU Board Jumpers**

Jumpers	Description
X2	Memory selection 1-2 for 27256, 2-3 for 27512
X5	Watchdog ON 1-2, reset 2-3
X7	PICOBUS™ powering
X11	Not in use
X13	Lens heating 1-2, on 2-3 with on/off driver

**Table 36 CPU Board Connectors**

Connectors	Description
X3	PICOBUS (for DRI21 interface board)
X14	Temperature sensor (FDE12)
X15	To transducer crossarm (transmitter/receiver)
X16	<i>Not in use!</i>
X17	Supply voltage, pin 4: 10-12 VDC, pin 6: GND
X18	RS-232 connector pin 1: GND, pin 2: RxD, pin 3: TxD (for remote and maintenance use)
X19	RS-232 control signals (for DMX21 or other options)
X20	Analog current output (sinking type)
X21	RS-485 (alternative use to RS-232)

## DC-Regulator

**Table 37 DC-regulator Connectors**

Connectors	Description
X1	Pin 1, 3: output for hood heaters, (pin 3: alternative status relay output)
X2	Pin 1, 2: power input 18 ... 26 V (electronics), pin 3, 4: power input 20 ... 24 VAC/4A for hood heaters, (pin 4: alternative status relay input)
X3	DC output connector pin 6: GND, pin 4: +11..12 V

## DRI21 Interface Board

**Table 38 DRI21 Interface Board Jumpers**

Jumpers	Description
X3	PICOBUS address selection

**Table 39 DRI21 Interface Board Connectors**

Connectors	Description
X1	sensor interface
X2	auxiliary board connector
X4	PICOBUS connector

**Table 40 Electronics Enclosure/Transducer Cable Signals**

Description	Signal name	Enclosure			Crossarm	
		Color	FDP12	Mil plug	FDT/FD R cable	DRD12 cable
Ground	GND	BRN	X15/1	A	1/BRN	-
Supply voltage	+Vb	RED	X15/2	B	2/RED	-
Lens heating	Leh	ORN	X15/3	C	3/ORN	-
Ground	GND	YEL	X15/4	D	4/YEL	-
Frequency non-inverting	Frq5	GRN	X15/5	E	5/GRN	-
Frequency inverting	Frq6	BLU	X15/6	F	6/BLU	-
Channel bit 2/offset mode	Cb2	VIO	X15/7	G	7/VIO	-
Analog mux. channel	Mux	GRY	X15/8	H	8/GRY	-
Channel bit 1/backsc. led	Cb1	WHT	X15/9	J	9/WHT	-
Channel bit 0/led off	Cb0	BLK	X15/10	K	10/BLK	-
Supply voltage	+Vb	BRN	-	B	11/BRN	-
Timing reset	Res	RED	-	-	12/RED	-
Ambient light	Ali	ORN	-	-	13/ORN	-
Analog voltage	-15 V	YEL	-	-	14/YEL	-
Analog voltage	+15 V	GRN	-	-	15/GRN	-
Analog ground/spare	AGND	BLU	-	-	16/BLU	-
DRD12 supply voltage	+12 V	YEL/GRN	X15/2	R	-	RED
DRD12 heater GND	GND	-	-	A	-	WHT
Description	Signal name	Enclosure			Crossarm	
		Color	DRI12	Mil plug	FDT/FD R cable	DRD12 cable
Rain on/off	R. ON/OFF	WHT/GRN	X1/10	S	-	BLU
Heater off	H. OFF	ORN/GRN	X1/13	T	-	GRN
Analog out	A. OUT	GRN/RED	X1/22	U	-	YEL
Analog GND	A.GND	ORN/RED	X1/17	V	-	BLK
Description	Signal name	Enclosure			Crossarm	
		Color	FDS13	Mil plug	FDT/FD R cable	DRD12 cable
Heater AC supply (Tx)	HCout	L.RED	X1/1	L	-	BRN
Heater AC supply (Tx)	HRout	L.BLU	X1/3	M	-	BLU
Heater AC supply (Rx)	HRout	YEL/BLU	X1/3	N	-	BLU
Heater AC supply (Rx)	HCout	WHT/BLU	X1/1	P	-	BRN

# APPENDIX C

## TRANSMITTER AND RECEIVER TEST POINTS

There are some test points (TP) on the FD12P circuit boards for testing. They are as follows:

**Table 41 Transmitter Test Points**

Test Point	Description
TP1	Reference voltage +2.5 V, $\pm 1\%$
TP4	Feedback signal
TP5	Control voltage for LED driver, >-8 V <+7 V
X1/1	+15 V
X1/2	-15 V
X1/3	+5 V
X1/4	GND

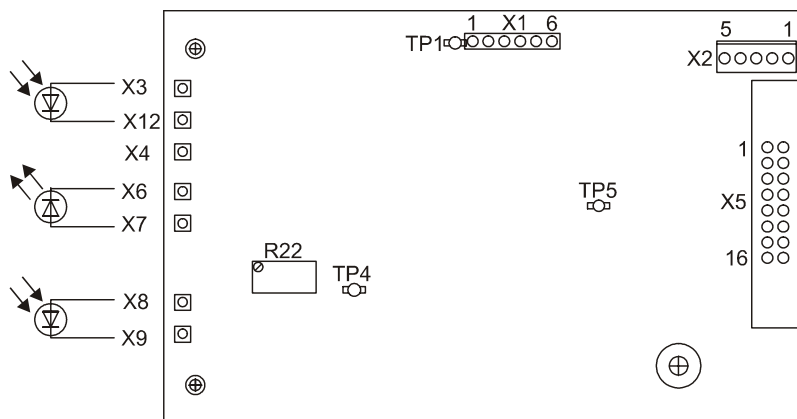

9611-005

**Figure 37 Test Points, Transmitter**

**Table 42 Receiver Test Points**

Test Points	Description
TP1	Synchronizing pulse for factory tests
TP2	Reference voltage -2.5 V, $\pm 1$ %
TP3	+5 V
TP4	Measurement signal after high-pass filter
TP5	P15: +15 V, $\pm 1$ V
TP6	M15: -15 V, $\pm 1$ V
TP7	GND
TP8	Measurement signal after 2-stage amplifier (AC)
TP9	Measurement signal 0 ... -10 V before V/F converter

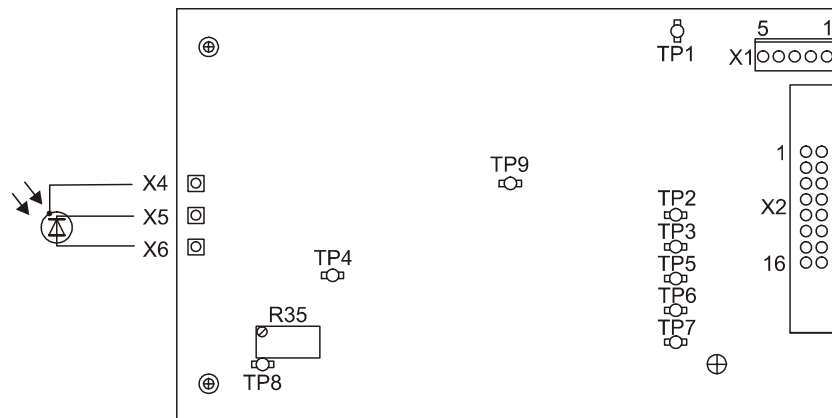

9611-006

**Figure 38 Test Points, Receiver**

**CPU**  
 TP1 GND  
 TP2 GND

# INDEX

## A

Additional Measurements	99
Algorithm	105
AMES	71
Analog output commands	
ACAL	92
Analog Output Commands	91
Analog Transmission	55
Applications	113
Assembling the FD12P	40
Automatic Message Sending	62

## B

Basic Wiring	43
BAUD	84
BLSC	48, 84
Built-in Tests	114

## C

Cable Selection	35
Cabling Principle	44
CAL	87, 123
Calibrating the DTS14B Temperature Sensor	124
Calibration	119
Capabilities and Limitations	26
Capacitive precipitation sensing	21, 100
CHEC	89, 120
CLEAN	88, 118
Cleaning DRD12 Rain Detector	118
Cleaning Lenses and Hoods	118
CLOSE	62
CLRS	78
Communication Cable EMC-shielding	46
Communication Options	50
CONF	80
Connecting Cables	43
Connecting Internal Grounding	43
Connecting the Maintenance Terminal	55
Constructing the Foundation	37

Contamination Monitoring	116
crossarm	17, 18, 19, 20, 22, 30, 34, 40, 42, 87, 99, 102, 110, 111, 119, 120, 123, 126, 129, 130, 149

## D

DAC command	92
DATE	93
Detecting Precipitation	106
DRD12 Rain Detector	100
DRD12 Signal Processing	104
DRI21 Interface Board	99
DRY	89
DTS14 Temperature Sensor	18, 124, 131

## E

Entering/Exiting the Command Mode	61
Equipment Grounding	32
Equipment Nomenclature	23
errors	31, 86, 123, 133

## F

FD12P Command Set	70
FDP12 Control Unit	101
FDR12 Receiver Unit	98
FDT12B Transmitter	96
FDW13 Mains Power Supply	45
forward scatter measurement	21, 95
FREQ	89, 124

## G

Grounding and Lightning Protection	32
Grounding for Testing Purposes	34
Grounding Remote Units and Communication Cable	34

## H

hardware errors	56
Hardware Monitoring	115

Hardware Structure	17	Precipitation Accumulation	107
HELP	70	Precipitation Intensity	106
<b>I</b>		Precipitation Types	108
Initial Settings	56	PRW	77
Installation Procedures	37	<b>R</b>	
Internal Grounding	34	Related Manuals	12
Internal Monitoring	114	Removing and Replacing	126
<b>L</b>		Removing and Replacing the DRD12 Rain	
line voltage setting switch	45	Detector	129
Location and Orientation	30	RESET	94
<b>M</b>		<b>S</b>	
Mains Power Supply FDW13	20	Safety	12
Maintenance	117	Safety summary	13
Markings Used in This Manual	61	Serial Communications Settings	50
Measurement Signal Processing	103	Serial Multipoint Transmission RS-485	51
Memory Tests	115	Serial Transmission RS-232	50
MES	63, 71	Signal Monitoring	115
Message 0	64	Specifications	24
Message 1	64	STA	85, 133, 135
Message 2	65	Startup Testing	56
Message 3	65	status message	22, 63, 65, 83, 85, 114, 115,
Message 4	66	116, 133	
Message 7	68	SYNOP	17, 22, 113, 143, 144
Message Types	63	<b>T</b>	
Messages 5 and 6	66	TCAL	87, 124
MIL-connector	34, 40, 43	The FDS12 DC Voltage Regulator	20
Modem DMX21	52	TIME	93
MOR	21, 26, 30, 48, 95, 105, 106	<b>U</b>	
Mounting to an Existing Surface	38	Unloading and Unpacking	36
Mounting When Casting the Pad	38	User Commands in Normal Operation	59
<b>N</b>		Using FD12P	22
NWS	113	<b>V</b>	
<b>O</b>		visibility algorithm	105
ON/OFF switch	20, 45	<b>W</b>	
OPEN	61	warnings	13, 25, 56, 114, 116, 118, 119, 133
Operating Principle	21	Weather Classes	112
Optical Measurement	96	Weather Code Selection	113
Optical Signal Processing	103	WET	89
Organizing Installation	29	WHIS	78
<b>P</b>		WMO codes	59, 111, 113
PAR	79	WPAR	73
Polling	69	WSET	58, 73
power cable	13, 14, 35, 43, 44, 46, 134		