

HMM210 Series Humidity Modules for Environmental Chambers

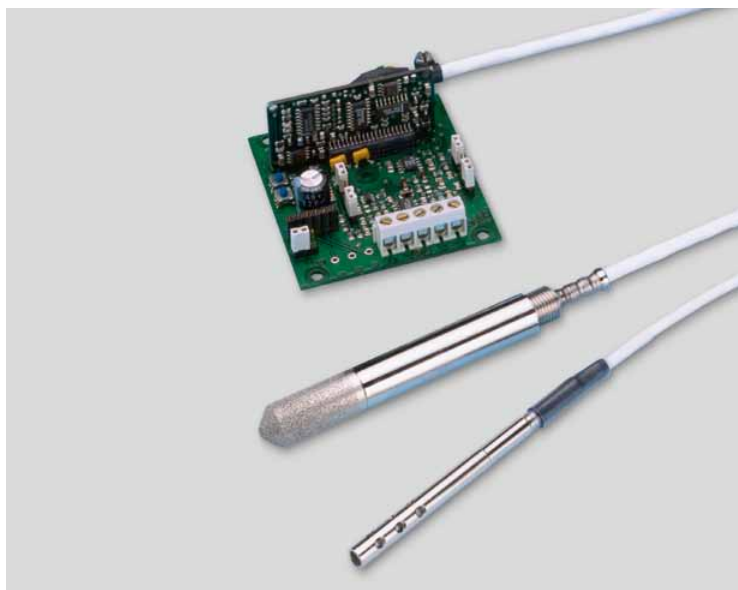

Vaisala HUMICAP® Humidity and Temperature Module Series HMM210 provide fast real-time measurement in a wide temperature range. The modules are especially suitable for demanding OEM applications, e.g. environmental chambers and incubators.

Features/Benefits

- Three probe configurations:
- Relative humidity (RH) plus temperature (T) probe.
- Dewpoint probe with probe heating. By heating the whole probe a few degrees above ambient condensation is avoided.
- Dewpoint probe described above, together with a temperature probe for obtaining relative humidity and temperature outputs.
- Three module configurations
- Different probe and cable lengths
- Chemical purge option maintains high measurement performance in demanding chemical conditions.
- Calibration certificate included

The Vaisala HUMICAP® Humidity and Temperature Module Series HMM210 are designed for OEM type applications needing humidity or dewpoint measurement in demanding environments, e.g. in environmental chambers, growth chambers and incubators.

Demanding Applications

The HMM210 modules are optimized for harsh environments with both high humidities and a wide temperature range. The humidity measurement is fully temperature compensated. In addition, the modules remain accurate and reliable under extreme conditions where a combination of high humidity and rapidly changing temperature can result in condensation on the sensor head.

The modules are highly versatile and flexible. They provide either

relative humidity and temperature or dewpoint measurement with various configurations. All modules have microprocessor based electronics and are equipped with analog or digital outputs.

Unique Warmed Probe

The warmed probe and composite sensor, available on the dewpoint probe configuration, is warmed to always remain a few degrees higher than ambient. Advantages of this patented technique include:

- No condensation problems on the probe, as the temperature of the probe always remains higher than the ambient.
- Fast response time, especially in rapidly changing temperatures.
- Improved stability and accuracy in high humidities.

Vaisala HUMICAP® Sensor and Chemical Purge Option

The HMM210 modules use Vaisala HUMICAP®180R sensors for best possible stability. The sensor is insensitive to dust and to most chemicals. In conditions of extraordinary high levels of chemicals and cleaning agents, chemical purge is available as an option. With chemical purge, contaminants are evaporated from the sensor and performance is returned to normal.

Technical Data

Relative Humidity

Measurement range	0 ... 100 %RH
Accuracy (including non-linearity, hysteresis and repeatability)	± 2 %RH (0 ... 90 %RH) ± 3 %RH (90 ... 100 %RH)
Response time (90 % at +20 °C/+68 °F) in still air (with sintered filter)	60 s
Typical temperature dependence of electronics	0.02 %RH/°C (0.02 %RH/°F)
Humidity sensor	HUMICAP®180R

Temperature

Measurement range	-70 ... +180 °C (-94 ... +356 °F)
Typical accuracy of electronics at +20 °C	± 0.1 °C (± 0.18 °F)
Typical temperature dependence of electronics	0.0025 °C/°C (0.0025 °F/°F)
Temperature sensor in RH+T probe:	
HMM211 and HMM213	Pt 100 RTD IEC 751 1/3 Class B
HMM212	Pt 1000 RTD IEC 751 1/3 Class B
Additional temperature probe	Pt 100 RTD IEC 751 1/4 Class B

Outputs

Two analog outputs selectable	
HMM211	0 ... 1 V, 0 ... 5 V, 0 ... 10 V 0 ... 20 mA
HMM212	4 ... 20mA (loop powered)
Digital output	
HMM213	RS232

Dimensions

Dimensions in mm (inches)

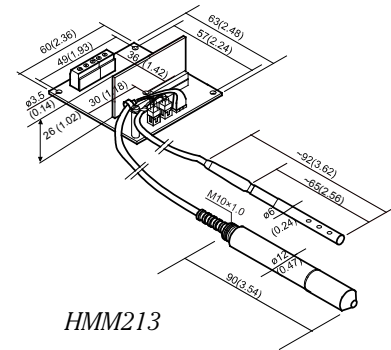
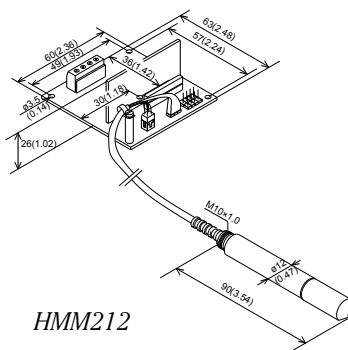
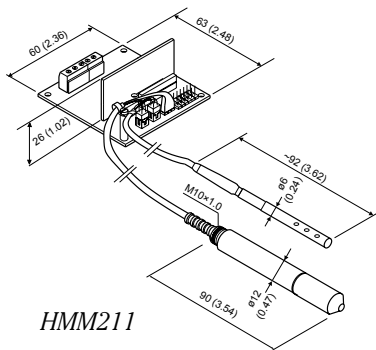

General

Operating temperature range	
Probe	-70 ... +180 °C (-94 ... +356 °F)
Electronics	-5 ... +55 °C (+23 ... +131 °F)
Storage temperature range (Electronics)	-40 ... +70 °C (-40 ... +158 °F)
Sensor protection (standard)	stainless steel sintered filter
Connections	screw terminals for 0.5 ... 1.5 mm ² wires

Power Supply

Operating voltage	10 ... 35 VDC
In modules with analog outputs the supply range depends to a certain extent on the selected output range.	
Current consumption without sensor head warming or re-gaining option	
HMM211 & HMM213	12 mA at 35 VDC

Configuration Options

	Compatible with modules:		
PROBES	HMM211	HMM212	HMM213
RH+T	yes	yes	yes
Dewpoint (heated composite sensor)	yes		yes
Temperature	yes		yes
CABLE LENGTHS			
RH+T and Dewpoint probes			65, 150 and 300 cm
Temperature probe			150 and 300 cm
CHEMICAL PURGE	Automatically takes place at power-up		
HUMICAP® is a registered trademark of Vaisala.			



For more information, visit www.vaisala.com or contact us at sales@vaisala.com

Ref. B210901EN-B ©Vaisala 2011
This material is subject to copyright protection, with all copyrights retained by Vaisala and its individual partners. All rights reserved. Any logos and/or product names are trademarks of Vaisala or its individual partners. The reproduction, transfer, distribution or storage of information contained in this brochure in any form without the prior written consent of Vaisala is strictly prohibited. All specifications — technical included — are subject to change without notice.

